

IMS



# Administration Guide: Transaction Manager

*Version 9*



IMS



# Administration Guide: Transaction Manager

*Version 9*

**Note**

Before using this information and the product it supports, be sure to read the general information under “Notices” on page 601.

**Third Edition (December 2006)**

This edition replaces or makes obsolete the previous edition, SC18-7808-01. The technical changes for this version are summarized under “Summary of Changes” on page xvii.

© Copyright International Business Machines Corporation 1974, 2006. All rights reserved.

US Government Users Restricted Rights – Use, duplication or disclosure restricted by GSA ADP Schedule Contract with IBM Corp.

---

# Contents

**Figures . . . . . vii**

**Tables . . . . . ix**

**About This Book. . . . . xi**

Prerequisite Knowledge . . . . . xi  
IBM Product Names Used in This Information . . . . . xii  
How to Read Syntax Diagrams . . . . . xiii  
How to Send Your Comments . . . . . xv

**Summary of Changes. . . . . xvii**

Changes to the Current Edition of This Book for  
IMS Version 9 . . . . . xvii  
Changes to This Book for IMS Version 9 . . . . . xvii  
Library Changes for IMS Version 9 . . . . . xvii

---

## **Part 1. IMS Transaction Manager Network . . . . . 1**

### **Chapter 1. IMS Transaction Manager Network Overview . . . . . 3**

IMS TM Network Overview . . . . . 3  
IMS Transaction Manager Services . . . . . 7  
The Data Communication Control (DCCTL)  
Environment . . . . . 10  
Operating an IMS Network . . . . . 10  
The Shared-Queues Environment . . . . . 12  
Balancing Sessions With Generic Resources . . . . . 16  
IMSplex Terminal Management . . . . . 17  
Fast Path Expedited Message Handler . . . . . 19

### **Chapter 2. Planning the Network . . . . . 23**

Planning for Network Administration . . . . . 23  
Documenting Network and Terminal Requirements . . . . . 24  
IMS Terminal Network . . . . . 24  
Designing Logical Terminal Networks . . . . . 32  
Resource Modes and States . . . . . 36  
Planning for Security . . . . . 44  
Planning for Fast Path Terminals . . . . . 47  
Planning for the Extended Recovery Facility (XRF) . . . . . 49  
Planning for Rapid Network Reconnect (RNR) . . . . . 54

### **Chapter 3. Defining the Network. . . . . 59**

Preparing for the Operational Network . . . . . 59  
Coordinating IMS Definition and Network  
Definition . . . . . 60  
Network Operation . . . . . 65  
IMS Transaction Types and Transaction States . . . . . 66  
Restarting the Network after Remote Takeover . . . . . 68  
VTAM Definition for Transport Manager . . . . . 69  
Defining VTAM for Rapid Network Reconnect  
(RNR) . . . . . 70

## **Chapter 4. Editing and Formatting Messages . . . . . 73**

Message Format Service . . . . . 73  
Creating MFS Formats with SDF II . . . . . 81  
Basic Edit . . . . . 83  
IMS Editing for Intersystem Communication (ISC) . . . . . 84  
Transparency Option . . . . . 85  
Unprotected Screen Option . . . . . 86  
Bypassing MFS Editing . . . . . 86  
IMS Sensitivity to Nongraphic Message Data . . . . . 86  
Controlling Output Devices . . . . . 88  
Small Buffer Devices . . . . . 89  
Controlling Output . . . . . 89

---

## **Part 2. Transaction Manager in an IMSplex . . . . . 93**

### **Chapter 5. Planning for Shared Queues 95**

Concepts for Operating in a Shared-Queues  
Environment . . . . . 96  
Planning for Operating in a Shared-Queues  
Environment . . . . . 101

### **Chapter 6. Planning for Generic Resource Groups . . . . . 121**

Requirements for Using Generic Resource Groups . . . . . 121  
Generic Resource Group Restrictions . . . . . 122  
VTAM Generic Resource Affinity . . . . . 122  
Creating a Generic Resource Group . . . . . 123  
Specifying APPC Generic Resource Names . . . . . 123  
Initiating Sessions With IMS in a Generic Resource  
Group . . . . . 123  
XRF and Generic Resources . . . . . 124  
Changing the Logon Procedure . . . . . 124  
Overriding the APPLID Field . . . . . 124  
Determining When Affinities are Terminated . . . . . 125  
Terminating Affinities That Persist . . . . . 125  
Dropping an IMS System from a Generic Resource  
Group . . . . . 125  
Resetting Terminal Status . . . . . 126  
Logging on After IMS Failure with Affinity . . . . . 126  
Controlling Generic Resource Member Selection . . . . . 126  
Ensuring Consistency Across the IMSplex . . . . . 127  
Bypassing Affinity Management During the IMS  
ESTAE Process . . . . . 128

### **Chapter 7. Managing TM Resources in an IMSplex . . . . . 129**

Resource Name Uniqueness . . . . . 129  
Resource Type Consistency . . . . . 130  
Global Callable Services . . . . . 130  
Transaction Manager Resources . . . . . 131  
IMS Activities and RM . . . . . 134

---

**Part 3. Extended Terminal Option 137****Chapter 8. Overview of the Extended Terminal Option . . . . . 139**

Benefits of Using ETO . . . . .	139
ETO Terminology . . . . .	140
ETO Concepts . . . . .	143

**Chapter 9. Administering the Extended Terminal Option . . . . . 147**

Planning for ETO . . . . .	148
Coding ETO Descriptors. . . . .	160
Exit Routines . . . . .	172
Starting ETO . . . . .	172
Logging onto ETO Terminals . . . . .	173
Signing On and Queue LTERM Allocation. . . . .	175
Printers with ETO . . . . .	179
Operator Commands . . . . .	182
System Definition Parameters for ETO . . . . .	182
Assigning Output . . . . .	187
Signing Off . . . . .	189
Logging Off . . . . .	189
Improving Performance by Deleting ETO Control Blocks . . . . .	189
IDC0 Trace Facility . . . . .	190
ETO and LU 6.1 (ISC) Terminals . . . . .	190
ETO and STSN Terminals . . . . .	191
Conversation Mode and Response Mode with ETO	193

---

**Part 4. Multiple Systems Coupling 195****Chapter 10. Overview of Multiple Systems Coupling . . . . . 197**

Multiple Systems Coupling Concepts and Terminology. . . . .	197
The MSC Network and Routing . . . . .	200

**Chapter 11. Administering Multiple Systems Coupling . . . . . 213**

Design Considerations for Multiple Systems . . . . .	213
Planning for Conversational Processing. . . . .	215
System Definition for Multiple Systems Coupling	217
Verifying Transaction Definitions Across Systems	224
Security Considerations for MSC . . . . .	225
Establishing Operating Procedures for Multiple Systems . . . . .	227
IMS Commands That Affect MSC Operation . . . . .	228
Recovery Considerations . . . . .	232
Monitoring and Tuning Multiple Systems . . . . .	233
MSC and IMSplex with Shared Queues: Migration and Coexistence . . . . .	237
TM and MSC Message Routing and Control User Exit Routine. . . . .	247

---

**Part 5. Intersystem Communication . . . . . 251****Chapter 12. Overview of Intersystem Communication . . . . . 253**

What is ISC? . . . . .	253
Comparing ISC to MSC . . . . .	254
IMS Facilities Available to ISC. . . . .	255
Sample System Configurations . . . . .	258
ISC between IMS and CICS. . . . .	259

**Chapter 13. VTAM Facilities Used for ISC . . . . . 263**

VTAM Commands and Indicators . . . . .	264
Using the VTAM Application Program Interface	265
Specifying Logon Modes When Establishing Connection . . . . .	265
Design Considerations for Secondary Logical Units	266

**Chapter 14. IMS Facilities Affected by ISC . . . . . 269**

Editing Messages . . . . .	269
Issuing IMS Commands from an ISC Session. . . . .	270
Effects on Parallel Sessions . . . . .	270
Using IMS Test Mode for ISC Sessions . . . . .	271
IMS Control Block Storage on ISC Parallel Sessions	271
Relationship of ISC and IMS Execution Modes . . . . .	272

**Chapter 15. Designing Communications Using the ISC Protocol . . . . . 277**

Determining Output Protocols. . . . .	277
Accessing Existing Application Programs with ISC	278
Statically Defining an ISC Node to IMS. . . . .	291
Choosing Parameters: System Design Considerations . . . . .	293
System Definition Summary . . . . .	296

**Chapter 16. ISC Protocol Guide and Reference . . . . . 299**

Operating the Network . . . . .	300
Controlling the Session (Session Control Protocols)	301
Resynchronizing Sessions . . . . .	304
Completing Session Initiation . . . . .	312
Running the Session . . . . .	313
Terminating the Session . . . . .	313
Using STSN to Resynchronize Sessions. . . . .	314
STSN Command Format. . . . .	317
Handling IMS Response Mode or Conversational Output Errors . . . . .	319
Normal Conversation Termination Extension with ISC. . . . .	321
Keeping Half Sessions Synchronized . . . . .	321
Data Flow Control Protocol Reference . . . . .	329
Function Management Headers . . . . .	356

**Chapter 17. Using MFS with ISC . . . . . 363**

Activating MFS Input Formatting . . . . .	363
Activating MFS Output Formatting . . . . .	364
MFS Distributed Presentation Management (DPM) Messages. . . . .	364

MFS Page Delete Function . . . . .	365
MFS Online Error Detection . . . . .	365
The ATTACH and SCHEDULER FM Headers under MFS . . . . .	367
Data Descriptor FM Headers . . . . .	368
Controlling Demand-Paged Messages: QMODEL FM Headers . . . . .	369
Request (Input) QMODEL FM Headers . . . . .	370
Reply (Output) QMODEL FM Headers . . . . .	371
The RAP FM Header under MFS . . . . .	372

**Chapter 18. FM Header Format Reference . . . . . 373**

ATTACH FM Header Format . . . . .	373
Data Descriptor FM Headers . . . . .	382
Error Recovery Procedure (ERP) FM Header . . . . .	383
QMODEL FM Headers . . . . .	383
Reset Attached Process (RAP) FM Header Format . . . . .	390
SCHEDULER FM Header Format . . . . .	390
SYMSMSG Process Headers . . . . .	391

**Part 6. CPI Communications and APPC/IMS . . . . . 393**

**Chapter 19. CPI Communications. . . . . 395**

CPI-C Driven Application Programs . . . . .	395
Distributed Syncpoint/Protected Conversations . . . . .	398

**Chapter 20. Administering APPC/IMS and LU 6.2 Devices . . . . . 405**

APPC/IMS Overview . . . . .	405
APPC/IMS Application Program Interface . . . . .	406
APPC/IMS Application Programs . . . . .	407
Establishing APPC/IMS . . . . .	412
Initializing and Changing LU 6.2 Descriptors . . . . .	418
Using MSC in an APPC/IMS Environment . . . . .	419
Recovering APPC Transactions in an MSC Environment . . . . .	420
Planning for XRF and APPC . . . . .	426
Transaction Retry Characteristics . . . . .	426
Qualifying Network LU Names . . . . .	427
DFSAPPC System Service . . . . .	427
APPC Transaction Security . . . . .	431

**Part 7. SLU P and Finance Communication . . . . . 433**

**Chapter 21. Overview of SLU P and Finance Communication. . . . . 435**

The IMS-SLU P Network . . . . .	436
System Configuration . . . . .	436
SLU P and Finance Workstations . . . . .	436
System Controller Application Program . . . . .	437
Writing the Controller Application Program with MFS and XRF . . . . .	437
Converting Controller Application Programs from Finance to SLU P . . . . .	438
VTAM Facilities Used . . . . .	439

VTAM Commands and Indicators . . . . .	439
Establishing Connection and Specifying Logon Modes . . . . .	441
Establishing Connection with the XRF Complex Bracket and Send/Receive Management . . . . .	442
	443

**Chapter 22. IMS Facilities Used for SLU P and Finance . . . . . 445**

Component Definition . . . . .	445
Terminal-Response Mode . . . . .	447
Defining a Workstation for Terminal-Response Mode . . . . .	448
Output Messages Sent While in a Between-Brackets State . . . . .	449
Designing for Output Messages Sent While in Between-Brackets State . . . . .	450
IMS Message Format Service . . . . .	450
Display Screen Protection for Finance Stations . . . . .	453
Extended Output Component Protection (SLU P) . . . . .	453
Input and Output Editing Options (SLU P) . . . . .	455
Use of Responses or Brackets to Acknowledge Recoverable Input . . . . .	456
Message Recovery . . . . .	457
Message Resynchronization . . . . .	458
Finance and SLU P in an XRF Complex . . . . .	459
Fast Path Messages with Finance and SLU P . . . . .	459

**Chapter 23. Network Operation for SLU P and Finance . . . . . 463**

Starting an IMS Network . . . . .	463
Making IMS Ready . . . . .	463
Session Initiation (Starting Workstations) . . . . .	464
Suspending Output from IMS . . . . .	470
Session Termination . . . . .	470
Shutting Down an IMS Network . . . . .	472
SLU P Messages . . . . .	472
Send/Receive and Bracket Protocol . . . . .	473

**Chapter 24. SLU P Message Protocols 475**

General Format of Input Function Management Headers (Finance) . . . . .	475
Input Message Descriptor Byte (Finance) . . . . .	476
General Format of Input Function Management Headers (SLU P) . . . . .	476
Output Messages . . . . .	479
MFS Distributed Presentation Management Output (SLU P) . . . . .	481
General Format of Output Function Management Headers (Finance) . . . . .	482
General Format of Output Function Management Headers (SLU P) . . . . .	483
Input Response Requirements . . . . .	486
Output Response Requirements . . . . .	487
IMS Transaction Types . . . . .	488
Error Handling . . . . .	490

**Part 8. Appendixes . . . . . 497**

**Appendix A. Using Programmed Symbols for IBM 3270. . . . . 499**

Determining Whether the Buffers Are Loaded . . . 499  
Loading the PS Buffer . . . . . 499  
Solving Load Problems . . . . . 500  
Reloading the PS Buffer . . . . . 501  
Application Design Considerations . . . . . 501

**Appendix B. Bind Parameters for SLU P and LU 6.1. . . . . 503**

Finance Communication System Bind Parameters 503  
LU Type 6.1 Bind Parameters . . . . . 505

**Appendix C. Bind Parameters for SLU 1 and SLU 2 . . . . . 515**

SLU 1 Bind Parameters . . . . . 515  
SLU 2 Bind Parameters . . . . . 517

**Appendix D. Format for CINIT User Data Parameters . . . . . 521**

**Appendix E. SNA Character String Controls . . . . . 523**

Format Controls . . . . . 523  
Control Function Code Assignments. . . . . 524

**Appendix F. Examples Using ISC Edit ATTACH Parameters . . . . . 525**

ATTACH and SCHEDULER Parameters with ISC Edit . . . . . 525  
ATTACH Parameters with the IMS SYSMMSG Process . . . . . 527  
ATTACH and SCHEDULER Parameters with IMS MFS . . . . . 529

**Appendix G. How IMS and CICS Use the ISC Interface . . . . . 535**

Functions Available to the ISC Session . . . . . 535  
General Flow of CICS EXEC Commands within a CICS Application . . . . . 539  
Coding Asynchronous Messages . . . . . 543  
Commands That Should Not Be Used on an ISC Session . . . . . 546  
Selecting Appropriate CICS Installation Options for ISC . . . . . 546  
Coding CICS System Definition Options . . . . . 546

Preparing CICS Resource Definition . . . . . 547  
Defining IMS-CICS LU 6.1 Links . . . . . 547  
Defining Compatible IMS and CICS Nodes . . . . 548  
Defining Multiple Links to an IMS System . . . . 552  
Defining CICS Transactions for IMS-CICS ISC . . . 554  
Application-Related Concepts . . . . . 557  
Coding Function Management Headers for CICS 564  
Recovery and Restart Concepts . . . . . 570  
Handling Transaction Abends . . . . . 575  
Coding CICS Applications for Restart . . . . . 576

**Appendix H. ISC Data Flow Control Examples . . . . . 579**

Non-MFS Bracket and Half-Duplex Protocol Examples. . . . . 579  
MFS Bracket and Half-Duplex Protocol Examples 581  
SBI/BIS Examples . . . . . 585  
Signal Protocol Example. . . . . 586

**Appendix I. ISC Error Recovery Procedure Examples . . . . . 589**

Sender-Detected Error Examples . . . . . 589  
Receiver-Detected Error Examples . . . . . 590

**Appendix J. Sample Program for IMS-CICS ISC . . . . . 593**

Installation Procedure . . . . . 593  
IMS Sample Program (DFSIS00). . . . . 593  
Job Control Statements for the Sample Program 596  
IMS System Definition Statements . . . . . 596  
MFS Formats . . . . . 597  
Program Specification Block (PSB) Generation for the Sample Program . . . . . 598  
Application Control Block (ACB) Generation . . . 599

**Notices . . . . . 601**

Programming Interface Information . . . . . 603  
Trademarks . . . . . 603

**Bibliography. . . . . 605**

IMS Version 9 Library . . . . . 605  
Supplementary Publications . . . . . 606  
Publication Collections . . . . . 606  
Accessibility Titles Cited in This Library . . . . 606

**Index . . . . . 607**



---

## Figures

1. Components of a Network . . . . .	5	44. CICS-to-IMS MSC Using ISC . . . . .	259
2. Basic Shared-Queues Environment . . . . .	13	45. ISC Example 1. IMS-to-IMS Message Switch Routing . . . . .	282
3. Components of a Shared-Queues Environment	14	46. ISC Example 2. IMS-to-IMS Application Routing . . . . .	283
4. Relationship between Physical and Logical Terminals for Output from IMS . . . . .	33	47. ISC Example 3. IMS-to-Other Subsystem Message Switch Routing . . . . .	284
5. Relationship between Physical and Logical Terminals for Input to IMS . . . . .	33	48. ISC Example 4. IMS-Terminal-to-IMS Terminal Message Switch Routing . . . . .	285
6. Possible Physical-To-Logical Terminal Relationships . . . . .	34	49. ISC Example 5. IMS-Terminal-to-Other Terminal Message Switch Routing . . . . .	285
7. A Nonswitched Communications Network	35	50. ISC Example 6. IMS-to-IMS Message Switch Routing with MFS . . . . .	286
8. Sample XRF Complex . . . . .	50	51. ISC Example 7. IMS-to-IMS Application Routing with MFS . . . . .	288
9. MFS Utilities and Their Output . . . . .	75	52. Routing of MSC to an ISC LTERM . . . . .	288
10. Overview of the MFS Online Environment	76	53. Two IMSs Defined to Each Other as ISC Nodes . . . . .	292
11. Overview of the MFS Test Environment	77	54. The Definition for SFIMS and NYIMS	293
12. Message Formatting Using MFS. . . . .	80	55. SFIMS Defined to NYIMS . . . . .	297
13. Example of SDF II Panel Editor . . . . .	82	56. Work Unit Examples . . . . .	305
14. MFS Source Statements . . . . .	83	57. RAP FM Header Example . . . . .	360
15. Sequence of IMS TERMINAL Macros . . . . .	91	58. Participants in Resource Recovery. . . . .	399
16. Cloned Configuration in a Shared-Queues Environment. . . . .	102	59. Distributed Resource Recovery. . . . .	401
17. Partitioned Configuration in a Shared-Queues Environment. . . . .	103	60. APPC Support for IMS . . . . .	406
18. Sample CFRM Policy Containing Definitions of Shared-Queues . . . . .	105	61. IMS-Specific TP_Profile Dialog Panel 1	413
19. Shared-Queues Environment with its MSGQ List Structures . . . . .	112	62. DFSAPPC Message Format . . . . .	428
20. Shared-Queues Environment with its EMHQ List Structures . . . . .	113	63. Termination Processing . . . . .	471
21. Static Resources. . . . .	141	64. Chained Message Interaction between a Finance Communication System and an IMS MPP . . . . .	480
22. ETO Dynamic Resources . . . . .	142	65. User Data Format . . . . .	521
23. Summary of ETO Implementation . . . . .	145	66. Example 1: Message Switch from Other Subsystem Terminal to IMS Terminal . . . . .	525
24. VTAM MODEENT Macro PSERVIC Operand Fields that IMS Uses . . . . .	150	67. Example 2: Other Subsystem Accesses IMS Application Program with Reply Back to Other Subsystem Terminal . . . . .	526
25. MSC Physical Link Types . . . . .	198	68. Example 3: Message Routing . . . . .	527
26. Remote and Local Transactions and Systems	200	69. Example 1: SYSMSC without PRN from Other Subsystem Terminal to IMS A . . . . .	528
27. Remote Transaction Flow . . . . .	201	70. Example 2: SYSMSC with PRN from another Subsystem Terminal to IMS . . . . .	528
28. Routing Path. . . . .	202	71. Example 1: Message Switch from Other Subsystem Terminal to IMS Terminal . . . . .	529
29. Logical Destinations . . . . .	203	72. Example 2: Other Subsystem Terminal Accesses IMS Application Program with Reply . . . . .	530
30. Input, Destination, and Intermediate Systems	204	73. Example 3: IMS MPP Is Accessed from Other Subsystem Terminal with Reply to a Temporary Storage File of the Other Subsystem . . . . .	531
31. System Identifiers (SYSIDs) . . . . .	206	74. Example 4: Message Switch from an IMS Terminal to a Terminal on another Subsystem.	532
32. Message Routing . . . . .	208	75. Example 5: Message Routing . . . . .	533
33. Remote LTERMS . . . . .	210	76. SEND/RECEIVE (Synchronous) Processing	537
34. Link Priorities for a Remote Transaction	221		
35. MSC Traffic Report . . . . .	235		
36. MSC Summaries Report . . . . .	236		
37. MSC Queuing Summary Report . . . . .	236		
38. MSC network without an IMSplex . . . . .	241		
39. MSC network coexisting with an IMSplex with shared queues . . . . .	242		
40. IMS Multiple Systems Coupling and Intersystem Communication . . . . .	254		
41. Existing or New IMS Transactions Invoked from CICS . . . . .	258		
42. IMS MFS DPM Mapping Function Distributed to CICS's BMS . . . . .	258		
43. IMS-to-IMS with ISC . . . . .	259		

77. START/RETRIEVE (Asynchronous) Processing . . . . .	537	90. Example 4: Autopaged Output . . . . .	583
78. Application Program Flow Using SEND/RECEIVE from CICS to IMS . . . . .	540	91. Example 5: Nonpaged Output Message . . . . .	583
79. Application Program Flow Using SEND LAST from CICS to IMS . . . . .	541	92. Example 6: Autopaged Input, Three Chains . . . . .	584
80. Application Program Flow Using RECEIVE from IMS to CICS . . . . .	542	93. Example 7: Autopaged Input, Single Transmission Chain . . . . .	585
81. Application Program Flow Using START/RETRIEVE from CICS to IMS . . . . .	544	94. Example 1: PHS Shutdown Using SBI/BIS . . . . .	585
82. Application Program Flow Using RETRIEVE from IMS to CICS . . . . .	545	95. Example 2: Nonsimultaneous Shutdown Using SBI/BIS by Both Half Sessions . . . . .	586
83. Example 1: Bracket Protocol for a PHS Component Defined to IMS as SINGLE1 . . . . .	579	96. Example 3: Simultaneous PHS and SHS Shutdown Using SBI/BIS Fails Because of Operator Override . . . . .	586
84. Example 2: Bracket Protocol for a PHS Component Defined to IMS as SINGLE2 . . . . .	580	97. Signal Protocol Example . . . . .	587
85. Example 3: Bracket Protocol for a PHS Component Defined to IMS as MULT1 . . . . .	580	98. Example 1: Sender-Detected Error While Sending Demand-Paged Output Message . . . . .	589
86. Example 4: Bracket Protocol for a PHS Component Defined to IMS as MULT2 . . . . .	580	99. Example 2: Sender-Detected Error While Sending Autopaged Output Message. . . . .	590
87. Example 1: Demand-Paged Output, Operator Logical Paging (OLP) Not Defined, Sequential Retrieval Using QGETN FM Header . . . . .	581	100. Example 1: Receiver ERP for an IMS Component Defined as SINGLE1 . . . . .	590
88. Example 2: Demand-Paged Output, OLP Defined, QGET (Last Page Request and by Cursor) Used. QPURGE Used To Dequeue the Message . . . . .	582	101. Example 2: Receiver ERP for an IMS Component Defined as SINGLE2 . . . . .	590
89. Example 3: Demand-Paged SCHEDULER Output, OLP Defined, QGET by Cursor Request for a Page Not within the Range of Output Message . . . . .	583	102. Example 3: Receiver ERP for an IMS Component Defined as MULT1 . . . . .	591
		103. Example 4: Receiver ERP for an IMS Component Defined as MULT2 . . . . .	591
		104. Example 5: Demand-Paged Output with Receiver-Detected Error . . . . .	591

## Tables

1. Licensed Program Full Names and Short Names . . . . .	xii	35. Bracket and Send/Receive Indicators for Output Message: Sent Using ATTACH (no SCHEDULER) . . . . .	336
2. Network Administration Activities . . . . .	23	36. Bracket and Send/Receive Indicators for Output Message: Other Output Message Types . . . . .	337
3. Message Segment Format . . . . .	28	37. VTAM Indicators Sent with the CANCEL Command . . . . .	338
4. Determining Fast Path Recoverability . . . . .	42	38. Resulting DFC States after Sender ERP Purge	341
5. Specifying Terminal Support . . . . .	53	39. Resulting DFC States after Selective Receiver ERP Purge . . . . .	342
6. Rapid Network Reconnect Protocols . . . . .	57	40. VTAM Indicators Sent with LUSTATUS	343
7. Queue Types Maintained in a Shared-Queues Environment . . . . .	97	41. IMS Processing for Sense Code X'0864xxxx'	348
8. Generic Resource Affinities Management and GRETAE Options . . . . .	128	42. IMS Processing for Sense Code X'0865xxxx'	349
9. Mapping for VTAM LUTYPE Value to IMS UNITYPE . . . . .	150	43. IMS Processing for Sense Code X'0866xxxx'	349
10. Mapping for TSPROF Specification to IMS UNITYPE . . . . .	150	44. Sense Codes that IMS Receives. . . . .	354
11. Bits in Byte 12 of the VTAM PSERVIC Parameter. . . . .	153	45. Sense Codes that IMS Sends . . . . .	354
12. Mapping for VTAM LUTYPE, IMS UNITYPE, and Default Logon Descriptor Names . . . . .	164	46. Function Management Header Types	357
13. Summary of Macros for Multiple Systems	218	47. IMS-Supported QMODEL Headers . . . . .	369
14. Commands to Terminate Physical Links	228	48. Attach FM Header Format . . . . .	373
15. MSC Environment Commands . . . . .	229	49. IMS Interpretations for the DPN, PRN, RDPN, and RPRN Fields. . . . .	381
16. MSC Information from the /DISPLAY Command . . . . .	230	50. IMS Actions for the DPN, PRN, RDPN, and RPRN Fields . . . . .	381
17. Commands Used to Control MSC Link Paths	231	51. Input Data Descriptor FM Header Format	382
18. SYSID ownership in an MSC network without an IMSplex . . . . .	242	52. Output Data Descriptor FM Header Format	382
19. SYSID ownership in an MSC network that coexists with an IMSplex. . . . .	242	53. Error Recovery Procedure (ERP) FM Header	383
20. Comparing MSC and ISC Functions . . . . .	255	54. QGET FM Header Format . . . . .	384
21. Facilities Available to CICS START RETRIEVE and SEND RECEIVE USER . . . . .	260	55. QGETN FM Header Format. . . . .	385
22. VTAM Commands and Indicators Sent and Received by IMS . . . . .	264	56. QPURGE FM Header Format . . . . .	386
23. Processing Mode Requested by FM Headers	272	57. QSTATUS FM Header Format . . . . .	387
24. Internal versus External Execution Mode Specification . . . . .	274	58. QXFR FM Header Format . . . . .	387
25. Macro Statements For Defining an ISC Node	291	59. QCURSOR and QCOUNT Values with Sequential Retrieval Requests . . . . .	389
26. BIND Action/Response Matrix. . . . .	310	60. QCURSOR Values with Sequential Retrieval Requests . . . . .	389
27. STSN Primary-to-Secondary Flow. . . . .	314	61. Reset Attached Process (RAP) FM Header Format. . . . .	390
28. STSN Secondary-to-Primary Flow. . . . .	316	62. SCHEDULER FM Header Format. . . . .	390
29. Response and Sync-Point Requests for IMS Input Messages . . . . .	326	63. SYSERROR FM Header Format . . . . .	391
30. Response and Sync-Point Requests for IMS Output Messages . . . . .	328	64. SYSSTAT FM Header . . . . .	392
31. Bracket and Send/Receive Indicators for Messages Sent to IMS: Input Message Type Using ATTACH SCHEDULER . . . . .	331	65. APPC/IMS Default Conversation Characteristics . . . . .	430
32. Bracket and Send/Receive Indicators for Messages Sent to IMS: Input Message Type Using ATTACH (no SCHEDULER) . . . . .	331	66. VTAM Commands and Indicators Sent and Received by IMS . . . . .	440
33. Bracket and Send/Receive Indicators for Messages Sent to IMS: Other Input Message Types . . . . .	332	67. Use of VTAM Bracket and Change-Direction Indicators . . . . .	443
34. Bracket and Send/Receive Indicators for Output Message: Sent Using Attach Scheduler	335	68. Set-and-Test-Sequence-Numbers (STSN) Summary . . . . .	469
		69. Set-and-Test-Sequence-Numbers (STSN) Response Summary . . . . .	469
		70. Input Response Requirements by Message Type . . . . .	486
		71. Output Response Requested by Message Type	487
		72. Finance Communication System Bind Parameters . . . . .	503

73.	Logical Unit Type 6.1 Bind Parameters	505	82.	Defining Compatible CICS and IMS Nodes: RDO	551
74.	IMS-To-Other Secondary Half Session	510	83.	Defining Compatible CICS and IMS Nodes: Macro Level	552
75.	SLU 1 Bind Parameters	515	84.	Defining Multiple Links to an IMS Node	552
76.	SLU 2 Bind Parameters	517	85.	The SEND/RECEIVE and START/RETRIEVE Commands	558
77.	Control Function Code Assignments	524	86.	CICS API for SEND/RECEIVE and START/RECEIVE	558
78.	Functions Available to an IMS-CICS Session for CICS EXEC Commands: CICS Front End	537	87.	Source of Values Placed in the ATTACH FM Header Fields	566
79.	Functions Available to an IMS-CICS Session for CICS EXEC Commands: IMS Front End	538	88.	Source of Values Placed in the SCHEDULER FM Header Fields	568
80.	Functions Available to an IMS-CICS Session for CICS EXEC Commands: MFS and BMS Support	538			
81.	Defining an LU 6.1 Link with Individual Sessions	547			

---

## About This Book

This information is available in PDF and BookManager formats, and also as part of the Information Management Software for z/OS® Solutions Information Center. To view the information within the Information Management Software for z/OS Solutions Information Center, go to [publib.boulder.ibm.com/infocenter/imzic](http://publib.boulder.ibm.com/infocenter/imzic). To get the most current versions of the PDF and BookManager formats, go to the IMS Library page at [www.ibm.com/software/data/ims/library.html](http://www.ibm.com/software/data/ims/library.html).

This book is for system programmers who administer an IMS™ Transaction Manager network. Use this book to design a network that runs with the Virtual Telecommunications Access Method (VTAM®), the Message Format Service (MFS), Multiple Systems Coupling (MSC), Intersystem Communication (ISC), the Extended Terminal Option (ETO), Remote Site Recovery (RSR), and advanced program-to-program communication (APPC)/IMS.

Information about the Open Transaction Manager Access (OTMA) component of IMS can be found in *IMS Version 9: Open Transaction Manager Access Guide and Reference*. OTMA provides an open interface to IMS TM customers. With OTMA, a z/OS or TCP/IP application program can send a transaction or command to IMS without using SNA or VTAM.

Information about the IMS Connect function can be found in *IMS Version 9: IMS Connect Guide and Reference*. IMS Connect provides high performance communications for IMS between one or more TCP/IP or local z/OS clients and one or more IMS systems.

---

## Prerequisite Knowledge

You should first read *IMS Version 9: Administration Guide: System*. Its introductory chapter, which covers planning activities, the IMS environments, and administration concepts, is particularly useful as a background for this book.

You should be familiar with the Systems Network Architecture (SNA), VTAM concepts, and facilities that govern communication between a VTAM application program and a SNA logical unit. See the following publications:

- *Systems Network Architecture Technical Overview*
- *Network Program Products General Information*
- *Systems Network Architecture Format and Protocol Reference: Architectural Logic*

If you use APPC/IMS, you must be familiar with APPC/MVS in order to correctly define APPC/MVS configurations. For more information about APPC/MVS, see *CPI Communications Reference*.

If you implement ISC sessions between IMS and CICS®, you should understand the information in *CICS Intercommunication Guide*.

These publications are also prerequisites:

*Advanced Function for Communication System Summary*

*Network Program Products General Information*

*Parallel Sysplex® Overview: Introducing Data Sharing and Parallelism in a Sysplex*

## IBM Product Names Used in This Information

In this information, the licensed programs shown in Table 1 are referred to by their short names.

*Table 1. Licensed Program Full Names and Short Names*

Licensed program full name	Licensed program short name
IBM® Application Recovery Tool for IMS and DB2®	Application Recovery Tool
IBM CICS Transaction Server for OS/390®	CICS
IBM CICS Transaction Server for z/OS	CICS
IBM DB2 Universal Database™	DB2 Universal Database
IBM DB2 Universal Database for z/OS	DB2 UDB for z/OS
IBM Enterprise COBOL for z/OS and OS/390	Enterprise COBOL
IBM Enterprise PL/I for z/OS and OS/390	Enterprise PL/I
IBM High Level Assembler for MVS™ & VM & VSE	High Level Assembler
IBM IMS Advanced ACB Generator	IMS Advanced ACB Generator
IBM IMS Batch Backout Manager	IMS Batch Backout Manager
IBM IMS Batch Terminal Simulator	IMS Batch Terminal Simulator
IBM IMS Buffer Pool Analyzer	IMS Buffer Pool Analyzer
IBM IMS Command Control Facility for z/OS	IMS Command Control Facility
IBM IMS Connect for z/OS	IMS Connect
IBM IMS Connector for Java™	IMS Connector for Java
IBM IMS Database Control Suite	IMS Database Control Suite
IBM IMS Database Recovery Facility for z/OS	IMS Database Recovery Facility
IBM IMS Database Repair Facility	IMS Database Repair Facility
IBM IMS DataPropagator™ for z/OS	IMS DataPropagator
IBM IMS DEDB Fast Recovery	IMS DEDB Fast Recovery
IBM IMS Extended Terminal Option Support	IMS ETO Support
IBM IMS Fast Path Basic Tools	IMS Fast Path Basic Tools
IBM IMS Fast Path Online Tools	IMS Fast Path Online Tools
IBM IMS Hardware Data Compression-Extended	IMS Hardware Data Compression-Extended
IBM IMS High Availability Large Database (HALDB) Conversion Aid for z/OS	IBM IMS HALDB Conversion Aid
IBM IMS High Performance Change Accumulation Utility for z/OS	IMS High Performance Change Accumulation Utility
IBM IMS High Performance Load for z/OS	IMS HP Load
IBM IMS High Performance Pointer Checker for OS/390	IMS HP Pointer Checker
IBM IMS High Performance Prefix Resolution for z/OS	IMS HP Prefix Resolution

Table 1. Licensed Program Full Names and Short Names (continued)

Licensed program full name	Licensed program short name
IBM z/OS Language Environment	Language Environment
IBM Tivoli® NetView® for z/OS	Tivoli NetView for z/OS
IBM WebSphere® Application Server for z/OS and OS/390	WebSphere Application Server for z/OS
IBM WebSphere MQ for z/OS	WebSphere MQ
IBM WebSphere Studio Application Developer Integration Edition	WebSphere Studio
IBM z/OS	z/OS
IBM z/OS C/C++	C/C++

## How to Read Syntax Diagrams

The following rules apply to the syntax diagrams that are used in this information:

- Read the syntax diagrams from left to right, from top to bottom, following the path of the line. The following conventions are used:
  - The >>--- symbol indicates the beginning of a syntax diagram.
  - The ---> symbol indicates that the syntax diagram is continued on the next line.
  - The >--- symbol indicates that a syntax diagram is continued from the previous line.
  - The --->< symbol indicates the end of a syntax diagram.
- Required items appear on the horizontal line (the main path).



- Optional items appear below the main path.

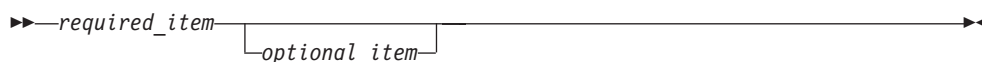

If an optional item appears above the main path, that item has no effect on the execution of the syntax element and is used only for readability.



- If you can choose from two or more items, they appear vertically, in a stack. If you *must* choose one of the items, one item of the stack appears on the main path.

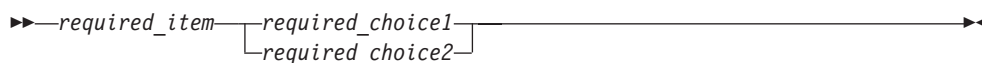

If choosing one of the items is optional, the entire stack appears below the main path.

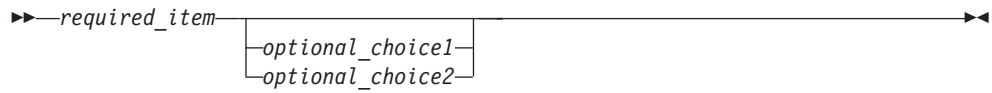

If one of the items is the default, it appears above the main path, and the remaining choices are shown below.

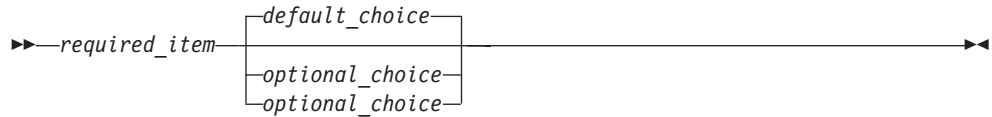

- An arrow returning to the left, above the main line, indicates an item that can be repeated.



If the repeat arrow contains a comma, you must separate repeated items with a comma.



A repeat arrow above a stack indicates that you can repeat the items in the stack.

- Sometimes a diagram must be split into fragments. The syntax fragment is shown separately from the main syntax diagram, but the contents of the fragment should be read as if they are on the main path of the diagram.



**fragment-name:**



- In IMS, a b symbol indicates one blank position.
- Keywords, and their minimum abbreviations if applicable, appear in uppercase. They must be spelled exactly as shown. Variables appear in all lowercase italic letters (for example, *column-name*). They represent user-supplied names or values.
- Separate keywords and parameters by at least one space if no intervening punctuation is shown in the diagram.
- Enter punctuation marks, parentheses, arithmetic operators, and other symbols, exactly as shown in the diagram.
- Footnotes are shown by a number in parentheses, for example (1).



---

## How to Send Your Comments

Your feedback is important in helping us provide the most accurate and highest quality information. If you have any comments about this or any other IMS information, you can take one of the following actions:

- Click the Feedback link located at the bottom of every page in the Information Management Software for z/OS Solutions Information Center. The information center can be found at <http://publib.boulder.ibm.com/infocenter/imzic>.
- Go to the IMS Library page at [www.ibm.com/software/data/ims/library.html](http://www.ibm.com/software/data/ims/library.html) and click the Library Feedback link, where you can enter and submit comments.
- Send your comments by e-mail to [imspubs@us.ibm.com](mailto:imspubs@us.ibm.com). Be sure to include the title, the part number of the title, the version of IMS, and, if applicable, the specific location of the text on which you are commenting (for example, a page number in the PDF or a heading in the Information Center).



---

## Summary of Changes

---

### Changes to the Current Edition of This Book for IMS Version 9

This edition includes technical and editorial changes.

---

### Changes to This Book for IMS Version 9

In addition to editorial changes, this book contains new technical information for IMS Version 9 on the following enhancements:

- The increase in the maximum number of transaction classes from 255 to 999. See “Establishing APPC/IMS” on page 412.
- The MNPS alternative to USERVAR in XRF complexes. See “Planning for the Extended Recovery Facility (XRF)” on page 49.
- RACF enhancements to replace SMU. See “Security Considerations for MSC” on page 225.
- Optional EMHQ in Fast Path Environments. See “Fast Path EMH and Shared Queues” on page 20.
- The option of disabling TM resource sharing in an IMSplex when Resource Manager and a resource structure are present. For more information, see:
  - “Sharing TM Resources” on page 18

A new section, “MSC and IMSplex with Shared Queues: Migration and Coexistence” on page 237, has been added to Chapter 10, “Overview of Multiple Systems Coupling,” on page 197.

---

### Library Changes for IMS Version 9

Changes to the IMS Library for IMS Version 9 include the addition of one title, a change of one title, organizational changes, and a major terminology change. Changes are indicated by a vertical bar (|) to the left of the changed text.

The IMS Version 9 information is now available in the Information Management Software for z/OS Solutions Information Center, which is available at <http://publib.boulder.ibm.com/infocenter/imzic>. The Information Management Software for z/OS Solutions Information Center provides a graphical user interface for centralized access to the product information for IMS, IMS Tools, DB2 Universal Database (UDB) for z/OS, DB2 Tools, and DB2 Query Management Facility (QMF™).

### New and Revised Titles

The following list details the major changes to the IMS Version 9 library:

- *IMS Version 9: IMS Connect Guide and Reference*

The library includes new information: *IMS Version 9: IMS Connect Guide and Reference*. This information is available in softcopy format only, as part of the Information Management Software for z/OS Solutions Information Center, and in PDF and BookManager® formats.

IMS Version 9 provides an integrated IMS Connect function, which offers a functional replacement for the IMS Connect tool (program number 5655-K52). In

this information, the term *IMS Connect* refers to the integrated IMS Connect function that is part of IMS Version 9, unless otherwise indicated.

- The information formerly titled *IMS Version 8: IMS Java User's Guide* is now titled *IMS Version 9: IMS Java Guide and Reference*. This information is available in softcopy format only, as part of the Information Management Software for z/OS Solutions Information Center, and in PDF and BookManager formats.
- To complement the IMS Version 9 library, a retail book, *An Introduction to IMS* by Dean H. Meltz, Rick Long, Mark Harrington, Robert Hain, and Geoff Nicholls (ISBN # 0-13-185671-5), is available from IBM Press. Go to the IMS Web site at [www.ibm.com/ims](http://www.ibm.com/ims) for details.

## Organizational Changes

Organization changes to the IMS Version 9 library include changes to:

- *IMS Version 9: Customization Guide*
- *IMS Version 9: IMS Java Guide and Reference*
- *IMS Version 9: Messages and Codes, Volume 1*
- *IMS Version 9: Utilities Reference: System*

A new appendix has been added to the *IMS Version 9: Customization Guide* that describes the contents of the ADFSSMPL (also known as SDFSSMPL) data set.

The chapter titled "DLIModel Utility" has moved from *IMS Version 9: IMS Java Guide and Reference* to *IMS Version 9: Utilities Reference: System*.

The DLIModel utility messages that were in *IMS Version 9: IMS Java Guide and Reference* have moved to *IMS Version 9: Messages and Codes, Volume 1*.

## Terminology Changes

IMS Version 9 introduces new terminology for IMS commands:

### type-1 command

A command, generally preceded by a leading slash character, that can be entered from any valid IMS command source. In IMS Version 8, these commands were called *classic* commands.

### type-2 command

A command that is entered only through the OM API. Type-2 commands are more flexible than type-1 commands and can have a broader scope. In IMS Version 8, these commands were called *IMSplex* commands or *enhanced* commands.

## Accessibility features for IMS

Accessibility features help a user who has a physical disability, such as restricted mobility or limited vision, to use information technology products successfully.

### Accessibility features

The following list includes the major accessibility features in IMS. These features support:

- Keyboard-only operation.
- Interfaces that are commonly used by screen readers.

**Note:** The Information Management Software for z/OS Solutions Information Center, which is available at <http://publib.boulder.ibm.com/infocenter/>

| imzic, and its related publications are accessibility-enabled. You can operate  
| all features using the keyboard instead of the mouse.

### | **Keyboard navigation**

| You can access the information center and IMS ISPF panel functions by using a  
| keyboard or keyboard shortcut keys.

| You can find information about navigating the information center using a keyboard  
| in the information center home at [publib.boulder.ibm.com/infocenter/imzic](http://publib.boulder.ibm.com/infocenter/imzic).

| For information about navigating the IMS ISPF panels using TSO/E or ISPF, refer  
| to the *z/OS V1R1.0 TSO/E Primer*, the *z/OS V1R5.0 TSO/E User's Guide*, and the  
| *z/OS V1R5.0 ISPF User's Guide, Volume 1*. These guides describe how to navigate  
| each interface, including the use of keyboard shortcuts or function keys (PF keys).  
| Each guide includes the default settings for the PF keys and explains how to  
| modify their functions.

### | **IBM and accessibility**

| See the *IBM Human Ability and Accessibility Center* at [www.ibm.com/able](http://www.ibm.com/able) for more  
| information about the commitment that IBM has to accessibility.



# Part 1. IMS Transaction Manager Network

## Chapter 1. IMS Transaction Manager Network

<b>Overview</b>	3
IMS TM Network Overview	3
Programmable Logical Unit (LU)	6
Communications Controller and Network Control Program (NCP)	6
Virtual Telecommunications Access Method (VTAM)	6
IMS	7
IMS Transaction Manager Services	7
APPC/IMS and LU 6.2 Devices	7
Fast Path	8
Extended Terminal Option (ETO)	8
Intersystem Communication (ISC)	9
Message Format Service (MFS)	9
Multiple Systems Coupling (MSC)	9
The Data Communication Control (DCCTL) Environment	10
Operating an IMS Network	10
Operating the Network with APPC/IMS	11
Initiating a Session with IMS	11
Logging On and Signing Onto IMS	11
Logging Off and Signing Off from IMS	11
The Shared-Queues Environment	12
Benefits of Using Shared Queues	13
Required Components of a Shared-Queues Environment	13
Overview of the Common Queue Server	15
Balancing Sessions With Generic Resources	16
Benefits of Generic Resource Groups	16
Generic Resource Group Definitions	16
Generic Resource Affinity	17
IMSplex Terminal Management	17
Benefits of Managing Resources with a Resource Structure	17
Sharing TM Resources	18
Resource Name Uniqueness	18
Resource Type Consistency	19
Fast Path Expedited Message Handler	19
Fast Path EMH Concepts	19
Criteria for Fast Path Application Programs Using EMH	20

## Chapter 2. Planning the Network

Planning for Network Administration	23
Documenting Network and Terminal Requirements	24
The Terminal Profile	24
Terminals Attached Using VTAM	24
IMS Terminal Network	24
Terminal Connections to IMS	25
XRF Terminal Support	26
Logical Terminals (LTERMs)	26
APPC/IMS and LU 6.2 Terminal Support	26
IMS Messages and Their Scheduling	27
Message Flow within the IMS Online System	29
Conversational Transactions	30

Message Switches	32
Designing Logical Terminal Networks	32
Logical-Terminal Chains	33
Logical-Terminal Queues	33
Separating Input and Output Devices	34
Logical and Physical Terminal Relationships	34
Master Terminal	35
Master Terminals in an XRF Complex	35
NTO Terminals	36
Resource Modes and States	36
Terminal and User Operating Modes	36
Terminal and User States	38
Resource Status Recovery	39
Planning for Security	44
Authorizing Transactions In a TM Network	45
Authorizing Commands In a TM Network	45
Transaction Command Security	46
Password Security	46
Security for APPC/IMS	47
Security for ETO	47
Planning for Fast Path Terminals	47
Planning for the Extended Recovery Facility (XRF)	49
Using MNPS or USERVAR In XRF Complexes	50
Terminals in an XRF Complex	50
Specifying Terminal Support	53
Planning for Rapid Network Reconnect (RNR)	54
Specifying Levels of Support	54
Persistent Session Tracking	55
IMS Shutdown and RNR	56
Using RNR with XRF or VGR	56
Terminal Reconnect Protocols	57
Signon Security	57

## Chapter 3. Defining the Network

Preparing for the Operational Network	59
Coordinating IMS Definition and Network Definition	60
Using IMS as a Host Subsystem	60
Defining VTAM Nodes	61
Estimating VTAM Storage Requirements	61
Determining VTAM Buffer Pool Values	61
Determining the NCP Buffer Pool Values	62
Determining Static and Dynamic Terminal Signon Requirements	62
Checking Requirements for LOGON MODE Tables	63
Specifying Initial VTAM Configurations	64
Using SON/COS Support in IMS	64
Network Operation	65
Starting an IMS Network	65
Session Initiation	66
IMS Transaction Types and Transaction States	66
Defining IMS Transaction Types	66
Determining Transaction States	67
Restarting the Network after Remote Takeover	68
VTAM Definition for Transport Manager	69

VTAM Buffering and Pacing . . . . .	69
VTAM Missing Interrupt Handler . . . . .	69
Defining VTAM for Rapid Network Reconnect (RNR) . . . . .	70
Defining the Level of Persistent Support. . . . .	70
Defining the Level of RNR Support . . . . .	70
<b>Chapter 4. Editing and Formatting Messages . . . . .</b>	<b>73</b>
Message Format Service . . . . .	73
MFS Components . . . . .	74
Administering MFS. . . . .	78
Advantages to Using MFS . . . . .	79
MFS Control Blocks . . . . .	80
Overview of MFS Components and Operation. . . . .	81
Creating MFS Formats with SDF II . . . . .	81
Basic Edit . . . . .	83
IMS Editing for Intersystem Communication (ISC)	84
Transparency Option . . . . .	85
Unprotected Screen Option . . . . .	86
Bypassing MFS Editing . . . . .	86
When To Bypass MFS Editing . . . . .	86
Locking and Unlocking the Terminal Keyboard	86
IMS Sensitivity to Nongraphic Message Data . . . . .	86
Output Message Segment Editing . . . . .	86
Editing of Input Message Segments by MFS . . . . .	87
Editing of Input Message Segments by Basic Edit	87
Controlling Output Devices . . . . .	88
Small Buffer Devices . . . . .	89
Controlling Output . . . . .	89
Using a Printer Component . . . . .	90
Spooled Output Control . . . . .	90
Using Printer Components of the IBM 3270	
Information Display System . . . . .	90
Specifying Candidate Printers . . . . .	91
Operational Considerations . . . . .	91
Sharing Printers between Systems . . . . .	92



---

## Chapter 1. IMS Transaction Manager Network Overview

This chapter introduces the major IMS Transaction Manager (TM) network components, and describes the way communications are established, messages are transmitted, and communications are terminated between IMS and a logical unit.

### In this Chapter:

- “IMS TM Network Overview”
- “IMS Transaction Manager Services” on page 7
- “The Data Communication Control (DCCTL) Environment” on page 10
- “Operating an IMS Network” on page 10
- “The Shared-Queues Environment” on page 12
- “Balancing Sessions With Generic Resources” on page 16
- “IMSplex Terminal Management” on page 17
- “Fast Path Expedited Message Handler” on page 19

---

### IMS TM Network Overview

IMS is a general-purpose database and transaction manager system that provides the necessary support for an advanced telecommunications network. Virtual Telecommunications Access Method (VTAM) controls the physical transmission of data in the network, directing data to IMS from various logical units and from IMS to the appropriate logical units.

An IMS telecommunications network must include the following components:

- IMS
- VTAM<sup>1</sup>
- Communications hardware (such as control units)
- Terminals

The network can optionally include any of the following components:

- IMS Transaction Manager (IMS TM) services, such as:
  - Extended Terminal Option (ETO)
  - Fast Path
  - Message Format Service (MFS)
  - Intersystem Communication (ISC)
  - Multiple Systems Coupling (MSC)
  - Advanced Program-to-Program Communication (APPC)
- Common Queue Server (CQS) and a coupling facility with any of the following structures:
  - Shared-queues structures
  - Shared-data structures
  - Resource structure

---

1. Although IMS uses the network facilities of VTAM, it can also control devices that use Basic Telecommunications Access Method (BTAM) or Basic Sequential Access Method (BSAM). VTAM is the preferred access method for IMS.

## IMS TM Network Overview

- VTAM generic resource groups
- Open Transaction Manager Access (OTMA)
- Common Service Layer (CSL) including:
  - Operations Manager (OM)
  - Resource Manager (RM)
  - Structured Call Interface (SCI)

In addition, an IMS telecommunications network can operate within one of the following frameworks:

- IBM Systems Network Architecture (SNA), which brings together multiple products in a unified design. SNA formally defines the functional responsibilities of the network components.
- A client-server environment, using Advanced Program to Program Communications (APPC) or OTMA.

### Definitions:

- A *logical unit* is an addressable resource that can be an application program, a terminal, or a subsystem such as Customer Information Control System (CICS). A logical unit can also be a component of a general-purpose terminal system that consists of a programmable controller and its attached operator terminals, printers, and auxiliary control units.
- The word *terminal* is used throughout this manual to describe devices and also applies to controllers and remote subsystems. The operator terminals can be keyboard printers, display stations with keyboards, communication terminals, or a mixture of these devices.

A network consisting of IMS and programmable logical units enables users to distribute functions throughout network components. This distribution of function reduces processing requirements that are placed on the central processor (also referred to as the *host*), and it can reduce the impact on the rest of the network when one component encounters a problem.

Figure 1 on page 5 illustrates the components of a complete communications network system. The arrows in Figure 1 on page 5 indicate communications that occur between components. Figure 1 on page 5 shows the following components:

- IMS and its application programs
- Virtual Telecommunications Access Method (VTAM)
- Tivoli NetView for z/OS
- z/OS operating system (including APPC/MVS if APPC/IMS is used)
- IBM 37x5 Communications Controller and Network Control Program (NCP)
- Terminal

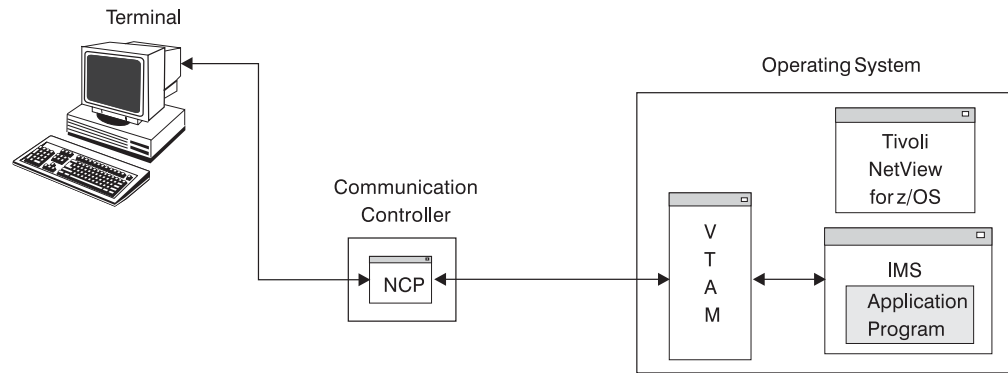

Figure 1. Components of a Network

The following list summarizes how each of the components in Figure 1 participates in the network:

## IMS

- Checks transaction security
- Schedules the proper application program
- Directs output to the proper terminal
- Provides checkpoint and recovery capabilities

## Application program

- Reads data from terminal
- Writes data to processor
- Reads data from processor
- Writes data to terminal

## VTAM

- Connects and disconnects terminal from the network
- Sends data from terminal to IMS
- Permits both monitoring and modifying of the network
- Sends data from IMS to the terminal
- Manages physical network (with Tivoli NetView for z/OS)

## Communications Controller

- Adds line control characters
- Transmits data
- Receives data
- Removes line control characters
- Checks for transmission errors
- Controls buffering

## Network Control Programs (NCP)

- Sends and receives data from communication lines and adapters
- Checks for and records errors

Planning an IMS network requires an understanding of each component and of its relationship to the others.

### Programmable Logical Unit (LU)

#### Definitions:

- A *programmable logical unit (LU)* is an input/output device that is in session with IMS. Application programs in remote logical units can be designed to control more than one terminal.
- When a logical unit informs VTAM that it wants to communicate with IMS, VTAM notifies IMS using the VTAM Logon exit routine. IMS then accepts the request, and VTAM logically connects the logical unit to IMS. This logical connection is called a *session*.

Some of the functions performed by the remote application program include:

- Reading from and writing to associated terminals
- Editing and verifying the data that is received from a terminal
- Reading from and writing to disk storage within the remote LU
- Reading from and writing to the host in which IMS is running
- Editing and verifying data that is received from the host in which IMS is running
- Communicating with other network logical units
- Formatting display and printer devices
- Operating offline when the host, VTAM, IMS, or NCP is unavailable

Depending on the system type, each LU can consist of one or more terminals. An application program that controls an LU consisting of more than one terminal or component must be able to direct output to a specific device. Therefore the application program must be capable of some form of data interrogation in order to make the proper device selection. IMS assists the application program in this process by:

- Allowing LU components to be defined and addressed individually
- Providing, in the header of each output message, the identification of the component to which the message is directed

### Communications Controller and Network Control Program (NCP)

VTAM uses the facilities of NCP, which runs in the 37x5 Communications Controllers. VTAM uses NCP to:

- Control lines and devices that are attached to the controllers
- Transmit data between the logical unit and the host CPC
- Perform error recovery
- Collect statistics about the network

### Virtual Telecommunications Access Method (VTAM)

VTAM controls the allocation of network resources, and enables these resources to be shared among VTAM users. To VTAM, IMS is a single VTAM user; VTAM is unaware of the IMS application programs.

The IMS application programs use the IMS CALL interface to request IMS services; IMS uses VTAM macros in order to activate VTAM facilities.

If APPC/IMS is active, VTAM regards it as a separate user.

**Related Reading:** For more information on VTAM and how it is used, see *Network Program Products General Information*.

### Using VTAM USERVAR With IMS

IMS uses VTAM user variables (USERVARs) in XRF complexes to help maintain and manage sessions when an active IMS subsystem fails. You can, in limited cases, also use VTAM USERVARs to point to a VTAM APPLID of an IMS that is not part of an XRF complex; however, IMS only supports this use of VTAM USERVARs if the IMS being pointed to is the session's primary logical unit (PLU).

For example, you might use a VTAM USERVAR in a non-XRF context if you change the APPLID of an IMS system, but want to temporarily allow LUs to continue connecting to the IMS system using the old APPLID.

**Note:** In an ISC or MSC environment, a VTAM USERVAR might behave unpredictably when pointing to an IMS subsystem that is not part of an XRF complex. This unpredictability is due to the fact that IMS subsystems can be either the PLU or the secondary logical unit (SLU) in sessions between two IMS subsystems in ISC and MSC environments.

### Related Reading:

- For more information on VTAM USERVARs, see the *z/OS V1R4: Communications Server: SNA Network Implementation*
- For more information on XRF, see the *IMS Version 9: Administration Guide: System*

## IMS

IMS comprises two main product features:

- The Database Manager (IMS DB), which can control your databases
- The Transaction Manager (IMS TM), which can control your data communications and application programs

IMS provides:

- Standard functions required by application programs
- An execution environment for concurrently running application programs that serve many online users
- Control of full-function and Fast Path databases

IMS and the application programs that it controls run under z/OS.

---

## IMS Transaction Manager Services

This topic describes several specialized optional Transaction Manager services.

### APPC/IMS and LU 6.2 Devices

APPC/IMS is a part of IMS TM that allows you to use Common Programming Interface Communications (CPI-C) to build CPI application programs. APPC/IMS supports APPC with facilities provided by APPC/MVS.

IMS supports implicit and explicit application program interfaces (APIs) for APPC support. The implicit API for APPC support allows the IMS application program to communicate with APPC devices using the same techniques employed with other

## IMS Transaction Manager Services

remote devices. This support allows an application program, written by a programmer who has no knowledge of APPC LU 6.2 devices, to:

- Be started from an APPC LU 6.2 device
- Receive input messages from originating LU 6.2 devices
- Send output messages back to originating LU 6.2 devices
- Start transaction programs on remote LU 6.2 devices

The same application program can work with all device types (LU 6.2 and non-LU 6.2) without new or changed coding.

The explicit application programming interface (API) for APPC support is the CPI-C interface, and it is available to any IMS application program. The IMS application program can issue calls<sup>2</sup> to APPC/MVS through this interface.

**Related Reading:** For more information on APPC/IMS, see:

- Chapter 19, “CPI Communications,” on page 395
- Chapter 20, “Administering APPC/IMS and LU 6.2 Devices,” on page 405

### Fast Path

Fast Path is capable of performing transaction and database processing at high rates. When your system requirements include a high transaction volume, using Fast Path can be advantageous if you do not require all the facilities of full-function processing. Examples of such applications include teller transactions in banking and point-of-sale transactions (inventory update) in retail marketing. Fast Path input and output messages use *expedited message handling (EMH)* and bypass message queuing and the priority-scheduling process.

**Related Reading:**

- For more information on the Expedited Message Handler (EMH), see “Fast Path Expedited Message Handler” on page 19.
- For more information on message queuing and message scheduling, see “IMS Messages and Their Scheduling” on page 27.

### Extended Terminal Option (ETO)

IMS Extended Terminal Option (ETO) provides dynamic terminal and local and remote logical terminal (LTERM) support for IMS TM.

**Definition:** A *logical terminal (LTERM)* is a user destination. Each logical terminal has a name that points to one physical terminal.

You can add terminal hardware and LTERMs (users) to the IMS without first defining them. ETO gives you the option of eliminating macro statements in the IMS system definition of VTAM terminals and LTERMs. ETO enhances the availability of your IMS by eliminating the need for you to bring the system down in order to add terminals and LTERMs.

ETO also enhances security for the IMS TM user by associating all output with a specific user, instead of with a device. ETO requires the user to sign on.

---

2. You can also use z/OS ATBxxx call services. For information on these call services, see *MVS Programming: Writing Transaction Programs for APPC/MVS*

**Restriction:** The Security Maintenance Utility (SMU) does not support ETO. Security for ETO is enforced using Resource Access Control Facility (RACF®) or a similar product.

ETO reduces the IMS system definition time for those systems where the terminal network is defined dynamically.

**Related Reading:**

- For more information on logical terminals (LTERMs), see “Logical Terminals (LTERMs)” on page 26.
- For more information on ETO, see:
  - Chapter 8, “Overview of the Extended Terminal Option,” on page 139
  - Chapter 9, “Administering the Extended Terminal Option,” on page 147

### Intersystem Communication (ISC)

You can exchange data between your IMS and other external subsystems.

**Definition:** An *external subsystem* is a subsystem that provides a set of database resources that IMS can use, but does not control. Examples of external subsystems to which your IMS can connect include:

- Customer Information Control System (CICS)
- Other IMS's
- User-written subsystems

The session that is created between IMS and an external subsystem is called an *application-to-application session*. The IMS that operates in this session uses a function called Intersystem Communication (ISC), which uses SNA protocols.

**Related Reading:** For more information on ISC, see Chapter 12, “Overview of Intersystem Communication,” on page 253.

### Message Format Service (MFS)

IMS Message Format Service (MFS) is a facility that formats messages to and from terminals, so that application programs need not deal with device-dependent data in input or output messages. An application program can format messages for different device types using a single set of editing logic, even when device input and output differ from device to device.

IMS MFS formats messages to and from user-written programs in remote controllers and subsystems so that application programs need not deal with the transmission-specific characteristics of the remote controller.

**Related Reading:** For more information on MFS, see “Message Format Service” on page 73.

### Multiple Systems Coupling (MSC)

Multiple Systems Coupling (MSC) enables you to enter transactions in one IMS and process them in another IMS. The responses from IMS can be returned to the terminals that entered the transactions, or to other terminals.

**Related Reading:** For more information on MSC, see Chapter 10, “Overview of Multiple Systems Coupling,” on page 197.

---

### The Data Communication Control (DCCTL) Environment

The Data Communication Control (DCCTL) environment allows you to use the IMS Transaction Manager independently of the IMS Database Manager. DCCTL provides improved system performance in terms of throughput, system availability, and integrity. DCCTL can coexist with current IMS application programs and installed terminals.

The following scenarios involving DCCTL do not require modifications to your existing environment:

- Application programs that access external database managers can use DCCTL without any modifications. For example, DCCTL can function as a front-end transaction manager for DB2 UDB for z/OS. DB2 UDB for z/OS subsystems do not require modifications in order to run with DCCTL.
- IMS exit routines and IMS application programs that access external subsystem resources in a DCCTL environment do not require modifications.
- Global resource management is the same in a DCCTL environment as it is in a DB/DC environment.

The following procedures might require modifications for a DCCTL environment:

- Operational procedures
- The general procedure that is produced by the system definition
- Application programs that contain a mixture of calls that access both external subsystems and IMS databases do require changes. DL/I calls result in a status code of AD.

Your existing system definition procedures support the generation of a DCCTL system. DCCTL executes with a collection of control blocks that identifies your data processing environment. These control blocks describe the system, data communication, and transaction manager components.

Using a DCCTL environment class system definition, you can generate a TM batch environment. Using TM batch, you can either take advantage of the IMS Batch Terminal Simulator (BTS) or access DB2 UDB for z/OS systems. TM batch support allows only DBB and DL/I regions. It does not provide DL/I database capabilities.

#### **Related Reading:**

- For more information on accessing DB2 UDB for z/OS, see *Application Programming and SQL Guide*.
- For more information on the DCCTL environment, see *IMS Version 9: Administration Guide: System*.

---

### Operating an IMS Network

Operating a basic IMS network involves:

- Establishing a communication session between a logical unit and IMS
- Sending data between a logical unit and IMS
- Terminating the session between a logical unit and IMS
- Restarting the session after a failure



## Operating the Network with APPC/IMS

APPC/IMS supports IMS commands for network operation, but the LU 6.2 device handles normal operations such as session startup, transaction initiation, and error handling that does not require master terminal operator (MTO) intervention.

## Initiating a Session with IMS

A session can be initiated by a logical unit, by the VTAM network operator, by the IMS master terminal operator (MTO), automatically by VTAM, or by IMS itself. After a logical unit connects to IMS, it remains connected until one of the following actions occurs:

- The logical unit itself requests disconnection.
- The IMS MTO requests disconnection.
- Another VTAM application program requests connection to the terminal.
- IMS, VTAM, NCP, the logical unit, or the entire network is stopped.

After the physical connection between the controller and VTAM is established, an LU-to-LU session is initiated. The LU that is requesting the session informs VTAM that it wants to communicate with IMS. VTAM notifies IMS of the request through the VTAM Logon exit routine. IMS indicates that it will accept the request, and VTAM then logically connects the LU to IMS. A session is required before communication between the LU and IMS can be accomplished. To open a session, all nodes in the communication path (IMS, NCP, line, and station) must be in active status. After a session is established, VTAM directs all data between the logical unit and IMS.

IMS also supports SNA communication links in an Extended Recovery Facility (XRF) complex.

**Related Reading:** For information on establishing sessions in an XRF environment, see:

- *IMS Version 9: Customization Guide*
- *IMS Version 9: Administration Guide: System*

## Logging On and Signing Onto IMS

The following definitions apply to logging onto IMS and signing onto IMS:

### Definitions:

- *Logging on* to a terminal establishes a session with IMS for that terminal.
- *Signing on* to a terminal identifies a user to IMS.

## Logging Off and Signing Off from IMS

The following definitions apply to logging off from IMS and signing off from IMS:

### Definitions:

- *Logging off* from a terminal ends a session with IMS for that terminal.
- *Signing off* from a terminal ends an identification of a user to IMS.

### The Shared-Queues Environment

Operating in a shared-queues environment allows multiple IMSs in a sysplex environment to share IMS message queues and EMH message queues. The IMSs work together as an IMSplex providing a single-image view of multiple IMSs.

The shared-queues environment distributes processing loads between the IMSs in the IMSplex. Transactions that are entered on one IMS can be made available on the shared queues to any other IMS that can process them. Results of these transactions are then returned to the initiating terminal. End users need not be aware of these activities; they view the processing as if they were operating a single-system.

#### **Definitions:**

- A *shared queue* is a collection of messages that are associated by the same queue name. A shared queue is managed by a Common Queue Server (CQS) and can be shared by CQS clients in a IMSplex.
- A *Common Queue Server* receives, maintains, and distributes data objects from a shared queue that resides in a coupling facility list structure for its client.
- A *CQS client* is an IMS DB/DC or DCCTL system that accesses shared queues through its own CQS.
- A *coupling facility* is a special, logical partition that provides high-speed caching, list processing, and locking functions in a sysplex environment.
- A *sysplex environment* is a set of z/OS systems that communicate and cooperate with one another through certain multisystem hardware components and software services in order to process workloads.
- An *IMSplex* is one or more IMS control regions, managers, or servers that work together as a unit. Typically, but not always, IMSs in an IMSplex:
  - Share either databases or resources or message queues (or any combination)
  - Run in an S/390® Parallel Sysplex environment
  - Include an IMS Common Service Layer (CSL)

In general, IMS handles messages in the following manner:

1. IMSs register interest in those queues for which they are able to process messages.
2. When an IMS receives a message and places it on the shared queue, all IMSs that have registered interest in that queue are notified.
3. One IMS retrieves the message and processes it.
4. The IMS that processes the message places a response on the queue.
5. The IMS that submitted the original message is notified that the response message was placed on the queue.
6. The IMS that submitted the original message sends the response message to the originating terminal.

**Related Reading:** For more information on queue types, see “Queue Types” on page 97.

Figure 2 on page 13 shows a basic shared-queues environment.

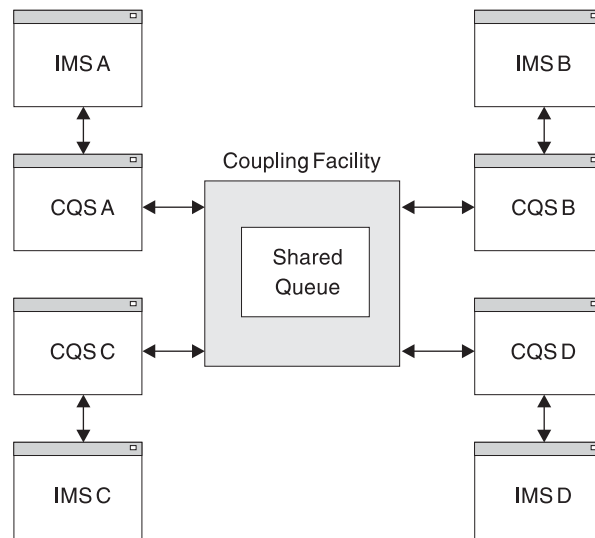

Figure 2. Basic Shared-Queues Environment

### Benefits of Using Shared Queues

The major benefits of operating in a shared-queues environment are:

#### Automatic workload balancing

A message that is placed on a shared queue can be processed by any participating IMS that is available to process work.

#### Incremental growth

You can add new IMSs as workload increases.

#### Increased reliability

If one IMS fails, work that is placed on a shared queue can still be processed by other IMSs.

#### Recommendations:

- Enabling shared queues does not require the use of generic resource groups; however, IBM recommends that you use the two functions together.
- IBM recommends that all data in an IMSplex be shared across the IMSplex.

#### Related Reading:

- For information on generic resource groups, see “Balancing Sessions With Generic Resources” on page 16.
- For information on data sharing, see *IMS Version 9: Administration Guide: System*.

### Required Components of a Shared-Queues Environment

Although you can operate many different configurations of a shared-queues environment, the required components of shared-queues processing, shown in Figure 3 on page 14, include:

#### Common Queue Server (CQS)

One CQS is required for each client. Each CQS accesses the shared queues, which reside on coupling facility list structures.

#### CQS client

One or more IMS DB/DC or DCCTL subsystems that can access the shared queues using CQS client requests.

## The Shared-Queues Environment

### z/OS coupling facility list structures

A type of coupling facility structure that maintains the shared queues.

#### Definitions:

- A *list structure* is an area of storage in a coupling facility that enables multisystem applications in a sysplex environment to share information that is organized as a set of lists or queues. The list structure consists of a set of lists and an optional lock table.
- CQS maintains list structures in pairs, called *structure pairs*, with a primary list structure and an overflow list structure.
- The *primary list structure* contains the shared queues.
- The *overflow list structure*, if defined, contains shared queues that overflow after the primary list structure reaches a predefined threshold.

### z/OS system log

One z/OS system log is used for each structure pair. CQS places recovery information about the work it has processed and about the list structure pair in the z/OS log streams. These log streams are then shared by all CQs that access the list structure pair.

### CQS checkpoint data set

One CQS checkpoint data set is maintained for each structure pair of each CQS. The CQS checkpoint data set contains CQS system checkpoint information.

### CQS structure recovery data sets (SRDSs)

CQS maintains two SRDSs for each structure pair so that shared queues on the structures can be recovered. The SRDSs maintain structure checkpoint information for the shared queues.

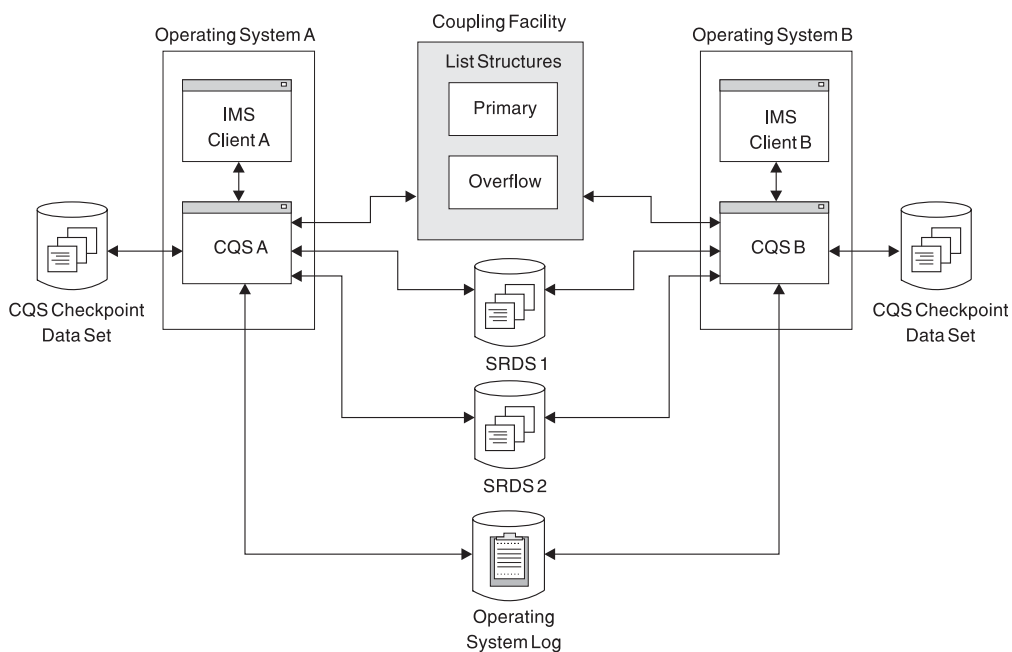

Figure 3. Components of a Shared-Queues Environment

**Related Reading:** For more information on CQS requests and other CQS topics, see *IMS Version 9: Common Queue Server Guide and Reference*.

### Overview of the Common Queue Server

The Common Queue Server (CQS) is an internal interface by which IMS communicates with shared message queues. You can use IMS commands to initiate CQS requests. The CQS address space is started by the IMS.

CQS performs the following services:

- Notifies registered clients when work exists on the shared queues.
- Provides clients with an interface for accessing shared queues and CQS.
- Writes CQS system checkpoint information to a CQS checkpoint data set.
- Writes structure checkpoint information to an SRDS for recovery of a shared-queues list structure.
- Provides structure recovery and overflow processing for the shared-queues list structure.
- Drives the following CQS client exit routines:
  - The Client CQS Event exit routine notifies the client of system events, such as CQS abnormal termination and CQS restart completion.
  - The Client Structure Event exit routine notifies the client of structure events, such as structure copy, structure recovery, structure overflow, structure checkpoint, and structure resynchronization.
  - The Client Structure Inform exit routine notifies the client when work exists on the shared queues.
- Drives the following CQS user-supplied exit routines:
  - The CQS Queue Overflow user-supplied exit routine allows the exit to approve or reject a queue that CQS selects for overflow.
  - The CQS Initialization/Termination user-supplied exit routine is notified when CQS initializes and when CQS terminates after disconnecting from all structures (under normal termination conditions).
  - The CQS Client Connection user-supplied exit routine participates in connecting clients to structures and in disconnecting clients from structures.
  - The CQS Structure Statistics user-supplied exit routine gathers structure statistics during CQS system checkpoints.
  - The CQS Structure Event user-supplied exit routine tracks structure activity, such as structure checkpoint, structure rebuild, structure overflow, and structure status change. It also tracks when CQS connects to a structure or disconnects from a structure.
- Provides the Log Print utility with sample JCL that enables you to print log records from the z/OS log.

#### **Related Reading:**

- For more information on CQS, CQS client routines, and CQS utilities, see *IMS Version 9: Common Queue Server Guide and Reference*.
- For information on IMS commands, see *IMS Version 9: Command Reference*.
- For more information on enabling shared queues, see “Enabling Shared Queues” on page 103.

### Balancing Sessions With Generic Resources

If you are operating in a sysplex environment and have multiple IMSs, you can initiate a session by using the name of a generic resource group. VTAM balances the sessions among generic resource members in a generic resource group. If you do not require the services of a specific IMS, initiate the session using a generic resource name, rather than the APPLID name of a specific IMS. VTAM Generic Resources is intended to run in a sysplex environment, but a sysplex environment is not required.

This topic gives an overview of the benefits and terminology of VTAM Generic Resources. For more information on planning and implementing VTAM Generic Resources, see Chapter 6, “Planning for Generic Resource Groups,” on page 121.

### Benefits of Generic Resource Groups

The benefits of using generic resource groups include:

#### Automatic session workload balancing

Using generic resources is complementary to using shared queues; generic resources distributes network traffic among multiple IMSs, while shared queues distributes back-end application workload.

#### Single-image resources

You can use a single generic resource name to access multiple IMSs, offering a single-system image while you are using the resources of many IMSs.

#### Enhanced IMS system availability

In general, if one IMS fails, you can log on to another IMS in that generic resource group.

**Exception:** If a terminal is ISC, SLU P, or Finance, you might not be able to log on to that terminal. If Resource Manager (RM) is active with a resource structure, you might not be able to log on only if the status recovery mode is LOCAL.

#### Share global messages

You can obtain messages on shared queues from any IMS in the generic resource group.

**Recommendation:** Before attempting to obtain messages from a terminal that is in either conversation or response mode, you must re-logout to the system from which the input was originally submitted. If RM is active with a resource structure and the status recovery mode is LOCAL, you must re-logout to the system from which the input was originally submitted. If the status recovery mode is GLOBAL or NONE, you can logon to any IMS within the generic resource group.

### Generic Resource Group Definitions

#### Definitions:

- A *generic resource group* is a set of IMS subsystems that have the same generic resource name, enabling VTAM to distribute terminal sessions among them.
- A *generic resource member* is an IMS subsystem that belongs to a generic resource group.
- A *generic resource name* is the common name by which VTAM knows all the IMS subsystems that belong to a generic resource group.

- An *APPLID name* is a unique application program name by which VTAM knows an IMS subsystem. In a generic resource group, VTAM uses the APPLID name to differentiate each IMS subsystem.
- In the context of generic resources, an *affinity* is an association between a VTAM logical unit and a specific IMS subsystem in a generic resource group.

### Generic Resource Affinity

VTAM establishes an affinity between a terminal and a specific IMS in the following circumstances:

- For all sessions initiated by IMS
- When logging onto IMS using a generic resource name

Until the affinity is reset, subsequent logons resolve to the same IMS.

Affinity is automatically reset in one of two ways:

- By VTAM at session termination if VTAM-managed affinity is established for the session.
- By IMS at session termination if IMS-managed affinity is established for the session, unless the terminal has end-user significant status in the local IMS (status recovery mode of LOCAL).

#### Related Reading:

- For more information on affinities, see “Determining When Affinities are Terminated” on page 125.
- For information on planning for generic resources, see Chapter 6, “Planning for Generic Resource Groups,” on page 121.

---

## IMSplex Terminal Management

Using Resource Manager (RM) and a resource structure enhances your ability to manage IMSplex-wide TM resources and to share terminal-related information in a DB/DC or DCCTL environment. When operating with the Common Service Layer (CSL), specifically RM, the resource structure provides a way to consistently define and maintain resources across the IMSplex. By sharing resource information throughout the IMSplex, you also gain transparency and state recovery for terminals and users.

This topic gives an overview of the benefits of using RM and a resource structure to manage your TM resources.

**Note:** If you have defined your IMSplex without RM, terminal management is the same as it is for IMS systems running in local mode only.

#### Related Reading:

- For more information about CSL and RM, see *IMS Version 9: Common Service Layer Guide and Reference*.
- For detailed information on globally managing your terminals and users with RM and a resources structure, see Chapter 7, “Managing TM Resources in an IMSplex,” on page 129.

### Benefits of Managing Resources with a Resource Structure

Benefits of using RM and a resource structure to manage IMS TM resources include:

## IMSplex Terminal Management

### Enforcement of resource type consistency

Prevents the same name being used for more than one resource type

### Enforcement of resource name uniqueness

Ensures that certain resources can only be active one at a time within the IMSplex

### Global callable services

Allows exit routines to obtain LTERM, node, and user resource information across the IMSplex

### Terminal and user status recovery

Allows terminals and users to resume work without having affinity to any IMS

### VTAM can manage Generic Resource affinities

Specifying GLOBAL as the status recovery mode allows VTAM to manage Generic Resource affinities instead of IMS. If an IMS system fails, VTAM can reassign terminals to another IMS system even if the terminals have affinity to the failed IMS system.

## Sharing TM Resources

TM resource sharing is automatic when a resource structure is present in an IMSplex with Resource Manager (RM).

When sharing TM resources the following points apply:

- Each IMS connected to the resource structure can use the TM resources of all the other IMS systems connected to the resource structure.
- RM enforces resource name uniqueness among IMS systems connected to the resource structure.
- RM enforces resource type consistency among IMS systems connected to the resource structure.

If you need to disable TM resource sharing while maintaining all of the connections between the resource structure and the IMS systems in the IMSplex, specify STM=NO in the DFSDCxxx PROCLIB member.

### Related Reading:

- For a detailed description of TM Resources, see Chapter 7, “Managing TM Resources in an IMSplex,” on page 129.
- For more information about the DFSDCxxx PROCLIB member, see *IMS Version 9: Installation Volume 2: System Definition and Tailoring*.

## Resource Name Uniqueness

When RM is active and a resource structure is defined, IMS automatically enforces name uniqueness for the following TM resources:

- VTAM LTERMs
- VTAM single-session nodes
- User IDs
- Users

You can disable the enforcement of resource name uniqueness, and TM resource sharing in general, by specifying STM=NO in the DFSDCxxx PROCLIB member.



## Resource Type Consistency

IMS automatically enforces type consistency for TM resources when RM is active and a resource structure is defined in the coupling facility. IMS validates the type of resources for the following message destinations:

- LTERMs
- LTERMs defined as APPC descriptors
- MSNAMEs
- Statically defined transactions
- CPI-C transactions

You can disable the enforcement of resource type consistency when a resource structure is present by specifying `STM=NO` in the `DFSDCxxx PROCLIB` member. After specifying `STM=NO`, resource type consistency is enforced only for statically defined transactions and CPI-C transactions.

---

## Fast Path Expedited Message Handler

This topic briefly describes the Fast Path expedited message handler (EMH) and how it processes Fast Path messages.

### Fast Path EMH Concepts

The following subtopics describe how the Fast Path EMH processes Fast Path messages.

#### Fast Path Message Scheduling

Fast Path schedules input messages by associating them with a load balancing group.

**Definition:** A *load balancing group* is a group of Fast Path input messages that are ready for balanced processing by one or more copies of a Fast Path program. One load balancing group exists for each unique Fast Path message-driven application program.

The messages for each load balancing group are processed by the same Fast Path program. The EMH controls Fast Path messages by:

- Managing the complete execution of a message on a first-in-first-out basis
- Retaining the messages that are received in the control program's storage without using auxiliary storage or I/O operations
- Supporting multiple copies of programs for parallel scheduling
- Requiring that programs operate in a wait-for-input mode

#### Routing Codes and Balancing Groups

IMS places input messages on message queues by using the transaction code, and attempts to process one queue until that queue is exhausted, within limits specified by system definition. Message processing is grouped for load balancing and synchronized for database integrity and recovery.

#### Definitions:

- A *message queue* is a data set on which messages are placed before being either processed by an application program or sent to a terminal.
- A *transaction code* is a one- to eight-character alphanumeric code that invokes an IMS message processing program.

## Using the Fast Path Expedited Message Handler

- A *routing code* is a user-defined code that the EMH uses to enable transactions to be routed to programs within a load balancing group. A message is assigned to a balancing group by a routing code. The routing code can be the same as the transaction code, or it can be any other name you choose.

Incoming messages have preassigned routing codes, or a routing code can be dynamically set for the input message. You declare routing codes during system definition, and they are then associated with individual application programs.

### Fast Path Input Edit/Routing Exit Routine (DBFHAGU0)

All Fast Path-exclusive or Fast Path-potential messages are sent to the Fast Path Input Edit/Routing exit routine so that the application program can examine, change, or edit the input message in the input area.

**Related Reading:** For more information on the Fast Path Input Edit/Routing exit routine (DBFHAGU0), see *IMS Version 9: Customization Guide*.

### Message Buffering with a Fast Path-Capable System

IMS buffer management uses a single EMH buffer when the input message has all of the following characteristics:

- Source terminal is VTAM
- Terminal is not enabled for front-end switch (FES)
- Input is single segment
- Input is non-MFS edited
- Input is not an IMS command
- Execution of at least one transaction is through Fast Path

An expedited message handler (EMH) buffer is dynamically allocated to the terminal when IMS receives the first message that has all of the characteristics listed. The EMH buffer remains allocated to the terminal for use with subsequent input messages (that have the same characteristics) until the user signs off, or until the session terminates. The buffer is then released to the EMH pool.

### Fast Path EMH and Shared Queues

In a shared-queues environment that includes Fast Path, you have the option of sharing Fast Path EMH messages using an EMH queue (EMHQ). The EMHQ distributes the processing of EMH messages among multiple IMSs.

If you do not intend to share EMH messages, you can delete the EMHQ statement from the DFSSQxx PROCLIB member to prevent IMS from allocating the EMHQ structures and data sets.

**Related Reading:** For more information on shared queues, Fast Path, and the EMHQ option, see Chapter 5, “Planning for Shared Queues,” on page 95.

## Criteria for Fast Path Application Programs Using EMH

Application programs that use EMH must conform to all of the following criteria:

- Each transaction must be initiated by a single-segment, response-type message.
- Each input message must require only a single-segment response message or no response.
- The input and output message length cannot exceed the EMH buffer size.
- ETO and LU 6.2 users cannot access main storage databases (MSDBs) with terminal-related keys.

## Using the Fast Path Expedited Message Handler

- No IMS conversational processing is performed.
- Fast Path programs cannot act as automated operator programs or issue IMS commands.
- Fast Path transactions cannot be sent over any of the four types of multiple system coupling (MSC) physical links for processing in another IMS.

|  
|

## Using the Fast Path Expedited Message Handler

---

## Chapter 2. Planning the Network

This chapter describes information that will help you plan your IMS network.

### **In this Chapter:**

- “Planning for Network Administration”
- “Documenting Network and Terminal Requirements” on page 24
- “IMS Terminal Network” on page 24
- “Designing Logical Terminal Networks” on page 32
- “Resource Modes and States” on page 36
- “Planning for Security” on page 44
- “Planning for Fast Path Terminals” on page 47
- “Planning for the Extended Recovery Facility (XRF)” on page 49
- “Planning for Rapid Network Reconnect (RNR)” on page 54

---

### **Planning for Network Administration**

As an IMS network administrator, you should plan for each of the activities listed in Table 2. The table also lists where you can find additional information on each activity.

*Table 2. Network Administration Activities*

<b>Activity</b>	<b>Related Reading</b>
Identifying the terminals and other devices required in the online system, verifying that IMS supports these devices, and identifying any incompatibilities.	For information on the terminals that IMS supports, the communication modes that IMS supports for each terminal, and the features for each terminal, control unit, or CPC, see <i>IMS Version 9: Release Planning Guide</i> .
Establishing appropriate security features in the network	For information on establishing security, see <i>IMS Version 9: Administration Guide: System</i> .
Determining message editing requirements	For information on editing and formatting messages, see Chapter 4, “Editing and Formatting Messages,” on page 73.
Determining requirements for exit routine	For information on using exit routines to customize your IMS network, see <i>IMS Version 9: Customization Guide</i> .
Enforcing suitable naming conventions	For information on establishing naming conventions, see <i>IMS Version 9: Administration Guide: System</i> .
Defining the network at IMS system definition, and coordinating the system definitions for the host	For information on IMS system definition, see <i>IMS Version 9: Installation Volume 2: System Definition and Tailoring</i> .
Defining ETO descriptors and MFS device characteristics table entries	For information on ETO and the MFS device characteristics table, see Chapter 9, “Administering the Extended Terminal Option,” on page 147.
Defining LU 6.2 descriptors to APPC/IMS	For information on APPC/IMS and LU 6.2, see Chapter 20, “Administering APPC/IMS and LU 6.2 Devices,” on page 405.
Testing the readiness of the network	For information on testing the network, see <i>IMS Version 9: Administration Guide: System</i> .

## Planning for Network Administration

Table 2. Network Administration Activities (continued)

Activity	Related Reading
Monitoring the performance of the network, and analyzing message loading, such as transaction routing and message queue size	For information on performance monitoring, see <i>IMS Version 9: Administration Guide: System</i> .

---

## Documenting Network and Terminal Requirements

The size of your IMS installation and your terminal profile determine how you document your network requirements.

### The Terminal Profile

Creating a terminal profile is the best approach for gathering the information you need for your system definition. Your terminal profiles also assist you in coordinating the installation arrangements. They help you describe, to the system programming staff, how each terminal is to be used.

Begin by examining the application program specifications or the hardware plans to identify the terminals that are to be used.

### Terminals Attached Using VTAM

Terminals attached through VTAM are defined according to terminal type. Communication and attachment modes include:

- Binary synchronous communications (BSC)
- Synchronous data link control (SDLC)
- Local attachment (directly to a channel)

When you define your IMS or select an ETO logon descriptor, your choice of terminal type determines the communication protocol and the MFS formatting that IMS uses for that terminal. You can use more than one terminal type for a particular physical terminal; however, your choice must be compatible with the application programs that execute on the IMS.

---

## IMS Terminal Network

An IMS network is characterized by physical terminals and other devices. IMS supports many terminals, including display devices, printers, and remote intelligent controllers.

IMS uses an access method, such as VTAM, to communicate with a physical terminal. Be sure to understand the difference between:

- VTAM's view of terminals that are connected to a host
- IMS's supervision of those connections

VTAM's responsibilities include:

- Receiving the input message and processing it
- Transmitting data
- Managing line and terminal communication status

IMS's responsibilities include:

- Monitoring the message traffic

- Routing messages to application programs
- Handling message storage, scheduling, and recording

Although IMS uses the network facilities of VTAM, it can also control devices that use BTAM and BSAM.

VTAM is the preferred access method for IMS. You can use OTMA for non-VTAM networks.

To describe your desired physical terminal configuration to IMS, you code system definition macros, such as the TYPE macro, that describe the terminal attachments and their characteristics (such as communication type, features, or options). You also define ETO and LU 6.2 descriptors.

### Terminal Connections to IMS

IMS supports various modes of communication or attachment, usually using VTAM. For BTAM, one major distinction is whether the attachment is local (through a channel) or remote (through a communication control unit). Remote attachments are either switched or nonswitched.

#### Definitions:

- *Switched* communication lines permit the attachment of only one remote workstation or terminal at a time to a line; they require that the terminal operator use a modem, which is attached to the remote terminal, in order to establish connection with the computer.
- *Nonswitched* communication lines are dedicated to the terminals that are physically attached to them. A nonswitched line can be either a contention or a polled line.
- A nonswitched line with *contention* allows only one contention-type terminal on the line at one time.
- A *polled* line permits one or more terminals to share the (multipoint) line.

Non-VTAM devices are described to IMS as line groups. Separate line groups are used for terminal configurations with the same communication mode, polling technique, or transmission code.

**Example:** A separate line group would be defined for a locally attached IBM 3270 Information Display System, as well as for a switched IBM 3270.

Each device in a line group is assigned a numeric identifier or address, called the *PTERM*. The order in which the terminals are physically defined to IMS during system definition determines the *PTERM* value.

**Example:** To make two physical terminals on a BTAM line available for use, an operator can enter the following command:

```
/START LINE 4 PTERM 1,2
```

Terminals that are attached by using VTAM are assigned a terminal type. The addresses of the lines and terminals that IMS uses are transparent to IMS, because they are not specified during IMS system definition. Instead, all VTAM resources have names assigned to them.

**Definition:** Each logical unit is assigned a *node name* that your installation defines.

## Understanding the IMS Terminal Network

The node name that is chosen for the VTAM definition is also used in IMS system definition and commands. Using VTAM enables IMS users to share network resources with other VTAM applications.

### XRF Terminal Support

XRF supports all terminals that IMS supports. XRF terminal support is divided into three categories: class-1, class-2, and class-3. See “Terminals in an XRF Complex” on page 50 for details about these classes.

### Logical Terminals (LTERMs)

#### Definitions:

- A *logical terminal (LTERM)* is a symbolic destination that is mapped to a VTAM node or a BTAM physical terminal by the IMS administrator.
- Each logical terminal has an installation-defined name, called the *LTERM name*.

**Related Reading:** For more information on LTERMs, see “Designing Logical Terminal Networks” on page 32.

Reserve one LTERM and identify it as the IMS master terminal. This logical terminal is the control point for the online IMS. Commands associated with this LTERM start and stop the system, control the system resources, and display the status of those resources. The master terminal operator (MTO) can use the /ASSIGN command to alter the physical device that is associated with the LTERM. When ETO users sign on, altering the physical device that is associated with the LTERM is automatic. The device is identified by either the node name or the line number with the physical terminal identifier.

When a user enters a transaction, the logical terminal name is associated with the input message, and input messages are queued by transaction code. The output message queue designation is actually the LTERM name itself. Although this name is often the same for output as for input, an application program can cause the output to be directed to an alternate LTERM. An input terminal can also specify an LTERM name as the destination of a message. A message switching (input) edit routine can append the current input LTERM name to the message.

**Related Reading:** For more information on input edit routines, see *IMS Version 9: Customization Guide*.

### APPC/IMS and LU 6.2 Terminal Support

APPC/IMS does not use an LTERM for input. APPC/IMS provides two facilities (that are similar to LTERMs) for determining output destinations:

- LU 6.2 descriptors allow an IMS LTERM name to define an LU 6.2 destination (specifying LUNAME, TPNAME, and other LU 6.2 destination characteristics). These LU 6.2 LTERMs can be used the same way as regular LTERMs in IMS application programs.
- Side information

**Definition:** *Side information* contains system-defined values provided by CPI Communications (CPI-C), and supplies LU 6.2 destination information. For APPC/IMS to establish a conversation with a partner program, CPI-C requires initialization information, such as the name of the partner program and the name of the LU at the partner’s node. CPI-C provides a way to use system-defined values for these required fields. These system-defined values are specified in the side information, and are accessed by a symbolic destination



name. The symbolic destination corresponds to an entry in the side information containing the partner\_LU\_name, the mode\_name, and the TP\_name.

**Related Reading:** For more information on side information, symbolic destination names, and the entries in the side information, see *MVS Planning: APPC Management*.

## IMS Messages and Their Scheduling

**Definitions:** An *IMS message* can be one of four types of data communication for which IMS controls processing:

### Transactions

*Transactions* are input messages that are destined for processing by application programs. Transactions are identified by a one- to eight-character *transaction code*. Transactions can be entered at terminals or generated by application programs. In a multiple-systems environment, a transaction can originate in a remote IMS, or in another subsystem (like DB2 UDB for z/OS).

### Messages sent to LTERMs

Messages that are sent to LTERMs are identified by LTERM names. These messages can be either of the following types:

- Output messages sent from application programs to communicate with a logical terminal. They usually acknowledge or give results of work, and are sent to the originating terminal. Application programs can also send output to logical terminals other than the one that originated the input message.
- Input messages whose destination is a logical terminal. This message type is known as a *terminal-to-terminal message switch*. The text of the message becomes the output message to the destination LTERM.

### IMS commands

IMS commands are entered by terminal users who request that IMS display or alter the status of one or more IMS resources. Most commands originate from the master terminal operator (MTO), but other terminals, as well as application programs, can also enter them.

### DFSAPPC

DFSAPPC is an IMS service that is used for exchanging messages between LU 6.2 devices, or between any combination of LU 6.2 and non-LU 6.2 devices. Messages are delivered by allocating a new conversation with the designated LU 6.2 destination device. If the allocated conversation fails, the output is stored for future delivery. Messages are held on the IMS message queue until they can be successfully delivered.

**Related Reading:** For more information on DFSAPPC and message switching, see Chapter 20, "Administering APPC/IMS and LU 6.2 Devices," on page 405.

## Message Queuing

All input and output messages are queued in IMS-controlled virtual storage. Most command output is queued in virtual storage. Application programs handle messages serially if SERIAL=YES is specified on the TRANSACT macro.

If virtual storage is exceeded, messages are saved on direct-access storage. In this way, messages can be received as input or saved for output, although the resources that are necessary to process them might not be immediately available.

## Understanding the IMS Terminal Network

The maximum number of concurrent terminal I/O requests and the amount of virtual storage to hold the messages are specified during IMS system definition. Both variables can be altered when IMS is started.

### Message Segments

When a terminal is used to enter data into the IMS online system, the input can consist of either single segments or multiple segments. A sequence of several segments might be required to specify a message that can be interpreted by an application program. The device operation determines the end-of-segment.

For input, detection of the end-of-message condition by IMS indicates that a complete message has been received.

When the first end-of-segment condition is detected, IMS examines the beginning of the segment to find a destination. If a destination is declared to be a single-segment message, the end-of-segment signals the end-of-message.

After editing, the first (or only) segment of a message has the following structure:

<b>LL</b>	<b>ZZ</b>	<b>DEST-CODE</b>	<b>b</b>	<b>MMMM</b>
2 bytes	2 bytes	1 to 8 bytes	1 byte	message text

These parameters are explained in Table 3.

Table 3. Message Segment Format

Message Segment Part	Bytes	Explanation
LL	2	Total length of segment including LL and ZZ parts
ZZ	2	Reserved halfword
DEST-CODE	1 to 8	Destination code (usually a transaction code)
MMMM	Varies	Message text

Each input message is uniquely identified by its destination code. The destination is normally a transaction code, but it can also be an IMS command or LTERM for message switching.

### Invalid Destinations

Even when the destination code meets normal resource naming conventions, the input destination can be incorrect:

- If ETO is not active, destinations that cannot be identified in IMS are considered invalid, and the input message is rejected.
- If ETO is active, IMS assumes these destinations are LTERM names and creates dynamic user structures. If the destination is invalid, a *dead-letter queue* is created. Several commands are provided, including the /DISPLAY command, for the MTO to process the dead-letter queues.

**Related Reading:** For more information on how ETO processes dead-letter queues, see “Asynchronous Output to an Invalid Destination” on page 188.

### Transaction Codes

The transaction code has optional attributes that affect the processing program’s scheduling eligibility by the IMS control program.

Application programs are defined in separate but related macro instructions. The application program that is designated to process a particular transaction code is

considered by IMS to be another transaction attribute. An application program might process several transaction codes, but a transaction code can be associated with only one program.

### Message Scheduling

**Definition:** *Message scheduling* is the process by which a completely received input transaction is united with its associated application program for processing.

Some of the factors that affect the message scheduling process are:

- The variable attributes associated with the transaction code
- The number and relative importance of other transaction codes
- The number of received messages that are not yet processed
- The intent of associated application programs toward the data to be processed
- The amount of currently available space in control-block storage pools and buffers

In addition, each of the following activities affect the message scheduling process:

- Selecting system definition options
- Designing and using databases
- Specifying buffer sizes
- Declaring and selecting transaction code priorities

By properly combining these activities, you can manipulate the sequence in which messages are processed and enhance system performance.

**Related Reading:** For more information on monitoring the performance of the IMS network, see *IMS Version 9: Administration Guide: System*.

### CPI-C Transactions

IMS resources are made available to the CPI Communications driven application program when the application program issues the APSB (Allocate\_PSB) call. The CPI Communications driven application program can use the SAA<sup>®</sup> Resource Recovery Commit (SRRCMIT) and Backout (SRRBACK) calls to initiate an IMS synchronization point or backout. CPI Communications driven application programs should use the SAA Resource Recovery calls to initiate an IMS sync point prior to program termination.

**Definition:** A *synchronization point* (also referred to as a *sync point* throughout this manual) is an occurrence within a program or subsystem wherein resources are committed and a reference point is established for subsequent restart, if necessary.

**Recommendation:** Define CPI transactions with a different message class from that used for non-CPI transactions.

**Related Reading:** For more information on CPI Communications driven application programs, see Chapter 20, “Administering APPC/IMS and LU 6.2 Devices,” on page 405.

## Message Flow within the IMS Online System

This topic describes the events that take place as a message that is entered at a terminal flows through an IMS online system. Although some exceptions to the order of events and processing exist, the majority of transactions are processed this way.

## Understanding the IMS Terminal Network

IMS provides two ways to customize processing: basic edit (the default) and MFS.

**Related Reading:** For more information on basic edit and MFS, see Chapter 4, “Editing and Formatting Messages,” on page 73.

### Message Flow from Terminal to Program

The initial entry from a terminal is a message that is processed asynchronously by IMS. After the message is received from the terminal, the message is formatted using basic edit, MFS, or exit routines.

The IMS message scheduler then uses the status of the message queues and a prioritizing algorithm in order to select the next transaction to schedule. When the program is selected for scheduling in the dependent region, the first segment of the message is made available to the program.

### Message Flow from Program to Output Terminal

While the application program is executing, it can use DL/I calls to access databases. The data communication support of DL/I is used by the program to request messages, using the GU function for the first message segment and the GN function to retrieve subsequent message segments. The program can then send a response to the entering terminal by inserting the reply to the I/O PCB. The entering terminal’s LTERM is the I/O PCB after a successful GU call.

If the message is handled by MFS, it can be transformed from the program output format to the device output format. Otherwise, the message is passed unchanged to the device.

When the output message has been completely received by a terminal or by a program, it is dequeued. Any failure in message delivery causes IMS to keep the recoverable message queued for a later delivery.

### Message Flow from Program to Alternate Destination

The application program can also send output to an alternate destination. Using an alternate PCB, the program can insert a message to another LTERM. In this case, the message handling is the same, but the message queue on which it is placed has a different LTERM name.

### Message Flow from Program to Program

The application program can also use the alternate PCB to send a message to a program; that is, it can generate a secondary transaction that is placed on a message queue. The processing of the secondary transaction is dependent on the selection of the transaction by the scheduling algorithm.

## Conversational Transactions

**Definition:** *Conversational transaction processing* allows you to retain message continuity from a given terminal, even when the program that processes the conversation is not retained in storage throughout that conversation.

When the transaction is defined as conversational, the application program can use a scratch pad area (SPA) in order to interrelate messages from a given terminal.

**Definition:** The *scratch pad area (SPA)* is a work area used in conversational processing in order to retain information from an application program across executions of the program. A unique SPA is created for each conversation.

### Contents of the SPA

Typical contents of the SPA are data items entered at the terminal and data that is retrieved from databases to be saved between iterations of the conversation. To simplify operator procedure and application design, database updates are retained in the SPA until the last iteration of the conversation.

Any subsequent data entry from a terminal that is already operating in conversational mode causes a message processing program (MPP) to receive both the contents of the SPA and the input terminal data. Each input message is considered an individual unit of work. Each interaction can be with a different program, although the same program is typically used.

### Message Processing for Conversational Transactions

When the message is a conversational transaction, the following sequence of events occurs:

- IMS removes the transaction code and places it at the beginning of a message segment. The message segment is equal in length to the SPA that was defined for this transaction during system definition. This is the first segment of the input message that is made available to the program. The second through the *n*th segments from the terminal, minus the transaction code, become the remainder of the message that is presented to the application program.
- When the conversational program has prepared its reply, it inserts the SPA to IMS. The program then inserts the actual text of the reply as segments of an output message.
- IMS saves the SPA and routes the message to the input LTERM.
- If the SPA insert specified that another program is to continue the same conversation, the total reply (including the SPA) is retained on the message queue as input to the next program. This program then receives the message in a similar form.
- A conversational program must be scheduled for each input exchange. The other processing continues while the operator at the input terminal examines the reply and prepares new input messages.
- To terminate a conversation, the program places blanks in the transaction code field of the SPA, and inserts the SPA to IMS.
- The conversation can also be terminated if the transaction code in the SPA is replaced by any nonconversational program's transaction code, and the SPA is inserted to IMS. After the next terminal input, IMS routes that message to the other program's queue in the normal way.

### ETO Conversations

ETO conversations maintain associations with users, rather than with terminals. The conversation is associated with the terminal only while the user is signed on. The conversation can be restarted on any other ETO terminal.

**Related Reading:** For more information on ETO, refer to Chapter 9, "Administering the Extended Terminal Option," on page 147.

### Program Switches for Conversational Programs

A conversational program can use a deferred program switch or an immediate program switch.

### Definitions:

## Understanding the IMS Terminal Network

- During a *deferred program switch*, the program responds to the originating terminal but causes the next input from the terminal to go to another conversational program.
- During an *immediate program switch*, the program passes the SPA (and, optionally, a message) to another conversational program without responding to the originating terminal. In this case, it is the next program's responsibility to respond to the originating terminal.

**Related Reading:** For more information on conversational programs and message switching, see *IMS Version 9: Application Programming: Transaction Manager*.

## Message Switches

**Definition:** A *message switch* occurs when an input message specifies an LTERM name instead of a transaction code. IMS formats the message and inserts it into the output message queue for that LTERM.

---

## Designing Logical Terminal Networks

The IMS system definition describes the characteristics and relationship of:

- Communication lines
- Static terminals
- Logical terminals<sup>3</sup> (LTERMs)

When only one user operates a physical terminal, only one logical terminal is associated with that physical terminal. If multiple users operate a physical terminal, the terminal is associated with many logical terminals.

You can structure the IMS system definition so that a separate logical terminal is assigned for each user of a particular static terminal.

**Definitions:** The information in this topic uses *physical terminal* to represent both:

- A *node*, for VTAM devices
- A *PTERM*, for BTAM devices

Logical terminals can be assigned to physical terminals for both input and output. When a logical terminal is assigned to a physical terminal for output, all messages that are sent to that logical terminal are transmitted to its associated physical terminal. More than one logical terminal can be assigned to a given physical terminal for output. Only one physical terminal can receive the output for a given logical terminal. The relationship between physical and logical terminals for output is shown in Figure 4 on page 33.

---

3. For a nonswitched terminal, the relationship between a physical terminal and a logical terminal within IMS is a static relationship defined during system definition.

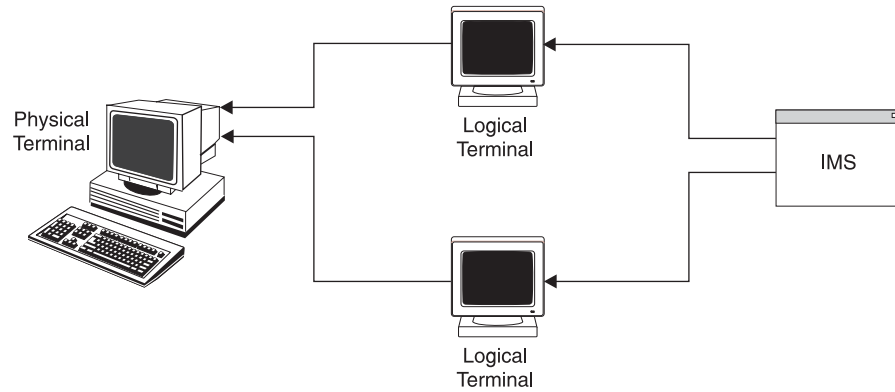

Figure 4. Relationship between Physical and Logical Terminals for Output from IMS

### Logical-Terminal Chains

When a logical terminal is assigned to a physical terminal for input, any message that is entered from the physical terminal is considered to have originated at the logical terminal. When more than one logical terminal is assigned to a physical terminal for input, a chain of input logical terminals is formed. Any input from the physical terminal is considered to have originated at the first logical terminal on the chain. Figure 5 shows the relationship between physical and logical terminals for input.

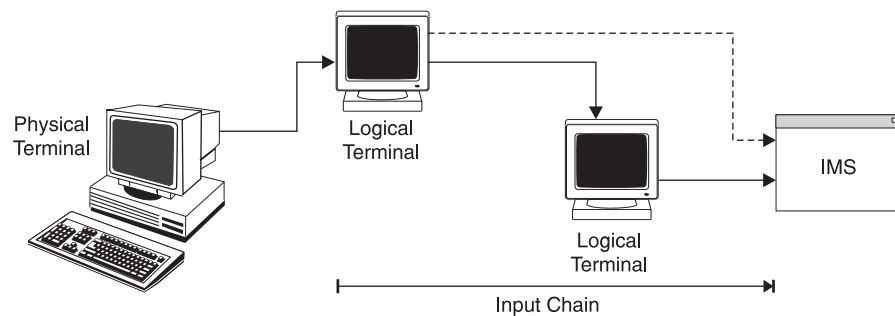

Figure 5. Relationship between Physical and Logical Terminals for Input to IMS

If the first logical terminal is not allowed to transmit a message (for example if it is not authorized or it is a stopped logical terminal), all logical terminals on the input chain are interrogated in chain sequence for their ability to transmit messages. If the physical terminal is a Finance, SLU 1, SLU P, or LU 6.1, only the logical terminals associated with the input component are scanned. The first appropriate logical terminal found is considered the originator of the message. If no appropriate logical terminal is found, the message is rejected with an error message.

### Logical-Terminal Queues

Using a message queue for received input messages or for pending output messages enables an application program to be independent of the arrival time and message transmission. Because this message queue is associated with a logical terminal, rather than with a physical terminal, the message queue can be moved from device to device, independent of the application program. The message queue can even be moved among device classes.

## Designing Logical Terminal Networks

Logical terminals provide stability for application programs. Regardless of how the physical terminal network changes, the application programs remain insensitive to these changes.

The application program interface to a logical terminal is conceptually the same as that for the database system:

- GU calls retrieve message segments from a queue.
- ISRT calls insert message segments to a queue.

## Separating Input and Output Devices

In certain application programs, it might be necessary to associate a different physical device for output than the one that issued for input. If the physical terminal type is an input-only device and output is required, a different device must be associated for output. IMS system definition and commands support assignment of output devices that are different from the input device. For example, the application program that is processing a message from a display might need to send some of the output to a printer. The possible physical-to-logical relationships are shown in Figure 6.

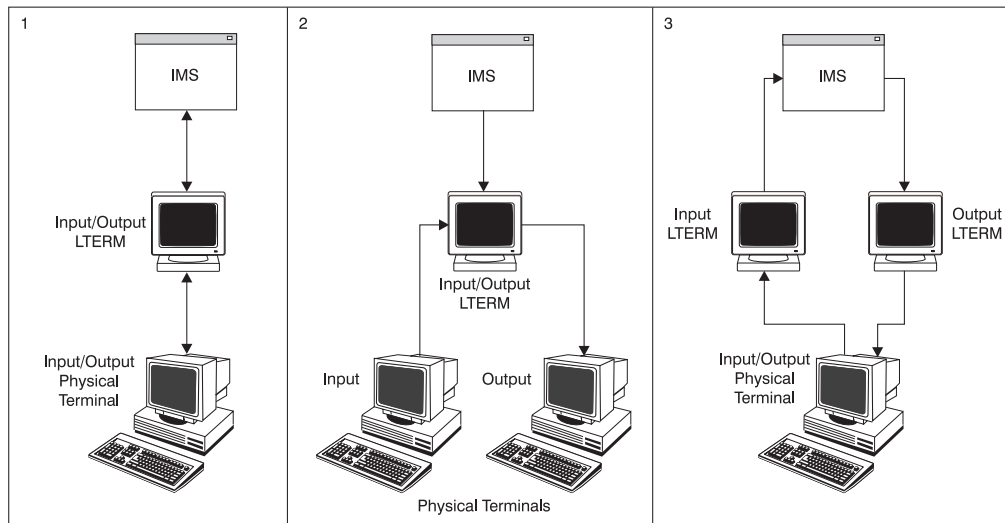

### Notes To Figure Regarding Applications

1. Normal assignment of one or more logical terminals or physical terminals. Output is sent to input terminal. Application is insensitive.
2. Alternative assignment: Input and output sent using same logical terminal. Output is sent to different physical terminal. Application is insensitive.
3. Application uses specific logical terminal for output. Application is insensitive to input.

Figure 6. Possible Physical-To-Logical Terminal Relationships

## Logical and Physical Terminal Relationships

Figure 7 on page 35 shows the communication flow between a terminal user, a physical terminal, a communication line, and a logical terminal in a nonswitched communications network.



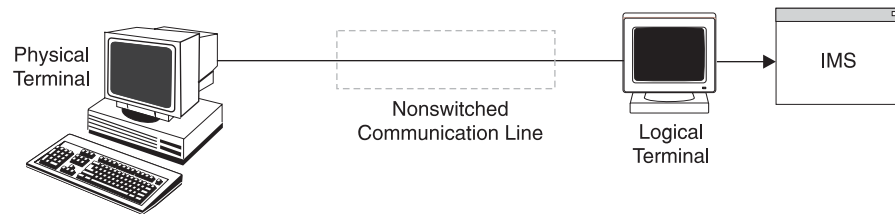

Figure 7. A Nonswitched Communications Network

IMS system definition describes the characteristics and relationship of physical terminals, communication lines, and logical terminals. On a nonswitched communication line, the relationship between a physical terminal at one end and a logical terminal within IMS at the other end is a stable relationship defined during system definition or during signon for ETO terminals.

Except for LU 6.1, terminals using VTAM have the same physical-to-logical terminal (PTERM-to-LTERM) relationship as a terminal on a BTAM nonswitched line.

The relationship that is established between a physical terminal and one or more logical terminals at system definition can be changed using commands or by creating a new system definition. The `/ASSIGN` command dynamically changes logical and physical relationships, and it is usually executable only from the master terminal.

### Master Terminal

The master terminal is the central point of control for IMS. If a VTAM master terminal is defined, IMS establishes a connection with it during startup.

**Recommendation:** Although several device types are supported, a VTAM SLU 2 device is the preferred type for the master terminal.

**Restriction:** Neither an ETO terminal nor an LU 6.2 terminal can be defined as the primary or secondary master terminal.

The master terminal operator (MTO) must be familiar with all aspects of operating the system. The physical location of the master terminal in relation to the computer console is important. If, for security reasons, the MTO and master terminal are not close together, telephone communication should be provided.

### Master Terminals in an XRF Complex

In an XRF complex, each IMS must have its own master terminal, and it can have a secondary master terminal. Typically, the secondary master terminal is a printer (output-only device type). System messages for the active and alternate subsystems go to their respective master terminals.

During a takeover, the console operators must know the status of the takeover on both systems. The operator at the alternate subsystem must know when I/O prevention in the failed active subsystem is complete; terminal switching of class-3 terminals and failed class-2 switch attempts must be handled.

**Related Reading:** For a list of devices that can be defined as primary and secondary master terminals, see *IMS Version 9: Administration Guide: System*.

### NTO Terminals

When using the NTO licensed product, VTAM can support some start-stop and teletype devices, known as *NTO devices*.

The receipt of a message can be confirmed by using transaction-response mode to “lock” the keyboard following the input entry. When IMS responds with available output to a particular terminal for a specific transaction, it “unlocks” the keyboard and sends the data.

Even if the NTO devices are used primarily for inquiry transactions, the transactions can be made recoverable. Because input is not acknowledged, the application program should indicate in the output response the inquiry transaction that caused it.

Both input and output editing routines <sup>4</sup> can be made available for transactions using NTO devices.

Because NTO uses VTAM, IMS is not aware of whether a terminal user is logging on to a session or is logging off. Therefore, existing session status might cause problems when one terminal user ends a session and another terminal user resumes the session. This problem can be minimized by defining all NTO devices as Response mode.

To avoid the problem of continuing session status, a terminal user can clear any preset transaction codes that were previously set using /SET commands by entering the /RESET command either:

- Before issuing the /RCLSDST command when ending an NTO session
- Before issuing the /SIGN ON command when starting an NTO session

A terminal user who enters /RCLSDST or the MTO who enters /CLSDST terminates a session but does not reset conditions that were set during that session.

**Related Reading:** For more information on dynamic NTO terminals, see “NTO Devices” on page 154.

---

## Resource Modes and States

IMS keeps three types of status information for the terminals in the network:

- The mode of operation
- The state of an inoperable terminal (such as temporarily unusable)
- The recovery status

### Terminal and User Operating Modes

A terminal can be in more than one of the following modes at the same time.

#### Response Mode

Response mode is established through static terminals, ETO users, or transaction specifications. Response mode can be used with full function or Fast Path processing. In response mode, after the entry of an input message, the terminal is locked until a reply is received, and no additional incoming data is accepted.

---

4. These routines are provided by your installation and are entered after MFS processing.

### Definitions:

- For operator-driven terminals like 3270s, *locked* means that the keyboard is locked.
- For programmable terminals like LU Ps, *locked* means that IMS delays the acknowledgment of the input message until the output message is ready to be sent.

For LU 6.2, the originator of the transaction must issue a Receive command to get the response message (synchronous output). Failure to do so is treated as a protocol violation. Depending on the system, the application program could fail and IMS could send an error message.

Terminal-response mode is terminated when the response has been sent and dequeued. If Fast Path is used, terminal-response mode is automatically continued following an IMS failure, when a static terminal logs off, or when an ETO user signs off. If full-function operation is used, terminal-response mode is terminated when IMS is restarted, when a static terminal logs off, or when an ETO user signs off.

The ETO user, not the terminal, is in response mode. If the user signs off and Fast Path is used, response mode is recovered for the user, but the terminal is no longer in response mode. The user cannot enter another transaction until the response to the first transaction is received.

**Related Reading:** For more information on ETO terminals, see Chapter 9, "Administering the Extended Terminal Option," on page 147.

### **Conversation Mode**

After you enter a transaction that is defined using the SPA= parameter on the TRANSACT macro, the terminal is in conversation mode. While the terminal is in conversation mode, other transactions cannot be entered from that terminal. However, the terminal is not locked, in the same sense that response mode locks the terminal. The terminal remains in conversation mode until the conversation is terminated, when the message has been sent and dequeued, and the application program has placed blanks in the transaction code field in the scratch pad area (SPA).

A conversation can abnormally terminate under the following conditions:

- When an application program abends
- When the IMS MTO issues an /EXIT command, a /START NODE command, or a /START USER command
- When an inconsistent definition exists in the application program between IMS and MSC

For LU 6.2, all iterations of the IMS conversation must use the same LU 6.2 conversation; each iteration of the IMS conversation is demarcated by using the LU 6.2 CMPTR (Prepare\_To\_Receive) call. If the LU 6.2 conversation ends prior to the end of the IMS conversation, the IMS conversation is abnormally terminated.

## Understanding Terminal Modes and States

The ETO user, not the terminal, is in conversation mode.

### Exclusive Mode

A terminal is placed in exclusive mode when the /EXCLUSIVE command is issued. The Exclusive mode:

- Restricts the output received by the terminal.
- Remains with ETO users after they sign off. ETO users that sign off while they are in exclusive mode remain in exclusive mode when they sign on the next time.
- Terminates with an /END or /START NODE command.

### Lock Mode

Lock mode prevents a terminal from sending and receiving messages. A terminal, node, or logical terminal (LTERM) is placed in lock mode when the operator issues the /LOCK command. Lock mode is reset by issuing the /UNLOCK command or the /IAM command.

### Test Mode

Test mode ensures that any input message entered into a terminal is transmitted back to the terminal. A node is placed in test mode by the /TEST command. Test mode is reset by an /END command or a /START command. Test mode is not significant and is not carried across restart and ETO signoff and signon.

**Related Reading:** For more information on the /EXIT, /START NODE, /START USER, /EXCLUSIVE, /END, /LOCK, /UNLOCK, /IAM, and /TEST commands, see *IMS Version 9: Command Reference*.

## Terminal and User States

The states in which a terminal is inoperable include:

### Stop State

The stopped state prevents the delivery of any output queued on a logical terminal that is associated with a physical terminal.

The /STOP NODE command results in the termination of the session between IMS and the node. This termination occurs immediately for most devices but only at the end of the message for 3270 devices and SLU 2 devices. The /STOP NODE command also prevents a new session until a /START command or /RSTART command is issued.

The /STOP command, the /PSTOP command, and the /MONITOR command also cause a terminal to enter the stopped state. This state is reset by the /START command or /RSTART command. The /STOP NODE or USER command allows ETO users to retain their status after signoff or logoff.

### QERROR State

A logical terminal is placed in a stopped state if an I/O error is encountered while attempting to read from or write to a message queue. This condition is reset when the MTO operator issues a /START command.

### QLOCK State

A logical terminal is prevented from sending any additional output until the locked state is reset by a specific request received in the LU 6.1 session. The LTERM is also prevented from receiving input that might create additional output. This condition is reset when the MTO issues a /START command. A /PSTOP or /PURGE command is ignored for LTERMs that are in QLOCK state.

### INOP State

The physical terminal is considered inoperable by IMS device support whenever an error is detected and put in the INOP state. All logical terminals associated with this physical terminal are also considered inoperable. The /START or /RSTART command resets the inoperable condition.

### COMPINOP State

Component inoperative can be set in one of two ways:

- When an error is detected that is isolated to a component of the terminal
- When the /COMPT or /RCOMPT command is issued for terminals that are defined to VTAM

All logical terminals associated with this component are ineligible for message output. The component inoperative state is reset when the operator issues a /START LINE PTERM command, a /START NODE command, another /COMPT command, or a /RCOMPT command. Special signals from the device, such as device end from a 3270 device or the “component available” status from a SLU 1 can also cause a reset.

**Related Reading:** For unique device considerations, see *IMS Version 9: Operations Guide*.

### PAGE, SCREEN, and COMPONENT PROTECTION State

This is a state supported for video terminals, SLU P, Finance, and LU 6.1 devices. Logical terminals associated with these physical terminals are not eligible for output selection.

**Related Reading:** For more information on screen protection for the IBM 3270 devices, see *IMS Version 9: Operations Guide* and *IMS Version 9: Application Programming: Transaction Manager*.

### SNA QUIESCE State

When IMS sends output messages to a VTAM programmable node and the node wants to stop receiving, the node signals IMS to stop transmissions after an end-of-chain has been sent. IMS does not send any more output to the terminal until the terminal sends the SNA release-quiesce (RELQ) command.

#### **Related Reading:**

- For more information on the quiesce-at-end-of-chain (QEC) function, see “Suspending Output from IMS” in *IMS Version 9: Customization Guide*. This state is only for Finance and SLU P terminals.
- For more information on ETO and user states, see “Setting Special Processing Modes” on page 178.

## Resource Status Recovery

Resource status recovery defines how a terminal or user is recovered. Recovery information can be shared using RM; therefore a resource can be recovered without using the IMS log records. In an IMS failure, a terminal or user can resume work without having affinity to the failed system or having to wait for IMS restart. You can also choose to recover resources only on a local system, or to delete the resource status.

This topic defines the resource status classifications and recovery modes. It then describes how recovery mode status is used with Fast Path and XRF.

## Understanding Terminal Modes and States

**Related Reading:** For detailed information about status recovery for specific resources, see “Status Recovery of TM Resources” on page 43.

### Resource Status Classification

IMS classifies resource status to determine how much information needs to be stored in the resource structure or in local log records.

#### Non-recoverable Status

Status only exists when the resource is active. Status is deleted when the resource becomes inactive and is not recovered at terminal logoff, user signoff, or IMS restart.

#### Recoverable Status

Status is recovered, but does not prevent the resource from being deleted across signoff, logoff, or IMS restart.

#### Significant Status

Status is recovered and the resource is not deleted across signoff, logoff, or IMS restart. Where the status is maintained depends on whether the status is command or end-user.

##### Command Significant Status

Status relates to the resource command, such as STOP, TRACE, and MFSTEST. Status recovery is always maintained globally by RM in the resource structure, if defined. Status is unaffected by status recovery mode. Not all statuses set by commands are significant. See “Status Recovery of TM Resources” on page 43 for details on specific commands.

##### End-User Significant Status

Status relates to resource work: conversation, STSN, and Fast Path. The status frequently changes, which can affect performance. Therefore, you can specify the status recovery mode as either GLOBAL, LOCAL, or NONE.

### Status Recovery Mode for End-User Significant Status

The status recovery mode defines the scope and location of recovery for resources with End-User Significant Status. You can set the default mode for each IMS, which is used for all resources unless overridden during a logon or signon. You can then set what End-User Significant Status to recover.

The following list describes how to set the status recovery modes for TM resources:

- Specify IMS defaults in DFSDCxxx.
- Modify user descriptors.

**Related Reading:** For more information about user descriptors, see “Creating User Descriptors” on page 165.

- Set the DFSLGNX0 override for static terminal logon and dynamic STSN terminal logon.
- Set DFSSGNX0 override for dynamic non-STSN user signon.

The following list describes the three recovery modes for End-User Significant Status.

#### GLOBAL Status Recovery Mode

All recoverable status is saved locally in the IMS record logs, but uses RM to recover the status instead of the logs. Status is restored at the next logon or signon and is available to any IMS in the IMSplex. When the resource

becomes active, status is copied to the local system. When the resource becomes inactive, status is deleted from the local system.

RM, a coupling facility resource structure, and shared queues are required. If you are sharing queues or have a resource structure, GLOBAL is the default. The default is overridden by DFSDCxxx, user descriptors, or logon and signon exit routines.

### LOCAL Status Recovery Mode

All recoverable status is saved locally in the local control blocks and log records. Status is restored at the next logon or signon and is only available to the same IMS that the user or node was accessing. Additionally, the user or node can only access the IMS where the local status is. This affinity is called *RM affinity*, which is enforced when End-User Significant Status exists. With RM affinity, IMS does not allow a terminal or user to log on to or sign on to an IMS if RM indicates that the user or terminal has RM affinity to another IMS. This affinity occurs because end-user significant status (conversation, STSN, or Fast Path) is being recovered on another IMS.

When the IMS with the RM affinity fails, the RM affinity still exists. The user or node can access another IMS immediately if the Logon exit routine (DFSLGNX0) or the Sign-on exit routine (DFSSGNX0) allows it, but resource status is not recovered and local status is deleted on the failed IMS at restart.

LOCAL is the default if a resource structure or shared queues are not used.

RM is not required. If RM is not active, RM affinity is not enforced.

### NONE Status Recovery Mode

No status is saved in RM or local log records. At logon or signon, significant status is cold. STSN, conversation, and fast path status is automatically non-recoverable.

RM and a resource structure are not required.

### Recoverability of Specific Resource Types

One way to specify the recoverability of specific resource statuses (conversation status, STSN status, and Fast Path status) is to use the following parameters in the DFSDCxxx PROCLIB member.

#### RCVYCONV= YES | NO

Specifies whether conversation status is recovered. This parameter does not affect output messages. If conversation status is not recovered, the output is still recovered and delivered asynchronously. YES is the default when SRMDEF=GLOBAL or LOCAL. NO is the default and YES is invalid when SRMDEF=NONE.

#### RCVYSTSN= YES | NO

Specifies whether STSN status is recovered for STSN terminals (SLU P, Finance, and ISC). This parameter affects only the recovery of STSN sequence numbers and does not affect output messages. YES is the default when SRMDEF=GLOBAL or LOCAL. NO is the default and YES is invalid when SRMDEF=NONE.

If you specify YES, then you must also specify that Fast Path status is recovered (RCVYFP=YES). See “Fast Path Recovery” on page 42 for more information.

## Understanding Terminal Modes and States

### RCVYFP= YES | NO

Specifies whether Fast Path status and Fast Path output are recovered. YES is the default when SRMDEF=GLOBAL or LOCAL. NO is the default and YES is invalid when SRMDEF=NONE.

You must specify YES if you specify that STSN status is recovered. See “Fast Path Recovery” for more information.

### Fast Path Recovery

Recovering Fast Path transactions depends on the status recovery mode, the Fast Path recovery, the STSN recovery, and where the Fast Path transaction runs. Table 4 lists the recovery and status of Fast Path transactions based on these criteria. If the transaction runs locally without going through the EMH queue, IMS cannot recover Fast Path status globally in RM. In the situation where the status recovery mode is GLOBAL but the transaction is running locally, the status recovery mode is temporarily changed to LOCAL with the terminal or user having RM affinity.

Table 4. Determining Fast Path Recoverability

Status Recovery Mode	Fast Path Recovery (RCVYFP)	STSN Recovery (RCVYSTSN)	Local Fast Path (DBFHAGU0)	Shared EMH Queues (DBFHAGU0)
LOCAL or GLOBAL	NO	NO	Status and messages discarded	Status and messages discarded
LOCAL or GLOBAL	NO	YES	INVALID	INVALID
LOCAL	YES	NO	Status and output recovered locally. STSN cold started.	Status and output recovered locally. STSN cold started.
GLOBAL	YES	NO	Status and output recovered locally. STSN cold started.	Status and output recovered globally. STSN cold started.
LOCAL	YES	YES	Status and output recovered locally. STSN recoverable.	Status and output recovered locally. STSN recoverable.
GLOBAL	YES	YES	Status and output recovered locally. STSN recoverable.	Status and output recovered globally. STSN recoverable.

### Recovery Modes for XRF Terminals

This topic describes how status recovery modes affect the terminal classes during an Extended Recovery Facility (XRF) takeover. Operating in an XRF environment does not affect status recovery modes. However, recovery of class-1 terminals is slightly different when using status recovery modes in a sysplex environment compared to a an environment not using RM.

**Related Reading:** For more information on planning for XRF and terminal classes, see “Planning for the Extended Recovery Facility (XRF)” on page 49.

**Class-1 Terminals:** IMS relies solely on local log records for an XRF takeover, even if the status recovery mode is GLOBAL. When session takeover is complete, IMS reconciles any differences in status between RM and the new active system. The GLOBAL mode provides the benefit of a user or terminal being able to log on to another IMS in the IMSplex following normal termination, but for class-1 terminals, LOCAL mode may be more appropriate.



**Class-2 Terminals:** IMS uses local log records during a takeover if status recovery mode is LOCAL and RM if status recovery mode is GLOBAL. The new active system logs active terminals on, but user signon is required. IMS uses local log records to initiate logon, but determines recovery based on the status recovery mode of the user or terminal.

**Class-3 Terminals:** IMS does not automatically take over these terminals. Recovery is based on the status recovery mode.

### Status Recovery of TM Resources

IMS saves recoverable statuses for LTERMs, nodes, users, and user IDs. This topic lists the statuses saved for each.

**LTERM Recovery Status:** IMS saves the following LTERM recoverable statuses:

- LTERM name
- EDIT=UC (upper case translation specification)
- Node or user owner

IMS saves the following LTERM command significant statuses:

- /ASSIGN SAVE
- STOP

**Node Recovery Status:** IMS saves the following recoverable statuses:

- Node name
- Device type
- Allocated LTERM name
- Allocated user name

IMS saves the following command significant statuses:

- EXCLUSIVE
- MFSTEST
- STOP
- TRACE

IMS saves the following end-user significant statuses:

- Conversation
- Fast Path
- STSN

**User Recovery Status:** IMS saves the following user recoverable statuses:

- User name
- User ID
- Allocated LTERM names
- Allocated node names
- Autologon parameters

IMS saves the following user command significant statuses:

- EXCLUSIVE
- MFSTEST
- STOP

## Understanding Terminal Modes and States

- /CHANGE AUTOLOGON SAVE

IMS saves the following user end-user significant statuses:

- Conversation
- Fast Path

**User ID Recoverable Status:** IMS saves the following LTERM recoverable statuses:

- User ID
- Terminal Name

---

## Planning for Security

To prevent unauthorized use of a terminal in the IMS network, you can use two types of security:

- RACF (or an equivalent product. RACF is a licensed program available under the z/OS operating system)
- IMS Security Maintenance Utility (SMU)

**Recommendation:** IMS Version 9 is the last version to support SMU. Therefore, you should use only RACF (or an equivalent product) for IMS security.

RACF and SMU allow you to control access to:

- Physical terminals
- Logical terminals
- Transactions
- Commands

If you do not use either of these security options, IMS allows only certain commands to be entered at user terminals (excluding the master terminal). This is called *default terminal security*.

**Related Reading:** For a list of commands that cannot be entered at user terminals, see *IMS Version 9: Command Reference*.

RACF and SMU provide two different ways to configure your IMS network security profiles:

- Using RACF, you can design security profiles based on user ID.
- Using SMU, you can design security profiles based on LTERM names.

You can define two levels of security for your network:

- You can control the use of the terminals connected to your network.
- You can control the resources that can be accessed from the terminal.

You control use of a terminal by signon verification security. For example, a terminal user enters an identifier as a parameter on a /SIGN command or in response to a DFS3649 message. You can use RACF, an exit routine, or both to validate the signon. The user ID is logged with each input and output message and with each database change.

The following topics describe the methods you can use to control access to resources from a terminal:

- “Authorizing Transactions In a TM Network”
- “Authorizing Commands In a TM Network”
- “Transaction Command Security” on page 46
- “Password Security” on page 46
- “Security for APPC/IMS” on page 47
- “Security for ETO” on page 47

### Authorizing Transactions In a TM Network

During transaction authorization, RACF or SMU checks to ensure that the terminal user or the LTERM is authorized to enter the transaction.

**Related Reading:** For more information on security for transactions, including the use of RACF and SMU, see *IMS Version 9: Administration Guide: System*.

#### Using RACF to Secure Transactions

To control which users can issue which transactions, define the controlled transactions to RACF as TIMS class, and grant authorization to RACF-defined users or groups of users.

You can also use System Monitoring Facility (SMF) logging to track the successes and failures of transaction authorization. Using RACF, request auditing capabilities for your transaction security profiles.

#### Using SMU LTERM Security to Secure Transactions

You can control which transactions a terminal can issue by defining the transactions that the terminal’s associated LTERM is authorized to issue. You enter these definitions as input to SMU. SMU stores the definitions in the IMS.MATRIX data set.

**Note:** IMS Version 9 is the last version of IMS to support SMU.

**Related Reading:** For more information on SMU, see *IMS Version 9: Utilities Reference: System*.

#### Using the Transaction Authorization Exit Routine (DFSCTRN0)

You can use the Transaction Authorization exit routine (DFSCTRN0) to check the validity of a transaction that is entered by a user who signed on using the /SIGN command. You can use the Transaction Authorization exit routine with both RACF and SMU.

**Related Reading:** For more information on using the Transaction Authorization exit routine (DFSCTRN0), see *IMS Version 9: Customization Guide*.

### Authorizing Commands In a TM Network

For command authorization, you can use RACF, the Command Authorization exit routine (DFSCCMD0), and SMU.

**Related Reading:** For more information on security for commands, including the use of RACF and SMU, see *IMS Version 9: Administration Guide: System*.

## Planning for Security

### Using RACF to Secure Commands

To control which users can issue controlled commands, define controlled commands to RACF as CIMS class, and grant authorization to RACF-defined users or groups of users.

You can use SMF logging to track the successes and failures of command authorization. Using RACF, request auditing capabilities for your command security profiles.

### Using SMU LTERM Security to Secure Commands

You can control the commands that a terminal can issue by defining the commands that the terminal's associated LTERM can issue. You enter these definitions as input to SMU. SMU stores the definitions in the IMS.MATRIX data set.

**Note:** IMS Version 9 is the last version of IMS to support SMU.

**Related Reading:** For more information on SMU, see *IMS Version 9: Utilities Reference: System*.

### Using the Command Authorization Exit Routine (DFSCCMD0)

You can use the Command Authorization exit routine (DFSCCMD0) to restrict keywords and parameters by editing the input command buffer. The Command Authorization exit routine checks the validity of commands. You can use this exit routine with both RACF and SMU.

**Related Reading:** For more information on using the Command Authorization exit routine (DFSCCMD0), see *IMS Version 9: Customization Guide*.

## Transaction Command Security

Transaction command security and password security provide another level of access control. Transaction command security is indirectly related to a terminal. If the terminal user enters a transaction to start a program that issues IMS commands, both the transaction code and the set of commands that program can issue must be authorized.

## Password Security

Password security requires that a transaction or a command that is entered at a terminal have a password. This allows you to implement secondary security to verify that the user who is issuing a specific transaction or command is authorized to do so.

### Using RACF and a Security Profile Based on User IDs

RACF provides the REVERIFY option, which requires the user's password to be entered when a command or a transaction is entered. You need to use RACF for signon authorization and include the REVERIFY parameter as APPLDATA when defining the transaction or command to RACF. You must specify RVFY=Y as an execution parameter in order to use REVERIFY.

### Using SMU and a Security Profile Based on LTERM Names

SMU's password security allows you to associate a password with controlled transactions and commands. Password security, if defined, is in addition to LTERM security.

## Security for APPC/IMS

APPC/IMS requires security using the System Authorization Facility (SAF) interface to RACF, or an equivalent security environment. RACF is optional for remote transactions from LU 6.2 application programs.

APPC/IMS supports both the Transaction Authorization exit routine (DFSCSTRN0) and the Command Authorization exit routine (DFSCCMD0).

### Restrictions:

- APPC/IMS does not support SMU security.
- APPC/IMS does not support the /SIGN command, because it is not required in order to validate the user ID. z/OS validates user IDs when using RACF; therefore, each APPC/IMS message has a validated user ID.
- For IMS commands entered from remote LU 6.2 application programs: if you do not use RACF or the Command Authorization exit routine (DFSCCMD0), the default command security allows only the following four commands:
  - /BROADCAST
  - /LOG
  - /RDISPLAY
  - /RMLIST

To allow other commands, use DFSCCMD0 or RACF.

**Related Reading:** For information on the AUTH call for APPC/IMS, see *IMS Version 9: Application Programming: Transaction Manager*.

## Security for ETO

If you use SMU security for static terminals and RACF security for ETO terminals, you might be in the position of having two security profiles:

- One based on the LTERM name
- One based on the user ID

You only need one security profile when using RACF security for command and transaction authorization on both static and ETO terminals.

**Restriction:** SMU does not support ETO terminals.

**Related Reading:** For more information on ETO security, see “Planning a High-Security Environment with ETO” on page 157.

---

## Planning for Fast Path Terminals

To have a Fast Path-capable system, specify Fast Path support on the FPCTRL macro. IMSs with a very high transaction rate use Fast Path’s expedited message handler (EMH) facility. EMH is a performance option that expedites message processing by imposing restrictions on message lengths and segmentation. LU 6.2 terminals can use EMH; no definitions or specifications are required.

With Fast Path, an EMH buffer is acquired from the EMH buffer pool when the first eligible input message is received for a Fast Path transaction. The buffer remains allocated to the terminal for future use until the session terminates or the

## Planning for Fast Path Terminals

user signs off. If an EMH buffer is allocated to the terminal, it is reused if it meets the requirements of the next input call. If the message requires a larger buffer, Fast Path swaps it for a larger one.

If, at entry to IMS, an input message satisfies all of the following criteria, it is edited in a Fast Path EMH buffer instead of in a full-function message queue buffer.

- Terminal is not FES capable
- Terminal is not the MTO
- Input is single segment
- Input is non-MFS edited
- Input is not an IMS command
- Execution of at least one Fast Path transaction is scheduled using Fast Path

**Exception:** If the message is not a Fast Path transaction, the message is moved to a full-function message queue buffer.

When a message with all of these characteristics is received, an EMH buffer is allocated to the terminal. The EMH buffer remains allocated to the terminal until either the user signs off or the session terminates. The buffer is used repeatedly for Fast Path transactions until a larger EMH buffer is required for special applications. When a larger buffer is needed, the current EMH buffer is swapped for the larger-size EMH buffer. The smaller EMH buffer is released and returned to the EMH pool.

The EMHL parameter in the IMS control region initialization (also known as the startup parameter) specifies the default EMH buffer size for all Fast Path transactions for all Fast Path-eligible terminals. A Fast Path transaction can specify an EMH buffer that is larger than the default. Specify larger application EMH buffer sizes on the APPLCTN or TRANSACT stage\_1 macros by using the FPATH=*size* parameter when you generate the system. If the EMH buffer pool is exhausted, message DFS3971 is sent to the input terminal.

Buffers are extracted from the EMH buffer pool, which expands and contracts dynamically. The size of the pool depends on the number of terminals that are concurrently entering Fast Path transactions and the buffer sizes that are required to satisfy each request.

You can say FPATH=No or Yes on the APPLCTN and TRANSACT macros, or you can specify FPATH=*size*, where *size* is the EMH buffer size that is required to run the transaction. FPATH=*size* implies FPATH=Yes. The minimum EMH buffer size is 12 bytes, and the maximum is 30720 bytes.

MSDBs are available to ETO terminals, unless they have terminal-related keys.

The OPTIONS keyword on the TERMINAL macro or ETO descriptor is used to:

- Declare FORCRESP or TRANRESP so that Fast Path-eligible terminals operate in response mode
- Specify PAGDEL for automatic page deletion where appropriate

You can use non-VTAM terminals to enter Fast Path transactions. For non-VTAM terminals, the LINE macro must indicate response mode by using the RESP=TERM parameter.

**Related Reading:** For information on the communication devices that are supported by Fast Path, see *IMS Version 9: Release Planning Guide*.

---

### Planning for the Extended Recovery Facility (XRF)

| An XRF complex enables you to rapidly resume end-user services when a failure  
| occurs. You can also use XRF to switch all transaction and database processing  
| from one IMS system to another for scheduled maintenance or during off-peak  
| periods.

When you do not use XRF, a high level of availability with short interruptions in end-user service can be difficult to achieve when IMS fails. Termination processing must complete, and the cause of the failure determined before restart can take place. A restart can be time-consuming if IMS regions must be restarted and terminal sessions reestablished.

An XRF configuration consists of a primary system, called the *active IMS*, and a secondary system, called the *alternate IMS*. The alternate IMS tracks the activities of the active IMS in the same or in a different central processing complex (CPC). The active IMS processes the IMS workload in the same way that it would without XRF. It does not do any additional processing or logging. Using the log, the active IMS informs the alternate IMS of its activities. Surveillance mechanisms alert the alternate IMS to problems in the active IMS. The active IMS is not aware of the activities of the alternate IMS.

The alternate IMS does not process any transactions; it maintains the status of the active IMS, and monitors it for any indications of trouble. The alternate IMS tracks resource changes in the active IMS, and updates its control blocks and buffers while continuously changing its status of readiness. In this manner, work can be quickly shifted from the active IMS to the alternate IMS without interruption. This shift of work from the active IMS to the alternate IMS is known as the takeover process. See Figure 8 on page 50 for an example of a simple XRF complex.

**Related Reading:** For more information on XRF, see *IMS Version 9: Administration Guide: System*.

## Extended Recovery Facility (XRF) and IMS

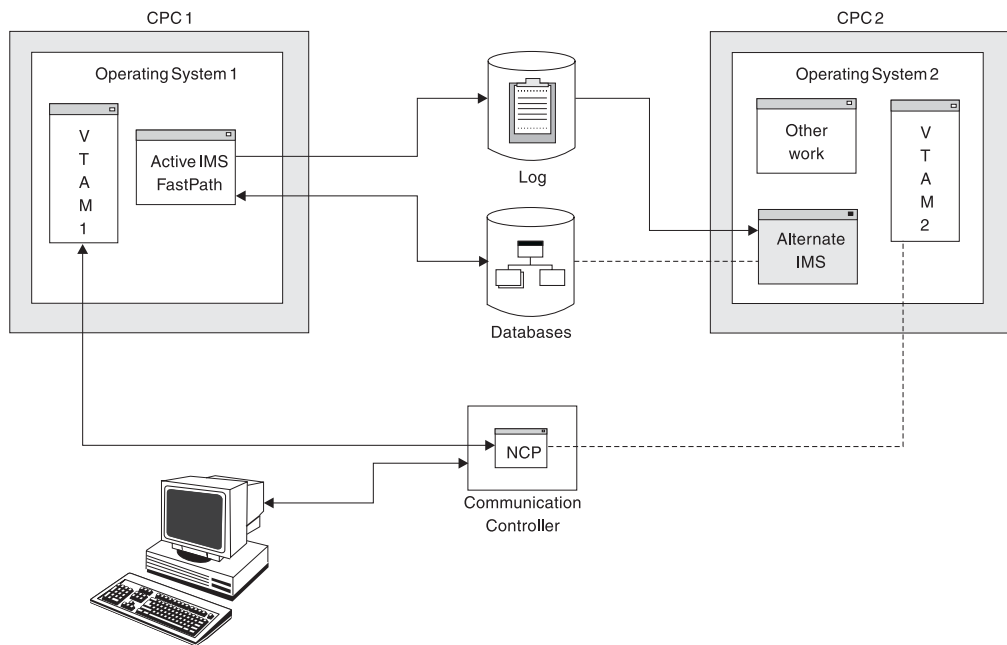

Figure 8. Sample XRF Complex

### Using MNPS or USERVAR In XRF Complexes

You can implement one of two types of XRF complexes:

- An XRF complex that uses VTAM multinode persistent sessions (MNPS) with an MNPS ACB.
- An XRF complex that uses a user variable (USERVAR) with USERVAR tables.

Both types of XRF complex provide the same increased availability for IMS, but differ in how they manage terminal sessions and the takeover process. Other differences include:

- XRF complexes that use a USERVAR have additional hardware requirements.
- VTAM and the network terminals use different names to communicate with IMS in each type of complex:
  - In an XRF complex that uses an MNPS, IMS is known to VTAM and the network terminals by the name of the MNPS ACB (the MNPS name).
  - In an XRF complex that uses a USERVAR, IMS is known to VTAM by the name of the APPLID ACB (the APPLID name) and to the network terminals by the USERVAR.

XRF complexes that use MNPS still have an APPLID ACB, but it is not used for the purposes of XRF.

**Related Reading:** For a complete discussion of XRF, see *IMS Version 9: Administration Guide: System*.

### Terminals in an XRF Complex

XRF supports all terminals that your IMS users are currently using. XRF provides emergency support with a minimum of effort from you. XRF requires that you specify keywords on several system definition macros or ETO descriptors. Unless



you want to change the switching priority of a terminal from the defaults, or to change the terminal type sessions, you need not change any terminal definition macros.

XRF automatically gives the terminals at your installation the best service that the terminal's characteristics allow. This topic describes these characteristics.

XRF provides support to the following three types of terminals:

- Class-1** At takeover, the sessions persist. The sessions are switched transparently to the alternate IMS without losing the session.
- Class-2** At takeover, the sessions end. The alternate IMS automatically tries to reestablish the sessions. The users are briefly without service.
- Class-3** At takeover, the sessions end. The operator or the end users can establish new sessions with the new active IMS if the terminals are physically connected to it.

Because APPC/IMS devices are Class 3, LU 6.2 conversations that are in progress at the time of failure are not preserved during a takeover. A new LU 6.2 conversation must be allocated from the new active IMS after a takeover occurs. The new active IMS processes APPC/IMS activity exactly the same as the old active IMS did prior to takeover. The new active IMS has the same LU name as the old active IMS.

**Related Reading:** For information about how status is recovered in an IMSplex, see "Recovery Modes for XRF Terminals" on page 42.

### Class-1 Terminals

To take full advantage of XRF, define most of the terminals in your complex as Class-1 terminals. Class-1 terminals are those terminals defined on the UNITYPE keyword of the TYPE macro as either:

- SLUTYPE1
- SLUTYPE2
- SLUTYPEP
- FINANCE

Class-1 terminals are handled differently depending on whether you use VTAM Multinode Persistent Session (MNPS) support. If you use MNPS, see "Class-1 Terminal Recovery in an XRF System With MNPS." If you do not use MNPS, see "Class-1 Terminal Recovery in an XRF System With USERVAR" on page 52.

**Class-1 Terminal Recovery in an XRF System With MNPS:** When you use XRF with MNPS, class-1 terminals do not have backup sessions on the alternate IMS. Instead, when a class-1 session is initiated in the active IMS, IMS tells VTAM to track both the session state and data traffic information.

During an XRF takeover, IMS requests that VTAM verify the class-1 terminal sessions and uses the data traffic information to transparently restore sessions. Higher priority terminals are restored before lower priority terminals.

The terminal types listed in Table 5 on page 53 are eligible for class-1 service if they are owned by an XRF-capable VTAM that is MNPS enabled. To enable VTAM for MNPS, specify PERSIST=MULTI on the APPL definition.

## Extended Recovery Facility (XRF) and IMS

**Class-1 Terminal Recovery in an XRF System With USERVAR:** In an XRF system with USERVAR, the alternate IMS maintains backup sessions for all class-1 terminals with open sessions on the active IMS. These sessions are established during the tracking phase when a session on the active IMS is initiated. In the event of a takeover, the alternate IMS switches all class-1 terminals to the backup sessions.

From the terminal user's point of view, only one session with IMS exists. From the NCP point of view, two host sessions exist. The actual messages are only passed between the node and the active IMS. The alternate IMS tracks the status of the message activity by monitoring the IMS log.

When the active IMS establishes or terminates a terminal session with class-1 terminals, the alternate IMS establishes or terminates its backup session with the terminal. When the active IMS fails, the alternate IMS takes over the terminal session (without losing control from the viewpoint of the node) by changing the mode of the established backup session from BACKUP to ACTIVE. When the session is switched, the NCP sends the new active IMS its view of the terminal's status. IMS compares this with its own status record to decide what, if any, recovery action to take. When the REVERIFY operand is used with RACF, the user must sign on again.

The terminal types listed in Table 5 on page 53 are eligible for class-1 service if they are both:

- Owned by an XRF-capable VTAM
- Connected to an XRF-capable NCP in a 37x5 Communication Controller

### Class-2 Terminals

Class-2 terminals do not have backup-session support on the alternate IMS, but they are restarted automatically by IMS after takeover.

When a Class-2 terminal session is established on the active IMS, the alternate IMS tracks the session initiation and termination by using log records. When the active IMS terminates abnormally, the alternate IMS tries to establish a new session with the network resources that were active before the failure.

When IMS tries to reestablish a session with a terminal that has no available network path, the attempt fails. Before IMS can reestablish a session on a locally attached terminal, the operator must switch the terminals to the new active IMS. If the complex has many of these kinds of terminals, you might consider giving the operator control before the takeover actually proceeds. At this time, the operator could perform the switch, allowing a faster recovery for sessions on these terminals. To give the operator this control, use the AUTO parameter in member DFSHSBxx in IMS.PROCLIB.

See Table 5 on page 53 for terminals that qualify as class-2.

If you have an application terminal that communicates with a programmable controller in an XRF complex, you might need to add code to the communications portion in order to achieve the highest level of transparency available. Additionally, for the ISC terminal, you must define a session for the link that connects the ISC terminal to an XRF IMS.

**Related Reading:** For information on the additional code required, see Chapter 12, "Overview of Intersystem Communication," on page 253 and *IMS Version 9: Customization Guide*.

### Class-3 Terminals

Class-3 terminals do not have backup session support on the alternate IMS. Their terminal sessions must be restarted manually on the new active IMS after takeover, either by the MTO or by user logon.

All IMS terminals are eligible for class-3 service. Class-1 and class-2 terminals that have indicated no switching should be done are eligible for class-3. This is done by specifying BACKUP=NO on the system definition macro or ETO logon descriptor.

Class -3 terminals use the existing procedures to connect with the new active IMS after takeover. If no path to the new IMSs exists, reestablishing the sessions might not be possible. All LU 6.2 conversations on the failing IMS must be reallocated after a takeover.

#### **Related Reading:**

- For more information on the BACKUP= keyword, search for BACKUP= in *IMS Version 9: Installation Volume 2: System Definition and Tailoring*.
- For more information on ETO logon descriptors, see “Coding ETO Descriptors” on page 160.

## Specifying Terminal Support

All terminals that IMS supports can be used in an XRF complex. The terminal characteristics determine the type of support a terminal can have in an XRF complex, with class-1 having the best support and class-3 having no support. Table 5 summarizes the keywords you can use to change the priority or terminal type of various devices.

*Table 5. Specifying Terminal Support*

Device	Class	BACKUP Keyword on TERMINAL Macro or ETO Logon Descriptor
SLUTYPE1 (3286) SLUTYPE2 (3278,3279,...) SLUTYPEP (4700,8100, SERIES 1,...) FINANCE 3601	Eligible for class 1,2,3	For class-1 service, BACKUP=(1-7,YES). For class-2 service, BACKUP=(1-7,NO). For class-3 service, BACKUP=NO.
LUTYPE6 (ISC) MSC (VTAM) NTO (leased line) 3270 (VTAM) SPOOL line groups BTAM (nonswitched line) 3270 (BTAM) Locally attached devices	Eligible for class 2,3	For class-2 service, BACKUP=(1-7,NO). For class-3 service, BACKUP=NO.
LU 6.2	Eligible for class 3	Not Applicable

The primary and the secondary master terminals are special types of terminals that exist simultaneously on both the active and alternate IMSs. They are not treated as class-1 or class-2 terminals. The master terminals on the alternate IMS are not disrupted by a takeover. After takeover, the master terminal on the alternate IMS processes the undelivered messages from the active IMS’s master terminal.

## Extended Recovery Facility (XRF) and IMS

The BACKUP keyword on several macros in the system definition statement or ETO logon descriptor specifies the actual support a terminal is to receive. Your installation determines the switching priority of the terminals, with level 1 being the lowest priority and level 7 the highest. Although IMS orders VTAM requests by priority, the requests might be completed in any order because of unpredictable factors in the network, such as pacing, line speeds, and congestion.

If BACKUP=(1-7,YES), the terminal is automatically taken over without losing session control. If the terminal is connected to an XRF-capable VTAM, this constitutes class-1 support.

For both class-1 and class-2 terminals, the default switching priority is 4.

If BACKUP=NO, this terminal must be restarted manually after takeover. This forces class-3 support.

If options on the BACKUP parameter are set incorrectly, IMS resets the incorrect option at session initialization. For example, if you specify BACKUP=(1-7,YES) for an ISC terminal, IMS will reset YES to NO because the highest class of support that an ISC terminal can receive is class-2.

### XRF with USERVAR and the BACKUP Parameter

For XRF systems with USERVAR, BACKUP=(1-7,YES) also tells the alternate IMS to maintain backup sessions for all class-1 terminals. The maximum number of terminal backup sessions that can be established on the alternate IMS is specified in the NCP BUILD statement with the BACKUP=n option. If the (n+1) class-1 terminal user tries to log onto the active IMS, the logon is denied.

If BACKUP=(1-7,NO), this terminal is automatically restarted after takeover, but no BACKUP session is established. This forces class-2 support.

---

## Planning for Rapid Network Reconnect (RNR)

Rapid Network Reconnect (RNR) automatically reconnects IMS VTAM terminal sessions across outages (IMS, z/OS, CPC, or VTAM) and subsequent IMS restarts on the same or another CPC within an IMSplex. The use of RNR can provide greater availability of VTAM sessions and eliminate the need for session cleanup and restart after an outage.

**Note:** This topic applies only to RNR systems and should not be confused with XRF systems, which also use VTAM multinode persistent sessions (MNPS).

## Specifying Levels of Support

RNR support can be specified at three levels:

- IMS execution parameters; or
- ETO logon descriptor OPTIONS= parameter; or
- By session using the Logon exit routine (DFSLGNX0)

RNR support is specified in the DFSDCxxx PROCLIB member by indicating RNR=ARNR, RNR=NRNR, or RNR=NONE. ARNR activates RNR and specifies that a basic session reconnect will be performed automatically by IMS during the /START DC process following an IMS or VTAM restart. NRNR specifies that automatic session reconnect will be activated, but not used unless overridden by the logon descriptor or the logon user exit routine. Unless overridden, the session will be terminated following restart of IMS or VTAM. NONE will not activate RNR at all.

If RNR is specified without a parameter (RNR= without ARNR or NRNR), NRNR is the default. If RNR is not specified at all (no RNR=), RNR will not be activated just as if RNR=NONE was specified.

RNR support can also be indicated on the ETO logon descriptor using the `OPTIONS= ARNR|NRNR` parameter. The RNR support specified at this level overrides that set at the system level using IMS execution parameters. If IMS was initialized with RNR unspecified, then specification of RNR support on the ETO logon descriptor is ignored.

RNR support can be indicated on the Logon exit routine (DFSLGNX0) using the `LGOPT=LGOARNR` parameter. The RNR support specified at this level overrides that set using the ETO logon descriptor or the system level execution parameters. If IMS was initialized with RNR unspecified, then specification of RNR support on DFSLGNX0 is ignored.

Using the DFSDCxxx PROCLIB member, you can also specify the maximum time for session persistence following an IMS or VTAM failure. The parameter for specifying this time is PSTIMER. PSTIMER can be set from 1 to 86400 seconds. The default setting is 3600 (1 hour). If 0 is indicated, then no timer is used and session persistence will continue indefinitely.

**Note:** If the VTAM START option for MNPS, HPRPST, is set to a lower value than PSTIMER, then VTAM START overrides the PSTIMER setting.

### Changing Levels of Support

RNR support can be turned on or off between sessions or between IMS restarts, and it can be changed at any level: in the IMS PROCLIB member, in the ETO logon descriptors, and in the Logon exit. Once RNR has been set on or off, it will not be applied until the next session cold start. For IMS terminals (non-ISC, Finance and SLUP), the result is that the last RNR option selected becomes active at each logon. For ISC, Finance, and SLUP terminals, the result is that the last RNR option selected spans multiple logons and IMS restarts and becomes active only at the next session cold start.

## Persistent Session Tracking

VTAM Persistent Session Tracking is provided for both single-node persistent sessions (SNPS), and multinode persistent sessions (MNPS). The level of VTAM persistent session support desired for IMS is specified on the APPL definition statement using the `PERSIST=MULTI|SINGLE` parameter.

VTAM SNPSs have the following characteristics:

- Reconnect must be on the same CPC as the original IMS.
- Only IMS failures and reconnects are supported.

VTAM MNPSs have the following characteristics:

- Reconnect may be on another CPC in an IMSplex.
- IMS, VTAM, z/OS, and CPC failures and reconnects are supported.

If you use VTAM MNPS, keep in mind that VTAM end nodes must be running in an APPN/HPR (High Performance Routing) network environment. In addition, all VTAMs must be connected to a Parallel Sysplex coupling facility using the ISTMNPS structure.

## Rapid Network Reconnect

APPC Persistent session support is provided by APPC/MVS. However, APPC conversations are not automatically restarted following an outage.

### Termination of Persistent Session Tracking

If a session terminates before IMS has closed the VTAM access control block (ACB), VTAM persistent session tracking, and IMS's ability to reconnect, are terminated on all terminals. An IMS-initiated shutdown could be executed, for example, by issuing the /CHECKPOINT FREEZE or /STOP DC or /CLSDST commands.

A VTAM session is also disconnected if VTAM persistent session tracking is prematurely terminated due to a non-IMS-initiated session close if that session close occurred before an IMS restart completion, which can happen for one of the following reasons:

- Remote operator-initiated session termination; executing, for example, the /RCL command
- Network operator-initiated session termination; executing, for example, the VARY NET or INACT commands
- Timeout of persistent session tracking indicated by the PSTIMER value

If IMS is defined for RNR on MNPS, the VTAM Network Operator can determine whether persistence is currently active by using the VTAM DISPLAY ID command.

When shutting down VTAM, the HALT NET or HALT NET, QUICK commands terminate session persistence, and the HALT NET, CANCEL command maintains session persistence.

## IMS Shutdown and RNR

When IMS is shut down using the MVS MODIFY command for IMS, RNR quickly terminates the IMS network, and VTAM persistence is retained. After the /START DC command is issued, IMS then automatically reconnects all sessions specified with ARNR that were still active at ABEND; sessions that were specified with NRNR are terminated.

When IMS is shut down using the /STOP DC command followed by the /CHECKPOINT command, VTAM terminals are disconnected for each session, resulting in no automatic session reconnect following an IMS restart.

## Using RNR with XRF or VGR

RNR is not supported on a system configured with XRF. Attempting to activate RNR on an XRF-configured system produces a warning message indicating that execution will continue with RNR disabled.

RNR can be used in conjunction with VGR; however, IMS support for RNR takes precedence over VGR support. If a /START DC command is entered during an IMS restart, and RNR=NRNR, then the session is terminated and VGR, if active, performs the appropriate level of affinity and terminal status management. If a /START DC command is entered during an IMS restart, and RNR=ARNR, then the session is scheduled for reconnection and a new session with another IMS cannot be established by invoking VGR. If IMS is cold-started, then all active VTAM sessions are terminated and all active VGR affinities and statuses are deleted.

**Restriction:** RNR does not support OTMA connections.

## Terminal Reconnect Protocols

The reconnect protocol used for terminals with RNR activated depends on the kind of work in progress and the types of terminals in use at the time of the outage. Table 6 shows the reconnect protocol used for each type of terminal following a session outage. All terminals are assumed to have RNR activated. If a session cannot be reconnected, error message DFS2050 or DFS2055 is sent to the Master Terminal Operator.

Table 6. Rapid Network Reconnect Protocols

Terminal Type	Connect Protocol	Terminal Subtype	Message Generated
SLU1	SNA CLEAR	<ul style="list-style-type: none"> <li>• Static sessions</li> <li>• ETO printers</li> </ul>	DFS3650 <sup>1</sup>
	SNA SDT		DFS3649
			ETO non-printers
SLU2	SNA CLEAR	Static sessions	DFS3650
	SNA SDT	Static sessions	DFS3649
NTO	SNA CLEAR	Static sessions	DFS3650
	SNA SDT	ETO sessions	DFS3649
SLU0	SNA UNBIND	Static sessions	DFS3650
(Non-SNA 3284 and 3286)	SNA BIND	ETO sessions	DFS3649
SLU0	SNA CLEAR	ETO sessions	No message
(Finance and SLUP) <sup>2</sup>	SNA STSN		
	SNA SDT		
ISC (Primary Half-Session)	SNA UNBIND		No message
	SNA BIND		
	SNA STSN		
	SNA SDT		
ISC	SNA UNBIND		No message
ETO w/ ALOT=0 <sup>3</sup>	UNBIND		No message
	UNBIND		

### Notes:

1. Message DFS3649 indicates that signon is required. Message DFS3650 indicates that no signon is required.
2. Reconnect is available only for Single-Node Persistent Sessions.
3. Signon data must be supplied as logon user data or by the DFS LGNX0 exit.

## Signon Security

Depending on whether RNR is activated or not and the types of terminals you are using, signons or logons of VTAM sessions may be required following IMS restarts. If RNR is not activated, then both logon and signon of sessions are required. If RNR is activated, then the following types of terminals require signon after a session reconnect:

- SLU0 (non-printer, 3270, non-SNA)

## Rapid Network Reconnect

- SLU1 (non-printer only)
- SLU2
- NTO

If RNR is activated, then the following types of terminals sign on automatically after a session reconnect:

- SLU0 (Finance/3600)
- SLU0 (SLUP)
- SLU1 (3284, 3286, non-SNA)
- ISC (LU 6.1)



---

## Chapter 3. Defining the Network

Performing a system definition for an IMS terminal network includes each of the following:

- Defining the names of the terminals
- Defining the terminal device types
- Specifying optional parameters, such as buffer sizes

The IMS network consists of static and dynamic terminals (ETO and LU 6.2 devices). You do not need to define your ETO or LU 6.2 devices to IMS.

Although only static terminals in the IMS network are defined by system definition macros, both static and dynamic terminals must be defined to VTAM. You must coordinate several aspects of the IMS requirements with parameters that are specified during VTAM network generation. This chapter highlights those coordination activities, but does not attempt to relate the separate IMS system definition in a detailed way with the series of VTAM and NCP definitions.

### **In this Chapter:**

- “Preparing for the Operational Network”
- “Coordinating IMS Definition and Network Definition” on page 60
- “Network Operation” on page 65
- “IMS Transaction Types and Transaction States” on page 66
- “Restarting the Network after Remote Takeover” on page 68
- “VTAM Definition for Transport Manager” on page 69
- “Defining VTAM for Rapid Network Reconnect (RNR)” on page 70

**Related Reading:** For an example of an IMS system definition, including definitions for various types of remote logical units see *IMS Version 9: Installation Volume 2: System Definition and Tailoring*.

---

## Preparing for the Operational Network

In establishing the network, you must incorporate the IMS system definition requirements into the corresponding VTAM generations. You should also track the overall progress and the hardware installation schedules. The principal activities involved in establishing the IMS network consist of:

- Gathering the IMS requirements for physical terminals.
  - In addition, gather the following information regarding terminal requirements:
    - Organize input data for stage-1 IMS system definition for static terminals.
    - Define ETO descriptors and display screen characteristics for dynamically allocated terminals.
    - Define LU 6.2 descriptors.
    - Use the terminal profiles as part of the documentation for the IMS system design.
- Matching the terminals that are specified for IMS with those available for wider use by the installation.

## Preparing for the Operational Network

Multiple users can exist on high-function terminals, and the terminals might not be dedicated to the IMS online system. You need to be able to identify these terminals to the network generation personnel and to identify expected usage by the end users.

- Matching IMS system definition parameters to their counterparts in network generation.

Correct device function might require the matching of IMS SYSGEN parameters with VTAM and NCP network parameters. Be especially careful when defining buffer sizes. IMS and network buffer sizes must be compatible. Although system definition in IMS for ETO and LU 6.2 devices are not necessary, you must define them to VTAM.

- Monitoring the hardware installation plan.

Create a plan for tracking the progress of hardware installation and network generation to ensure that the change to production mode is not jeopardized. This tracking might involve interacting with hardware specialists who install and maintain terminal hardware.

- Anticipating terminal installations.

You might want to predefine terminals to IMS in anticipation of their installation.

### Related Reading:

- For more information on signing on or logging on to terminals using user data, see Chapter 9, “Administering the Extended Terminal Option,” on page 147.
- For more information on signing on or logging on to terminals using user data, see Chapter 9, “Administering the Extended Terminal Option,” on page 147.
- For the information necessary to include APPC/IMS in your network, see Chapter 20, “Administering APPC/IMS and LU 6.2 Devices,” on page 405.

---

## Coordinating IMS Definition and Network Definition

Provide input to VTAM and NCP regarding the following network requirements:

- “Using IMS as a Host Subsystem”
- “Defining VTAM Nodes” on page 61
- “Estimating VTAM Storage Requirements” on page 61
- “Determining VTAM Buffer Pool Values” on page 61
- “Determining the NCP Buffer Pool Values” on page 62
- “Determining Static and Dynamic Terminal Signon Requirements” on page 62
- “Checking Requirements for LOGON MODE Tables” on page 63
- “Specifying Initial VTAM Configurations” on page 64
- “Using SON/COS Support in IMS” on page 64

### Using IMS as a Host Subsystem

You must define the IMS control region to VTAM as an application. Your installation needs to decide on a name. This name is used in the definition of application nodes that are added to the SYS1.VTAMLST system data set.

**Example:** The following is an example of a control region definition:

```
IMS APPL AUTH=(ACQ),PRTCT=password
```

This example shows that a password is required in order to start communication with the subsystem. Use the `PASSWD` keyword on the `COMM` macro to specify,

for IMS system definition, the corresponding password. If the VTAM definition does not use IMS as the name for the IMS subsystem, code the chosen subsystem name in the COMM macro for IMS, using the APPLID keyword. The default APPLID name is IMS.

### Defining VTAM Nodes

The local node names are also added into SYS1.VTAMLST. You need to take special care that the exact terminal names used in the IMS system definition are repeated in the local list members of that data set. Other characteristics of the terminal are specified in the VTAM entries, and you must ensure that no inconsistencies exist between IMS and VTAM parameters. Associated with the node name are:

- The use of program function keys or selector pen
- Keyboard characteristics
- Screen sizes
- Model number
- LU type
- Transmission service level

IMS verifies screen size, model, LU type, and transmission service for dynamic terminals. If these are not correct, a session is not established.

**Recommendation:** If you are a DC administrator, assure that the VTAM definitions are correct. These definitions are used to select ETO descriptors and MFS format characteristics. IMS system definition sets these definitions for static terminals and ignores VTAM definitions.

**Related Reading:** For more information on defining VTAM nodes, see “Identifying VTAM Device Types, Screen Sizes, and Models” on page 152.

### Estimating VTAM Storage Requirements

Examine the full set of terminal options that are planned for the IMS network and select those communication options that might have an effect on the VTAM storage requirements. For example, choose the appropriate:

- Protocol (BID or NOBID)
- Type of response patterns
- Number of active nodes

Using your terminal profiles, you can respond to the need for system programming information to estimate storage requirements for IMS support.

### Determining VTAM Buffer Pool Values

Provide the VTAM system programmer with IMS input and output message sizes. The values you select for the number and size of receive-any buffers, as specified on the RECANY keyword of the COMM macro, are of special importance. You must specify the largest number of receive-any buffers that are required in order to support the VTAM network. You can override the size with the execution parameter, RECASZ, and the number with the execution parameter, RECANY. Session initiation fails for terminals that are added to the system if they require a

## Coordinating IMS Definition and Network Definition

larger receive-any buffer size than the size that is currently specified. You must restart the IMS system, specifying the increased buffer size, before the terminal can establish a session with IMS.

### Determining the NCP Buffer Pool Values

Work with the system programmer to assess the volume of predicted traffic for application programs. The NCP buffer pool sizes and thresholds are based on the VTAM buffer pool information. No specific IMS requirements exist for NCP system definition parameters.

### Determining Static and Dynamic Terminal Signon Requirements

All VTAM-defined terminals can sign on by providing user data with the session initiation request, regardless of whether signon is required for the terminal.

You cannot sign on a user to more than one terminal simultaneously, unless you specify SGN=G, M, or Z on the EXEC parameter to allow multiple signons. Otherwise, IMS issues message DFS3649 or DFS2467.

A user cannot enter signon data from an output-only device through logon or a /SIGN command. When signon data is omitted at session initiation for an output-only device that requires a signon, message DFS2085 is sent to the MTO.

#### Multiple Signons

You cannot use the same name for dynamic LTERMs as for static LTERMs that are defined during system definition.

You can allow users to sign on concurrently to one or more terminals, static or dynamic, by specifying SGN=M in either the IMS or DCC procedures.

**Related Reading:** For more information about dynamic terminals, see “Signing On Multiple Times” on page 175.

The IMS master terminal receives a security violation message, DFS286, for rejected signon attempts. If you do not want to receive the message, set SECCNT to 0 on the COMM, MSGEN, or SECURITY macro.

**Related Reading:** For more information on disabling security violation messages, see *IMS Version 9: Customization Guide*.

#### Session Status Message—DFS3650

When signon is achieved or if signon is not required, message DFS3650 is sent to the user indicating the status of the session with IMS.

**Exception:** The following terminals do not receive these messages:

- Autologon terminals
- SLU-1 terminals running in unattended mode
- ISC
- SLU P
- 3600/Finance

In addition, if NOTERM is specified on the TERMINAL macro or on the ETO user descriptor, no DFS3650 message is received.

## Coordinating IMS Definition and Network Definition

**Related Reading:** For more information about when message DFS3650 is issued, see *IMS Version 9: Messages and Codes, Volume 2*.

The information presented on the DFS3650 message panel shows whether the user is in conversation mode. This status panel also shows whether user output security exists for the terminal.

### Checking Requirements for LOGON MODE Tables

When a static VTAM terminal is connected to IMS and a session is initiated, VTAM needs to know the LOGON MODE identifier. A table, the LOGON MODE table, exists in VTAM; it contains the SNA bind parameters for the session and the identifier (the LOGMODE parameter value, which is used at logon) for that terminal. Also, a default identifier for each SDLC-connected terminal exists.

These considerations apply to static VTAM terminals.

**Related Reading:** For more information on dynamic VTAM terminals, see “Identifying VTAM Device Types, Screen Sizes, and Models” on page 152.

### Coordinating LOGON MODE Identifiers

When you are deciding on the LOGON MODE identifiers, you need to:

- Match the naming conventions that are being used for the VTAM network in your installation. Your choice of a name might need to follow this convention.
- Arrange for automatic starting of IMS-remote terminals, or have them controlled by the VTAM operator. Otherwise, choose names that are meaningful to a remote terminal operator, if in order to initiate a session the remote terminal operator (RTO) enters the VTAM LOGON command.
- Choose names that are helpful to the master terminal operator if sessions are to be started with the /OPNDST command. If a terminal can be operated with different SNA protocols, the name should help distinguish between the operating modes.
- Use the MODETAB keyword on the TERMINAL macro or ETO logon descriptor to specify the default identifier that is to be used in the following situations:
  - The default identifier is not used.
  - The terminal operator does not specify the identifier in the LOGON command.
  - The master terminal operator does not specify the identifier in the /OPNDST command.

**Examples:** The code below illustrates the nature of the LOGON MODE table entries that are described to VTAM for a 3270 SDLC connection or a 4730 device. IMS defines these as SLU 2 and SLU P respectively.

```
SE3270  MODETAB
IBMS3270  MODEENT LOGMODE=S3270,FMPROF=X'02',TSPROF=X'02',      X
          PRIPROT=X'71',SECPROT=X'40',COMPROT=X'2000'
MT4730  MODEENT LOGMODE=MT4730,FMPROF=X'04',TSPROF=X'04',      X
          PRIPROT=X'B1',SECPROT=X'B1',COMPROT=X'6080',          X
          RUSIZES=X'0000'
MODEEND
```

The operator can enter either the VTAM LOGON command or use the VTAM USSTAB command for installation-determined logon syntax.

**Example:** The following example specifies a KEYWORD=*value* format:

## Coordinating IMS Definition and Network Definition

```
U3270 USSTAB
      USSCMD      CMD=IMS,REP=LOGON
      USSPARM     PARM=APPLID,DEF=IMS
      USSEND
      END
```

### Logon Requirements for the Master Terminal

Because IMS automatically logs on the master terminal after the IMS START command is issued, you must code the MODETBL keyword on the LU statement for the physical device that is used as the MTO if the VTAM default is not to be used.

When the MTO is using the /OPNDST command, a MODE operand applies to all node names presented in the command.

## Specifying Initial VTAM Configurations

Based on your IMS requirements, start lists (ATCSTRyy) and configuration members (ATCCONxx) are placed in the SYS1.VTAMLST library. This information should reflect those terminals that are to be activated at VTAM startup, and those VTAM nodes that are known to VTAM at startup. For ISC (LU 6) devices and MSC VTAM links, if the session is started from another subsystem, the session is not automatically recovered. Session failure messages are sent to the MTO indicating that you must manually restart the session.

You should emphasize flexibility in the IMS requirements, and try to reduce the requirements for a large part of the network to be immediately available. This might entail more elaborate startup instructions for start lists and configuration members. This might also be reflected in your MTO instructions and the extent to which the /OPNDST command is used. The delayed start up of network sections can overlap with IMS processing in order to allow IMS to start up more quickly. Also, the network startup sequence can be executed by an automated operator program executing in IMS.

## Using SON/COS Support in IMS

Session outage notification (SON) and class of service (COS) are facilities of VTAM and SNA that allow IMS to recognize a session outage. IMS attempts to restart the session for recoverable session failures. Both SON and COS must be specified in VTAM to be available for IMS use. In addition, the ASR option must be specified for the IMS node using the IMS SYSDEF or the /CHANGE command.

**Related Reading:** For more information on using the /CHANGE command, see *IMS Version 9: Installation Volume 2: System Definition and Tailoring*.

The IMS SON and COS support are available for all the VTAM SNA terminals and MSC VTAM links. When multiple virtual routes exist between IMS and the other LU, use an alternate route to avoid a network outage.

The SON facility enables VTAM to inform IMS that a session failure has occurred. The SON facility gives installations the option of allowing IMS to automatically restart sessions (without end-user intervention) if a recoverable session failure occurs in the network.

You need to code SONSCIP=YES on the VTAM APPL definition statement for the IMS application in order to activate automatic session restart after a session outage. If you decide not to include the SONSCIP definition for IMS, VTAM and IMS proceed with session termination without automatic session restart.

The COS facility allows VTAM to control selection of actual routes by designating a set of virtual communication routes based on speed of traffic, data type, and security considerations. These sets of routes are defined in the VTAM COS table. The mode table entry that is used for session establishment can specify a COS entry name.

When the set of session BIND parameters associated with the terminal contains a COS name, these specified virtual routes are scanned to determine which one can be used for the session. If the selected virtual route fails, restart of the session causes the COS set to be scanned again for use of a different virtual route for session reestablishment.

For program LUs (as well as Finance, LU P, MSC, and ISC), in-flight messages can be recovered and retransmitted as necessary, thereby preserving the integrity of the message exchange across the restart.

For device LUs, in-flight messages might be lost or duplicated.

SON and COS support preserves the session setup options (BIND parameters), as well as the class of service associated with the failing session by using the same mode table entry name in order to reestablish a new session.

**Restrictions:** Because the boundary node NCP cannot distinguish an upstream route failure from a failure of a host CPC, SON and COS support cannot be used for terminals in XRF configurations that have backup sessions.

---

## Network Operation

The following topics explain how to start an IMS network and how to initiate a session:

- “Starting an IMS Network”
- “Session Initiation” on page 66

### Starting an IMS Network

Before a session with IMS can be established, VTAM and NCP must be active.

To make IMS ready to receive VTAM logon (session initialization) requests, use the IMS /START command with the DC keyword. The /START DC command tells VTAM to pass to IMS any queued VTAM logon requests to IMS, as well as logon requests for any logical unit that is defined to VTAM as belonging to IMS.

The /START DC command activates the following processes:

- Initiates IMS data communication processing
- Opens the VTAM access method control block
- Enables the IMS VTAM Logon exit routine

Any logon requests VTAM receives before the IMS /START DC command but after the IMS VTAM access method control block (ACB) has been opened are queued in VTAM until the /START DC command is completed. If VTAM is active when IMS is initialized, the IMS VTAM ACB is opened. If VACBOPN=DELAY has been specified, then the VTAM ACB open is delayed until the /START DC command is entered.

Use the /START APPC command to start APPC/IMS.

### Session Initiation

**Definition:** A *session* is the logical connection between a logical unit (such as a terminal) and a VTAM application program (such as IMS). A session must be established before data can be transmitted between a logical unit and IMS.

Session initiation is requested in one of five ways:

- The terminal operator enters the LOGON sequence. VTAM verifies the command and passes the request to IMS.

The terminal operator can identify IMS in the logon sequence with the following names:

- The APPLID name, if the terminal operator is requesting a session with a specific IMS.
  - The MNPS ACB name, if the terminal operator is requesting a session with an XRF with MNPS system.
  - The USERVAR, if the terminal operator is requesting a session with an XRF with USERVAR system.
  - The generic resource name, if the terminal operator is requesting a session with a generic resource group.
- The z/OS VTAM network operator requests session initiation on behalf of the logical unit by using the VTAM VARY command with the LOGON option. VTAM processes the request and passes it to IMS.
  - VTAM passes a logon request to IMS for each logical unit that is defined to VTAM as belonging to IMS.
  - The IMS master terminal operator requests session initiation for a logical unit by entering the IMS /OPNDST command.
  - ETO autologon initiates the session and supplies the appropriate user data, based on user descriptors and exit routines.

**Related Reading:** For more information on logging on to your terminal and sharing printers, see “Logging onto ETO Terminals” on page 173 and “Sharing Printers Using ETO” on page 181.

For LU 6.2, session initiation occurs automatically as conversations are allocated. The IMS MTO can request delivery of queued LU 6.2 output by issuing the /ALLOCATE command. When using LU 6.2, remember that the IMS application name (which matches the LU name) for LU 6.2 conversations is different than the LU name IMS has for non-LU 6.2 types, and that the /START DC and /START APPC commands work independently.

Regardless of how session initiation is requested, identical processing occurs when IMS receives the request.

---

## IMS Transaction Types and Transaction States

This topic describes transaction types and transaction states.

### Defining IMS Transaction Types

Transactions are the most common type of data that is sent from a logical unit to IMS. IMS supports two kinds of transactions—update and inquiry.

**Definitions:**

- An *update* transaction can modify a database.



- An *inquiry* transaction can look at data in a database, but it cannot change or update it.

You define transactions as update or inquiry during IMS system definition.

An additional attribute is defined for inquiry transactions—recoverable or irrecoverable.

### **Definitions:**

- *Recoverable-inquiry transactions* are always recoverable, regardless of which element in the network fails.
- *Irrecoverable-inquiry transactions* are not recovered after an I/O error condition occurs or at IMS system restart.

All update transactions are recoverable. All Fast Path transactions must be defined as recoverable, but they can be either inquiry or update.

An LU 6.2 transaction is recoverable only if the asynchronous protocol is used to initiate the transaction. IMS conversational transactions from LU 6.2 programs are not recoverable in the local system, but they are recoverable across the MSC link.

IMS treats a irrecoverable transaction in the same manner as a recoverable transaction, except that all processing that required to achieve recoverability is eliminated.

As a result, irrecoverable transactions require less processing time, but they could be lost in the event of a network failure (for example, line failure, CPC failure, or queue failure).

## Determining Transaction States

The possible transaction states are:

**LOCK** A transaction in LOCK state does not receive messages. Scheduled messages containing this transaction code are stopped.

**Restriction:** The /LOCK TRANSACTION command cannot be used with Fast Path-exclusive transactions, but it can be used with Fast Path-potential transactions.

### **MODSTOPPED**

A transaction in MODSTOPPED state cannot receive input, because online change processing is in progress. A /MODIFY COMMIT command sets this status. A CPI Communications driven transaction cannot be marked MODSTOPPED.

**PSTOP** A transaction in PSTOP state cannot be scheduled; however, the transaction continues to be processed until the limit count is reached. If the limit count is large, the processing interval is long. To ascertain the status of the transaction, use the /DISPLAY command; to alter the status of the transaction, use the /ASSIGN command.

**PURGE** A transaction in a PURGE state has had its input messages stopped.

**QSTOP** A transaction in QSTOP state cannot be entered during the time between the completion of a /MODIFY PREPARE command and the completion of the corresponding /MODIFY COMMIT or /MODIFY ABORT

## IMS Transaction Types and Transaction States

command. Transactions that are known to be affected by the content of an online change are rejected; that is, the transactions are to be changed or deleted, or they could access databases or programs that are to be changed or deleted. By using the /DISPLAY MODIFY command, you can cause a list of transactions that are affected by a current online change to be displayed. At the terminal, such a transaction is rejected with message DFS3470. If the transaction uses a Fast Path routing code that is changed or deleted, the rejection message is DFS3471. A CPI Communications driven transaction is never in a QSTOP state.

- STOP** A transaction in STOP state is stopped. The queuing and scheduling of messages that are destined for a transaction or class of transactions are stopped. However, output can still be queued if it originates from an application program.
- USTOPPED** USTOPPED is a status value that is set when an application program attempts to use an IMS DL/I database resource that is not available, and the program terminates abnormally with abend U3033. The USTOPPED condition is not set for a CPI Communications driven program. The CPI Communications driven application program is abnormally terminated with an abend U0125.

---

## Restarting the Network after Remote Takeover

Unlike XRF, which automatically reestablishes data communications with class-1 and class-2 terminals, RSR remote takeover requires that you be involved in restarting the terminal network at the new active site. Your new active site (the old tracking site) should already have a proper system definition, including all ETO descriptors, terminal definitions specified in the TERMINAL macro, and all necessary VTAM definitions. Then, after remote takeover, you must restart the terminal network.

Before starting non-VTAM terminals, you need to physically switch all telecommunication lines and terminals to the new active subsystem. Because all non-STSN terminals have no knowledge of their work that was done immediately prior to the remote takeover, you receive no indications at the terminal or from IMS whether the remote takeover causes message data to be lost.

VTAM terminals must be disconnected from the old active site before they can log on to the new active subsystems at the new active site.

Finance terminals, SLU-P terminals, ISC terminals, and MSC links can cause IMS to recognize a lost-data condition after a remote takeover. If IMS recognizes this condition, the session resynchronization attempt fails, the MTO is notified, and IMS automatically forces the session or the MSC link to be cold started. Data loss is not recognized if information about the terminal's initial (cold start) logon is also lost. If IMS does not know the terminal was active at the old active site, it cold starts the session at the next logon. The terminal itself can recognize this action and issue messages (DFS2948 in a non-MSC environment, or DFS3311 and DFS3212 in an MSC environment), which you should save for possible manual resynchronization (recovery). From the messages and an associated CVCT log record, you can determine which input and output messages were lost, resulting in the resynchronization error.

**Related Reading:** For information on determining message loss following an RSR takeover, see *IMS Version 9: Diagnosis Guide and Reference*.

An IMS ISC remote primary half session can detect an STSN problem from the RSR secondary half session after remote takeover, but it cannot perform the automatic forced session cold start. The remote primary half session terminates with a DFS2050 message, and the MTO must manually force a session cold start using the following commands:

- /STO NODE *node* USER *user*
- /ASSIGN USER *user* TO VTAMPOOL
- /STA NODE *node*

VTAM MSC links can also be out of synchronization after a remote takeover if link cold start is not automated. The links and their sessions can be resynchronized in the same way as for unrecoverable data transmission errors when using VTAM in a non-RSR environment:

- Stop the link using the /PSTOP command.
- Change the link using the /CHANGE command (SYNCSESS to FORCSESS).
- Restart the link using the /RSTART command, thus forcing a session cold start.

MTM and CTC links cannot be restarted if significant data is lost, if the sessions are out of synchronization, and if the new active subsystem requires a cold start. If automatic restart fails for SLU-P or Finance devices, you must cold start IMS.

---

## VTAM Definition for Transport Manager

To use the IMS transport manager, some VTAM definitions are required, such as APPL definition and mode table definition.

### **Related Reading:**

- For information on VTAM definitions, see *IMS Version 9: Installation Volume 2: System Definition and Tailoring*.
- For specific information on VTAM definitions, see the appropriate VTAM publications.

## VTAM Buffering and Pacing

When VTAM runs out of buffers, it returns errors to SEND operations, which result in transport manager deallocation. In other words, if pacing causes VTAM to stop accepting data and the transport manager buffers for the conversation fill up, log data transport is temporarily suspended. To avoid this transport manager deallocation, use pacing (APPL VPACING=) and allocate enough VTAM IOBUFs to support a number of bytes of data equal to:

$$\text{VPACING} \times \text{log\_block\_size}$$

If session pacing is not used, a high-volume component (such as the IMS logger or IMS isolated log sender) will probably consume buffers faster than VTAM can empty them.

## VTAM Missing Interrupt Handler

You must be sure to include VTAM Missing Interrupt Handler (MIH) coding in the appropriate VTAM and z/OS definitions. If you do not include MIH in these definitions, and if the CTC link becomes inoperative, MIH continues to appear

## VTAM Definition for Transport Manager

active but is likely to be hung or unusable. And if the CTC link is inoperative, the transport manager subsystem is likewise inoperative.

---

### Defining VTAM for Rapid Network Reconnect (RNR)

To use Rapid Network Reconnect (RNR) for VTAM sessions, you must complete the following configuration tasks:

- Define VTAM for the level of persistent session support desired using the APPL statement for IMS.
- Assess user security requirements and exposures and define an appropriate level of RNR support for terminals.

**Related Reading:** For a more detailed description of Rapid Network Reconnect, see Chapter 2, “Planning the Network,” on page 23.

### Defining the Level of Persistent Support

VTAM Persistent Session Tracking is provided for both single-node persistent sessions (SNPS), and multinode persistent sessions (MNPS). You must indicate which level of persistent support is needed for RNR. MNPS allows VTAM sessions to be reconnected to another CPC in a sysplex, if necessary. SNPS requires that VTAM sessions be reconnected to the same CPC they were connected to when the outage occurred.

The level of VTAM persistent session support desired for IMS is specified on the APPL definition statement using the PERSIST=MULTI|SINGLE parameter. The default setting is PERSIST=SINGLE. If no PERSIST specification is entered, PERSIST=SINGLE is assumed.

### Defining the Level of RNR Support

RNR support can be defined at three levels: the system level, the terminal level, and the session level. To use all three levels of control over RNR support, you must:

- Update the IMS execution parameters to activate RNR.
- Update the appropriate IMS ETO Logon descriptors for dynamic terminal support.
- Update the DFSLGNX0 Logon exit support for dynamic override of the RNR option on a session by session basis.

To activate RNR at the system (and default) level, you must specify in the DFSDCxxx IMS.PROCLIB member whether to activate RNR by indicating either RNR=ARNR (Activate RNR) or RNR=NRNR (No RNR).

Using the PSTIMER parameter in the DFSDCxxx IMS.PROCLIB member, you can also specify the maximum time for session persistence following an IMS or VTAM failure. PSTIMER can be set from 1 to 86400 seconds. The default setting is 3600 (1 hour). If 0 is indicated, then no timer is used and session persistence continues indefinitely.

**Note:** If the VTAM START option for MNPS, HPRPST, is set to a lower value than PSTIMER, it overrides the PSTIMER setting.

To control RNR support for ETO dynamic terminals, use the OPTIONS= ARNR|NRNR parameter in the ETO logon descriptor. The RNR support specified at this level overrides that set at the system level using IMS execution parameters.

## Defining VTAM for Rapid Network Reconnect

To control RNR support on a session by session basis, use the LGOPT=LGOARNR|LGONRNR parameter for the Logon exit routine (DFSLGNX0). The RNR support specified at this level overrides that set using the ETO logon descriptor or the system level execution parameters.

The parameters of DFSLGNX0 are documented in its source code.



---

## Chapter 4. Editing and Formatting Messages

IMS uses two methods to edit and format messages to and from terminals: Message Format Service (MFS) and basic edit routines. IMS also provides routines to edit:

- Input and output from a terminal
- Transaction codes
- Input message fields
- Input message segments
- Message switching

This chapter presents an overview of the advantages of MFS, introduces MFS control blocks for message formatting, and summarizes the characteristics of the different devices MFS supports and the responsibilities of the MFS administrator.

**Restriction:** MFS does not support LU 6.2 devices. DFSLUEE0, an Edit exit routine, is provided for both input and output messages from LU 6.2 devices when the implicit API support is used.

**Related Reading:** For guidelines in coding the Edit exit routine, see *IMS Version 9: Customization Guide*.

### **In this Chapter:**

- “Message Format Service”
- “Creating MFS Formats with SDF II” on page 81
- “Basic Edit” on page 83
- “IMS Editing for Intersystem Communication (ISC)” on page 84
- “Transparency Option” on page 85
- “Unprotected Screen Option” on page 86
- “Bypassing MFS Editing” on page 86
- “IMS Sensitivity to Nongraphic Message Data” on page 86
- “Controlling Output Devices” on page 88
- “Small Buffer Devices” on page 89
- “Controlling Output” on page 89

---

## Message Format Service

Message Format Service (MFS) is an IMS facility that formats messages to and from terminals, so that IMS application programs need not deal with device-specific characteristics in input or output messages.

MFS formats messages to and from user-written programs in remote controllers and subsystems, so that host application programs need not deal with terminal-specific characteristics of the remote controller.

MFS uses control blocks that the user specifies to indicate to IMS how input and output messages are arranged.

## Message Format Service

- For input messages, MFS control blocks define how the message that is sent by the device to the application program is arranged in the program's I/O area.
- For output messages, MFS control blocks define how the message that is sent by the application program to the device is arranged on the screen or at the printer. Data, such as literals that appear on the screen but not in the program's I/O area, can also be defined.

In IMS systems, data that is passed between the application program and terminals or remote programs can be edited by MFS or basic edit. The facilities provided by MFS depend on the type of terminals or secondary logical units (SLUs) your network uses.

MFS allows application programmers to deal with logical messages instead of device-dependent data; this simplifies application development. The same application program can deal with different device types using a single set of logic, whereas device input and output are varied for a specific device type. The presentation of data on the device or operator input can be changed without changing the application program. Full paging capability is provided by IMS for display devices. Input messages are created from multiple screens of data.

A program using MFS need not be designed for the physical characteristics of the device that is used for input and output messages unless it uses very specific device features. Even when these features are used, the program can request that MFS assist in their presentation to the program or the device.

MFS supports SLU-type devices SLU-1, SLU-2, SLU-P, Finance, and LU 6.1. MFS also supports older devices, including IBM 2740, 2741, 3270, and 3600.

For IBM 3270 or SLU-2 devices, device control characters or orders can be sent directly from or received by the program using the MFS bypass function. This gives the application program more direct control of the data stream. The program uses reserved format names that cause MFS to bypass the edit of:

- the output message
- the next input message that is received from the display terminal

Both logical- and physical-paging facilities are provided for the IBM 3270 and 3604 display stations; these facilities allow the application program to write large quantities of data that MFS can divide into multiple display screens on the terminal. The terminal operator has the capability to page forward and backward to different screens within the message.

## MFS Components

MFS has several components:

- MFS Language utility
- Message editor
- MFS pool manager
- MFS Service utility
- MFSTEST pool manager
- MFSDCT utility (DFSUTB00)

The MFS Language utility is executed offline to generate control blocks and place them in a format control block data set named IMS.FORMAT. The control blocks



describe the message formatting that is to take place during message input or output operations. They are generated according to a set of utility control statements.

Figure 9 shows an overview of the MFS utilities and their output. For details on these utilities, see *IMS Version 9: Utilities Reference: Database and Transaction Manager*.

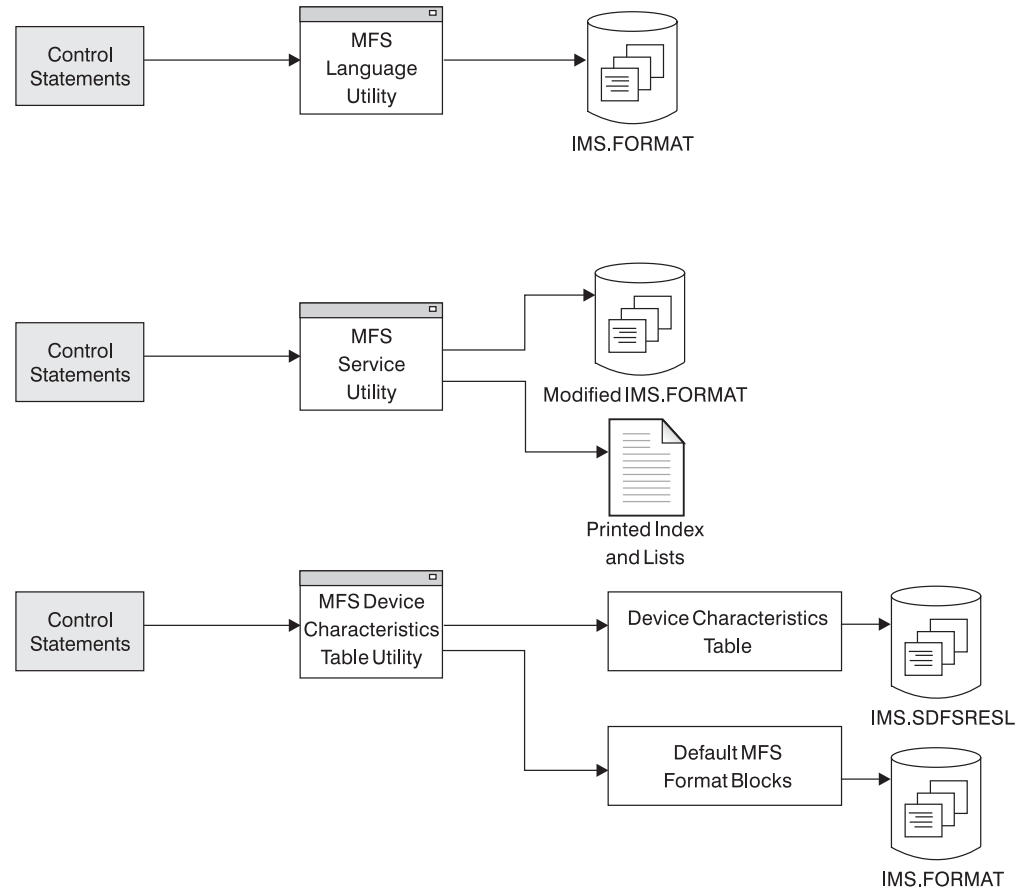

Figure 9. MFS Utilities and Their Output

**Note:** In MFS test mode, the MFS Language utility can run at same time as the online IMS control region. However, you must use the online change procedure to modify MFS formats when not in IMS test mode.

Figure 10 on page 76 shows the MFS online environment. The steps listed following the figure correspond to the numbers in the figure.

## Message Format Service

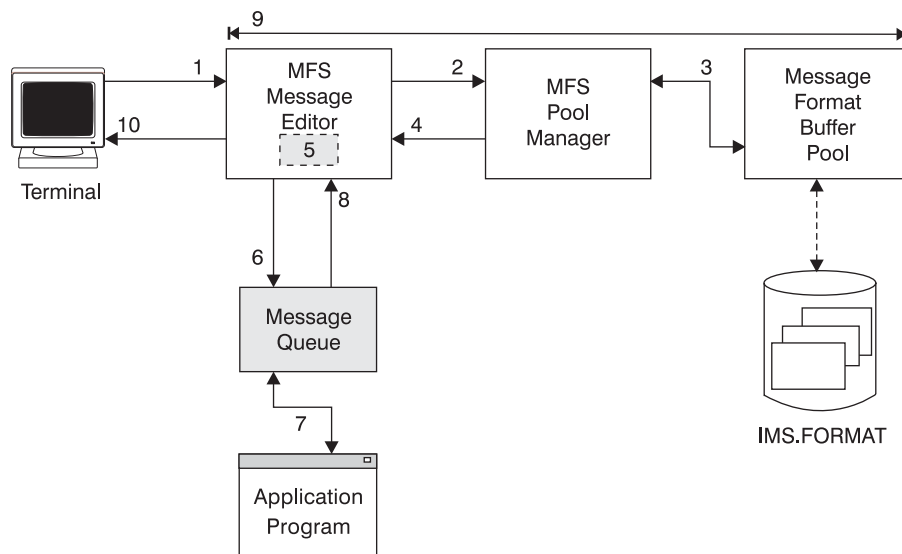

Figure 10. Overview of the MFS Online Environment

1. Input message is sent to the MFS message editor from the terminal.
2. MFS message editor requests pointer to MFS blocks from the MFS pool manager.
3. MFS pool manager checks the message format buffer pool to see if the blocks exist in the pool. If the blocks do not exist, the MFS pool manager reads the blocks from IMS.FORMAT into the buffer pool.
4. MFS pool manager sends the address of the MFS blocks to the MFS message editor.
5. MFS message editor formats the input message for the application program.
6. MFS message editor sends the formatted input message to the message queue to be processed.
7. Application program processes the message and sends the output message to the message queue.
8. Output message is sent from the message queue to the MFS message editor.
9. MFS processes the output message for the terminal just as it processed the input message (steps 2 through 6).
10. The formatted output message is sent to the terminal.

Figure 11 on page 77 show the MFS test environment. The steps listed following the figure correspond the numbers in the figure.

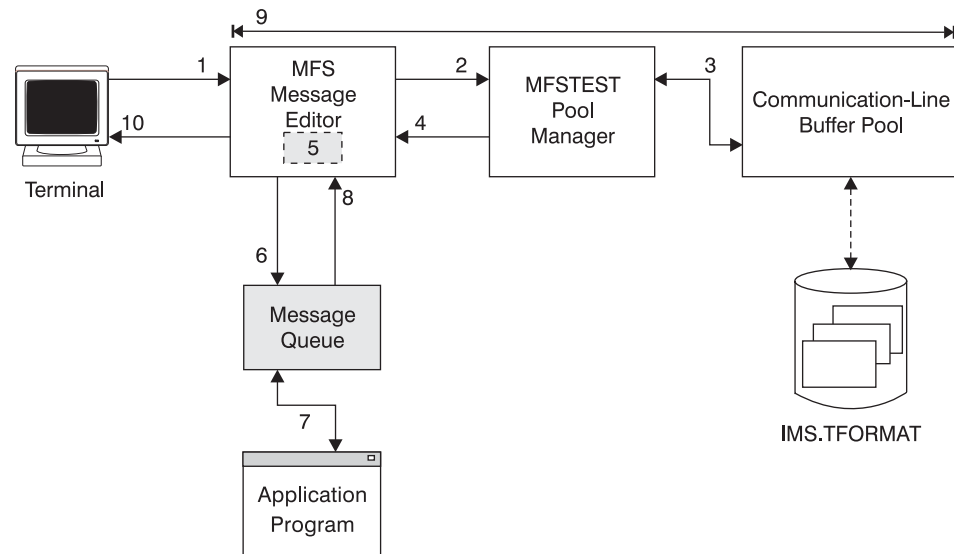

Figure 11. Overview of the MFS Test Environment

**Note:** You must use the /TEST MFS commands to begin MFS test mode.

1. Input message is sent to the MFS message editor from the terminal.
2. MFS message editor requests pointer to MFS blocks from the MFSTEST pool manager.
3. MFSTEST pool manager checks the communication-line buffer pool to see if the blocks exist in the pool. If the blocks do not exist, the MFS pool manager reads the blocks from IMS.TFORMAT into the buffer pool.
4. MFSTEST pool manager sends the address of the MFS blocks to the MFS message editor.
5. MFS message editor formats the input message for the application program.
6. MFS message editor sends the formatted input message to the message queue to be processed.
7. Application program processes the message and sends the output message to the message queue.
8. Output message is sent from the message queue to the MFS message editor.
9. MFS processes the output message for the terminal just as it processed the input message (steps 2 through 6).
10. The formatted output message is sent to the terminal.

The message editor and MFS pool manager operate online during the normal production mode of operation. The message editor performs the actual message formatting operations using the control block specifications.

Two other MFS components, an MFS Service utility and an MFSTEST pool manager, are available to support optional MFS operations.

The MFS Service utility provides a method for additional control of the format control block data sets. It executes offline and is able to create and maintain an index of control blocks for online use by the MFS pool manager.

The MFSTEST pool manager replaces the MFS pool manager in order to support the optional MFSTEST mode of operation. The /TEST command with the MFS keyword places a logical terminal into MFSTEST mode. For each terminal in

## Message Format Service

MFSTEST mode, combining temporary format blocks with the use of other blocks that are already in production mode allows new applications and modifications to existing applications to be tested without disrupting production activity.

**Related Reading:** For more information on MFS support, see *IMS Version 9: Application Programming: Transaction Manager*.

### Administering MFS

To take full advantage of the flexible message formatting options offered by MFS and to ensure efficient MFS operation, an MFS administrator should be appointed. The MFS administrator should be responsible for MFS implementation and administration and should coordinate MFS application design and programming for the installation.

The responsibilities of an MFS administrator include:

- Establishing procedures for the submission of MFS control block requests by application development personnel.
- Establishing procedures and controls for the application of changes to the IMS.TFORMAT library.
- Defining MFS control blocks most efficiently in keeping with the requirements of the specific application and the overall system.
- Minimizing device character transmission, sharing MFS control blocks, and ensuring the most efficient use of MFS without jeopardizing application requirements or operator considerations.
- Establishing and documenting operator guidelines and system standards for MFS. The many options that MFS offers can result in confusing practices, unless you establish and follow standard procedures. Be sure to standardize certain aspects of format design in order to minimize terminal operator training and error rates.
- Deciding if and how the optional index directory should be used and determining buffer pool requirements.
- Monitoring the use of the MFS control blocks and of the MFS buffer pool with the IMS /DISPLAY command and IMS Monitor report output, and modifying MFS parameters as required.
- Making end users aware of the operating characteristics of the different device types and terminal subsystems.
- Informing others about the differences between the various partition formats.
- Establishing and informing others about naming conventions and guidelines. In particular, the MFS administrator should be able to discuss naming conventions for the partition descriptor blocks and the sizes of the display screen, the viewports, and the display characters.
- Communicating information on conventions for and restrictions on MFS formats.
- Defining screen sizes and feature combinations that are not included in the IMS stage-1 system definition.
- Creating the MFS device characteristics table control statements for processing by the MFSDCT utility (DFSUTB00). The MFS device characteristics table entries and default format control blocks are used for ETO terminals.
- Defining input message field edit routines and segment edit routines. MFS and all MFS-supported devices are able to use message edit routines. You can use these edit routines for such common editing functions as numeric validation or conversion of blanks to zeros.

IMS provides a sample of both a field edit and a segment edit routine.

**Related Reading:** For information on the timing within the MFS editing processing when these routines are activated and the coding requirements, see *IMS Version 9: Application Programming: Transaction Manager*.

The MFS administrator should be technically competent in all aspects of IMS relative to MFS:

- Online transaction processing
- IMS API for message processing
- Operation with remote controllers
- MFS implementation, device characteristics, and capabilities
- Interpretation of MFS statistics and related IMS Monitor report output

The administrator should also be familiar with the hardware and remote programs for SLU-P, Finance remote programs, or ISC subsystems if such programs are going to operate with MFS by using distributed presentation management.

In addition, because one administrative responsibility is minimizing device character transmission, the administrator should be familiar with the terminal hardware characteristics.

An MFS administrator must communicate with IMS system administrators and application developers, as well as programmable workstation developers and end users. The administrator must be able to enforce installation standards and to modify application specifications for MFS control blocks when necessary to benefit overall system performance. The procedures of related programming groups should recognize this authority of the MFS administrator.

### Advantages to Using MFS

Two primary advantages to using MFS are that it:

- Simplifies the development and maintenance of terminal-oriented application systems
- Improves online performance

To simplify IMS application development and maintenance, MFS performs many common application program functions and gives application programs a high degree of independence from specific devices or remote programs.

With the device independence offered by MFS, one application program can process data to and from multiple device types while still taking advantage of their different capabilities. Thus, MFS can eliminate or minimize the changes in application programs when new terminal types are added.

MFS makes it possible for an application program to communicate with different types of terminals without having to change the way it reads and builds messages. When the application program receives a message from a terminal, how the message appears in the program's I/O area is independent of the kind of terminal that sent it; the appearance depends on the MFS options specified for that program. If the next message that the application program receives is from a different type of terminal, the user does not need to do anything to the application program. MFS shields the application program from the physical device that is sending the message in the same way that a database program control block (PCB) shields a program from the data in the database and how it is stored.

## Message Format Service

Other common functions MFS performs include left or right justification of data, padding, exit routines for validity checking, time and date stamping, page and message numbering, and data sequencing and segmenting. When MFS performs these functions, the application program handles only the actual processing of the message data.

**Related Reading:** For information on user-written exit routines and how to use them, see *IMS Version 9: Customization Guide*.

Figure 12 shows how MFS can make an application program device-independent by formatting input data from the device or remote program for presentation to IMS, and by formatting the application program data for presentation to the output device or remote program.

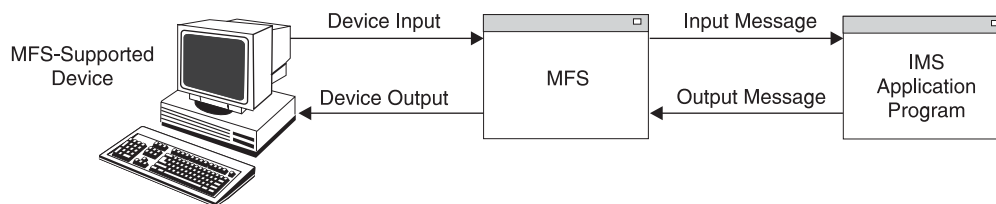

Figure 12. Message Formatting Using MFS

MFS also improves online performance of a terminal-oriented IMS by using control blocks that are designed for online processing. The MFS control blocks are compiled offline, when IMS is not being executed, from source language definitions. MFS can check their validity and make many decisions offline to reduce online processing. In addition, during online processing, MFS uses look-aside buffering of the MFS control blocks in order to reduce CPU usage and the channel costs of input/output activity.

Because MFS control blocks are reentrant and can be used for multiple applications, online storage requirements are reduced. Optional main-storage indexing and anticipatory fetching of the control blocks can also reduce response time. IMS gains additional performance improvements, because multiple I/O operations can execute concurrently in loading the format blocks from the MFS format library.

In addition, MFS uses z/OS paging services to reduce page faults by the IMS control region task.

Finally, MFS can reduce use of communication lines. Compressing and transmitting only the required data reduces line load and improves both response time and device performance.

## MFS Control Blocks

Users can specify four types of MFS control blocks to format input and output for the application program and the terminal or remote program.

### **Definitions:**

- *Message Output Descriptors (MODs)* define the layout of messages that MFS receives from the application program.
- *Device Output Formats (DOFs)* describe how MFS formats messages for each of the devices with which the program communicates.

- *Device Input Formats (DIFs)* describe the formats of messages MFS receives from each of the devices with which the program communicates.
- *Message Input Descriptors (MIDs)* describe how MFS formats messages so that the application program can process them.
- *Message descriptors* are both MIDs and MODs.
- *Device formats* are both DIFs and DOFs.

Because each MOD, DOF, DIF, and MID deals with a specific message, both a MOD and DOF must exist for each unique message a program sends, and both a DIF and MID must exist for each unique message a program receives.

## Overview of MFS Components and Operation

MFS has the following components:

- The MFS language utility, which generates control blocks from user-written control statements and places them in a library called IMS.FORMAT
- The MFS service utility, which is used for maintenance of the control blocks in IMS.FORMAT
- The MFS message editor, which formats messages according to the control block specifications generated by the language utility
- The MFS pool manager, which keeps the MFS control blocks that are required by the message editor in the main-storage MFS buffer pool
- The MFSTEST Pool Manager, which replaces the MFS pool manager when the language utility is being used in test mode

IMS online change also plays an important part in updating the MFS libraries, even though it is not part of MFS. Briefly, online change allows the control block libraries to be modified while the IMS control region is executing.

**Related Reading:** For a complete description of online change, see *IMS Version 9: Administration Guide: System*.

---

## Creating MFS Formats with SDF II

**Definition:** *SDF II* is an interactive tool for designing and generating MFS formats.

SDF II does not replace MFS, but it does make developing and maintaining MFS formats easier. Because SDF II uses a panel editor for designing and testing formats, it frees the MFS programmer from some of the tasks associated with coding MFS source statements.

With SDF II, application programmers and analysts who might not know the special requirements of MFS can perform a part of the programming job that would otherwise call for specialized knowledge. SDF II uses a panel editor, such as the one shown in Figure 13 on page 82, to define and test a panel.

## Creating MFS Formats with SDF II

```
DEFINE FORMAT
Format . . . . .Positions 1-75 or 80, Lines 1-24 of 24
Marks: V - C . L , S + Contents: FORMAT
001
002 *****
003 ** E M P L O Y E E P A Y R O L L **
004 *****
005
006 LAST NAME: FIRST NAME:
007
008 EMPL NO:
009
010 SOC SEC NO:
011
012 RATE OF PAY:
013
014
015
016 INPUT:
017
018
019
020
021
022
023
024
PF1=HELP 2=SPLIT 3=END 4=RETURN 5=RFIND 6=CHANGE
PF7=UP 8=DOWN 9=SWAP 10=LEFT 11=RIGHT 12=CURSOR
```

Figure 13. Example of SDF II Panel Editor

After testing the panel, the SDF II user can automatically generate the MFS source code, shown in Figure 14 on page 83, that is needed for the format definition. Using MFS only, the programmer would need to code these statements manually.



```

DOF
PAYF      FMT
          DEV      TYPE=(3270,2),FEAT=IGNORE,DSCA=X'00A0'
          DIV      TYPE=INOUT
          DPAGE    CURSOR=((5,15))
          DFLD    '*****',POS=(1,21)
          DFLD    '* EMPLOYEE PAYROLL *',POS=(2,21)
          DFLD    '*****',POS=(3,21)
          DFLD    'LAST NAME:',POS=(5,2)
LNAME     DFLD    POS=(5,15),LTH=16
          DFLD    'FIRST NAME:',POS=(5,36)
FNAME     DFLD    POS=(5,48),LTH=16
          DFLD    'EMPL. NO:',POS=(7,2)
EMPNO     DFLD    POS=(7,11),LTH=6
          DFLD    'SOC SEC NO:',POS=(9,2)
SSN       DFLD    POS=(9,14),LTH=11
          DFLD    'RATE OF PAY: $',POS=(11,2)
RATE      DFLD    POS=(11,16),LTH=9
          DFLD    'INPUT:',POS=(16,2)
INPUT     DFLD    POS=(16,9),LTH=30
          FMTEND

MID
PAYIN     MSG      TYPE=INPUT,SOR=(PAYF,IGNORE)
          SEG
          MFLD    'PAYUP '      SUPPLIES TRancode
          MFLD    LNAME,LTH=16
          MFLD    FNAME,LTH=16
          MFLD    EMPNO,LTH=6
          MFLD    SSN,LTH=11
          MFLD    RATE,LTH=9
          MFLD    INPUT,LTH=30,JUST=R,FILL=C'0'
          MSGEND

MOD
PAYDAY    MSG      TYPE=OUTPUT,SOR=(PAYF,IGNORE)
          SEG
          MFLD    LNAME,LTH=16
          MFLD    FNAME,LTH=16
          MFLD    EMPNO,LTH=6
          MFLD    SSN,LTH=11
          MFLD    RATE,LTH=9
          MFLD    INPUT,LTH=30,JUST=R,FILL=C'0'
          MSGEND

```

Figure 14. MFS Source Statements

SDF II is designed for use on a 3270–display device; however, SDF II can create formats for all devices supported by MFS.

**Related Reading:** For more information on SDF II, see *Screen Definition Facility II General Information*.

---

## Basic Edit

If you do not use MFS, an IMS function called basic edit performs message editing.

For input messages, basic edit:

- Translates messages to uppercase, if specified by the EDIT=UC parameter on the system definition TRANSACT macro.
- Removes leading control characters from the first segment of each message. Leading blanks are also removed from the first segment if the message is not the continuation of a conversation or a message from a terminal in preset mode.
- Removes leading control characters from all subsequent message segments, if the message type is a transaction or a command (except the /BROADCAST command).

## Basic Edit

- Removes line control characters from all segments.
- Removes trailing carriage return and end-of-block characters from all segments of a transaction.
- Eliminates backspaces, on a one-for-one basis, from all segments when the entering or transmission of backspaces is a normal correction procedure on the entering terminal.
- Removes the password and replaces it with a blank when necessary to provide separation between the transaction code, logical terminal, or command verb, and data that follows.
- Inserts, in front of data that is entered in the first segment of a message, the transaction code or logical terminal name defined by the prior /SET command. A blank is inserted following the transaction code, if it is necessary to obtain separation between the inserted transaction code and the entered data.
- Adds a nonconversational transaction code to the first segment of the next input message, if a terminal is in conversation mode and the application terminates the conversation by inserting a nonconversational transaction code into the SPA.

**Related Reading:** For more information on conversational transactions, see *IMS Version 9: Application Programming: Transaction Manager*.

- Removes the function management header (FMH), if any, that appears at the beginning of the first transmission of a chain for VTAM-supported devices.
- Deblocks message segments at each interrecord separator (IRS) control character, and discards the IRS control character for input from a SLU-1 card reader, a transmit data set (TDS), or a user data set (UDS).
- Deblocks message segments at each new line or forms-feed control character if the optional MFS editing is not selected for SLU-1 consoles. This character can be discarded, depending on the criteria previously described.
- Treats the presence of a TRN (X'35') character immediately followed by a length in the next byte as transparent data.

For output messages, basic edit:

- Changes nongraphic characters in the output message before the data goes to the device.
- Inserts any necessary idle characters after new-line, line-feed, and tab characters.
- Adds line control characters for the operation of the communication line.

For basic edit support of SLU-1 transparent data, basic edit does not alter or delete characters following the destination and password fields if transparent processing has been requested. Indicate transparent processing by specifying:

- BINPDSB1=BINTRNDS on the bind image for VTAM-type SLU-1 terminals
- Edit option BASIC=TRN on the COMPT1 parameter of the IMS TERMINAL macro or ETO descriptors for SLU-1 terminals

---

## IMS Editing for Intersystem Communication (ISC)

IMS recognizes several options on a message-by-message basis when communicating with ISC. IMS recognizes the following options:

- Use basic edit.  
The destination process name (DPN) is BASICEDT, which is a reserved IMS name.
- Treat the data as transparent data.

The IMS preset destination mode, which is established by the /SET command, is used. This option is used if a /SET command is in effect for a given session and a primary resource name (PRN) is not specified on the ATTACH or SCHEDULER FMH. While this option is in effect, IMS cannot recognize input commands within this input data stream.

- Do not edit data that follows the transaction code and input password fields.  
The input destination and security checking is the same as in basic edit. A / as the first character indicates an IMS command and causes the IMS preset destination mode to be bypassed or terminated. No additional editing is done on the input message following the input transaction code or LTERM name and optional password field. This is the default input edit for ISC under each of the following conditions:
  - ATTACH or SCHEDULER FMH is not included in input
  - ATTACH or SCHEDULER FMH does not specify a DPN
  - ATTACH or SCHEDULER FMH specifies a DPN but not a PRN
- Do nothing.  
IMS uses the input PRN ATTACH parameter as the transaction code or LTERM name for the duration of the single input message. Subsequently, the original IMS preset value can be used again. Basic edit treats the input as transparent with password security already checked.

The chosen option depends on the destination process name (DPN) and the data received by IMS. The DPN is specified on the ATTACH or SCHEDULER FMH.

If a DPN of ISCEDT or its alias is specified the second through fourth options are chosen. The alias for ISCEDT is defined using the EDTNAME keyword on the COMM macro. ISCEDT is also a reserved IMS name.

**Related Reading:** For more information on using basic edit for ISC, see *IMS Version 9: Customization Guide*.

---

## Transparency Option

Transparent data includes programmed symbols, extended field attributes, and commands. These unprintable characters might appear on the 3270 screen as hyphens or another representation for unprintable characters.

**Related Reading:** For more information on the extended field attributes, see *IMS Version 9: Application Programming: Transaction Manager*.

If IMS attempts to send transparent data to an IBM 3270 terminal that is unable to receive the data, an error is returned to IMS, and the terminal is taken out of service. To restart the terminal, the master terminal operator must issue the /START command.

For LU 6.1, input is processed using the transparency option of basic edit if the primary resource name (PRN) in the function management header (FMH) contains a transaction. Otherwise, the data stream is only scanned for the transaction code and optional password. The remaining data is treated as transparent data.

### Unprotected Screen Option

When the screen is in unprotected status, IMS can send output to the terminal at any time without requiring input from the terminal. This option can be used on a terminal-by-terminal or message-by-message basis.

---

### Bypassing MFS Editing

This topic describes how to bypass MFS formatting for output messages.

The following topics provide additional information:

- “When To Bypass MFS Editing”
- “Locking and Unlocking the Terminal Keyboard”

#### When To Bypass MFS Editing

IMS enables an IMS application program to bypass MFS formatting of an output message destined to an IBM 3270 or to SLU-2 devices. This bypass is intended for subsystems or installation support programs that execute under IMS.

**Recommendation:** Do not use this bypass for IMS application programs, because the application program loses the productivity, device independence, and migration benefits associated with MFS.

When MFS is bypassed on output, the application program constructs the entire 3270 data stream, beginning with the command code and ending with the last data byte. The user might want to bypass the MFS edit function to allow application programs to receive the 3270 input data stream from the terminal without IMS editing.

#### Locking and Unlocking the Terminal Keyboard

When the application uses MFS bypass and the reserved format name DFS™.EDTN, IMS enables the application program to lock or unlock the terminal keyboard. If the lock option is specified, the program is responsible for unlocking the keyboard after processing is completed. If the unlock option is specified, IMS controls the locking and unlocking of the keyboard.

**Related Reading:** For information on how to bypass MFS editing, see “Application Programming Using MFS” in *IMS Version 9: Application Programming: Transaction Manager*.

---

### IMS Sensitivity to Nongraphic Message Data

This topic describes the sensitivity IMS has to specific characters when users attempt to send and receive nongraphic data in IMS messages.

The following topics provide additional information:

- “Output Message Segment Editing”
- “Editing of Input Message Segments by MFS” on page 87
- “Editing of Input Message Segments by Basic Edit” on page 87

#### Output Message Segment Editing

For output message segments that MFS edits, only graphic data (X'40' through X'FE') is contained in the output message that is presented to the device.

Nongraphic characters, if present in the output message, are changed by MFS before the data is presented to the device. Device control characters HT, CR, LF, NL, and BS are changed to X'00' for 3270 data streams. For all other device types, all nongraphic characters are also changed to blanks.

If the Distributed Presentation Management (DPM) option of MFS is used for IBM 3600 controllers, the user can specify GRAPHIC=NO in the SEG statement. Nongraphic characters, if present in the output segment with GRAPHIC=NO specified, are presented unchanged to the remote program.

For programmable workstations that are supported through VTAM, IMS can insert function management headers (FMHs) and can perform additional editing for device control sequences when splitting a single IMS segment into multiple transmissions.

### Editing of Input Message Segments by MFS

If MFS is defined for a device, you should be aware of the following:

- Specify GRAPHIC=NO in the SEG statement to prevent uppercase translation on a segment if the destination requests it with the EDIT=UC specification on the system definition TRANSACT macro.
- If the first input record is from a 274x, 3600, SCS1, or SCS2 device, or from DPM-An, the segment is discarded if the final characters of the segment are:
  - Two asterisks (\*\*)
  - Two asterisks followed by NL (\*\*X'15')
  - Two asterisks followed by IRS (\*\*X'1E')
- The presence of two slashes (//) at the beginning of a message segment is considered an escape sequence.
- If the card feature is defined for an SCS1 device (with the CARD=operand in the DEV statement), all control characters are removed from magnetic card input before the data is presented to the input MFLD.

The definition of the MFS delete characters (LDEL=operand in the DEV statement) and field tab character (FTAB= operand in the DEV statement) for MFS-supported devices, excluding IBM 3270, can direct the editing of input message segments.

If the input is processed by MFS, the editing performed is dependent on the descriptions provided through the Message Format Service language utility. As input segments from the device might have no relationship to input message segments after MFS editing, the input segment from the device is not available to user-written edit routines. Input message segments after MFS editing are available to user-written edit routines.

**Related Reading:** For a description of MFS editing, see “Input Message Formatting” in “Message Formatting Functions” in *IMS Version 9: Application Programming: Transaction Manager*.

### Editing of Input Message Segments by Basic Edit

The following editing is done if basic edit is used for nongraphic message data:

- For the first segment of an input message when a terminal is not in conversation mode, leading characters less than X'41' are removed. For other than the first segment or when a terminal is in conversation mode, leading characters less than X'40' are removed.

## IMS Sensitivity to Nongraphic Message Data

- If a terminal is not in conversation or preset mode, a left parenthesis within the first nine positions of the first segment indicates the presence of a password. The left and right parentheses and the password are removed, and the segment is compressed.
- For non-SNA devices, the X'26' character that appears as the final character in a segment is removed.
- Two asterisks (\*\*) or two asterisks followed by NL (X'15') that appear as the final characters of a segment cause the entire segment to be discarded.
- For unbuffered keyboard devices (for example, IBM 2740-1 and 2741), backspace (X'16') characters are treated as character-delete indicators. Each backspace character and the preceding input character are removed from the segment.
- If the destination of the input message is a transaction, an NL (X'15') character appearing at the end of a segment is removed.
- If a device is in preset mode, the transaction code is added to the first segment.
- For input from IBM 3270 devices, the attention identifier and cursor address are removed, and all start buffer address sequences are changed to blanks.
- If the first character of any segment is a slash (/), the entire input message is treated as a command.
- If an input message is received from an NDS device, or if it is using Intersystem Communication, the data stream is handled wholly as transparent data or transparent except for edit of the transaction code and password.

---

## Controlling Output Devices

You can control an output device by using control characters in the second byte of the ZZ field of the message prefix (Z2). Follow these rules:

- SLU-1:
  - The Z2 field, bit X'80', should be set if the segment contains structured field data.
  - The Z2 field, bit X'40', should be set if the segment is the first segment of a new LPAGE series.
- Switched devices:
  - Exception:** IBM 3270
  - You can use the Z2 field in the message format to request that the line be disconnected after the present message is sent. This field is ignored if the output is physically sent to a device without this capability. The disconnect request is indicated using X'80' as the Z2 field value, this request is recognized if present in any segment.
- IBM 3270 printer (3270P device type):
  - You can use the Z2 field, bit value X'80', to specify the presence of command code and WCC character in the data stream, which is to be used when MFS editing is bypassed.
- Printer components:
  - The program can embed, in the text portion of the message, carriage return characters or new line symbols. If the output is going to an IBM 2780 or local printer (SYSOUT), the first two characters of the message can be carrier control characters.

---

## Small Buffer Devices

Some terminal devices have hardware limitations of the maximum buffer size that they can process. Additional limits can be imposed by software, either in the device or in the network. Exceeding these limits can result in an error and failure to deliver a message that is too large for the device to process. Be aware of what these limits are, and of the alternatives available to your application program.

Different device types specify the limits in different ways. For input, the SEGSIZE or BUFSIZE specification in IMS is relevant, and, for output, the OUTBUF specification. For VTAM terminals, the BIND RU size is based on these values. IMS supports message chaining for both input and output, but some terminals do not support chaining. In this case, message length is limited by sizes.

**Related Reading:** For more information on the SEGSIZE and BUFSIZE, see the description of the LINE and TERMINAL macros in *IMS Version 9: Installation Volume 2: System Definition and Tailoring*.

Your application program has control over the length of the output message, either directly or through the MFS definition being used to format the message. If you need to send a message that is longer than the maximum length supported by the target device, you must break the message into multiple messages, each of which is shorter than the maximum length for the device. The DL/I PURG call must be issued by your application program to do this. IMS delivers messages in the order that your application program inserts them; this is a good solution for devices that are not sensitive to message boundaries.

**Related Reading:** For information on the DL/I PURG call, see *IMS Version 9: Application Programming: Transaction Manager*.

---

## Controlling Output

Most output of an IMS online system goes to the input terminal. You have several choices for creating printer output.

- Use local printing through hardware-specific device support.
- Code the application program so that it directs response to the printer component of the input terminal.
- Use the /ASSIGN command to assign the response LTERM to a printer component.
- Code the application program to send output (SYSOUT) to an LTERM representing an IMS system printer.
- Code the application program to send output to an LTERM representing an alternative device for offline printing.

The choice is dependent on the application design. The use of the /ASSIGN command and the control of spool data sets are choices that might involve master terminal operator intervention.

With ETO, the output is associated with the user. The user can move from terminal to terminal. The output follows the user. When the output is available, use an autologon facility to generate a session for output delivery to a specified terminal.

### Using a Printer Component

The printer component for a terminal is often not in continuous operation. It might need a remote operator to supervise the paper supplies or special forms. The /COMPT command is used to make the device *ready* or *not ready* if the remote operator is a VTAM component. The operator can use the /ASSIGN command in order to direct output to a particular component.

**Related Reading:** For details on the /ASSIGN command, see *IMS Version 9: Command Reference*.

### Spooled Output Control

You need to be aware of requirements for IMS spooled output. This is because the output might be needed immediately by the end user or additional output can be impeded if allocated space is exhausted.

Given a spool line group, you need to be aware of how many data sets are used for output. A recommended definition is at least two data sets, one data set printing while the other receives additional input. The line number and PTERM references are also required.

At any time, you can use the following command to call for the spooled output to be scheduled to a printer:

```
/STOP LINE n PTERM nn
```

The action of this command is to close the data set and direct additional output to the next spool data set. If this is the last in the set, output goes to the first. If only one output data set exists at the time the print utility is scheduled, all messages for the LTERM are queued. This could rapidly add to the contents of the message queues. Message queues can fill very quickly, specially when the spool is the secondary master console. The IMSWTnnn procedure to execute the print utility is scheduled automatically by the data-set-full condition. A write error for the data set also starts the procedure.

The printing procedure is tailored to the line group data sets by system definition. You can invoke this procedure at any time by using a /START REGION IMSWTnnn command. If the data sets are not closed, current line output is queued.

Restart can affect spooled output handling. If output data sets were not printed from a prior execution, the /NRESTART command prevents additional output messages. The action of a /START LINE automatically schedules the IMSWTnnn procedure and frees the data set for output from the current system execution.

### Using Printer Components of the IBM 3270 Information Display System

You can define printer components to be part of an IBM 3270 Information Display System. This allows for printed copy of the video output (or input) to be sent to the printer's component.

This support covers the following printer component devices: IBM 3284, 3286, 3287, 3288, or 3289.

Your system definition input indicates whether these are to be connected through a polled-BSC or an SDLC line. The printed copy can be automatically produced or be operator controlled. The input message definition or the control prefix of the



output message can cause this automatic printing. The component must be attached to the same 3270 control unit as the display workstation containing the information to be copied—an IBM 3271/3274 or a 3275/3276.

**Restriction:** A locally attached 3270 does not support the copy function.

## Specifying Candidate Printers

With BSC 3270, using VTAM, requests for copying the screen content to a printer are directed to the first available printer on the same control unit as the screen.

**Definition:** *First available printer* refers to the sequence of TERMINAL macros for the devices. A predetermined sequence controls the order in which the printer components are selected for message output. Figure 15 shows two display workstation printer groups.

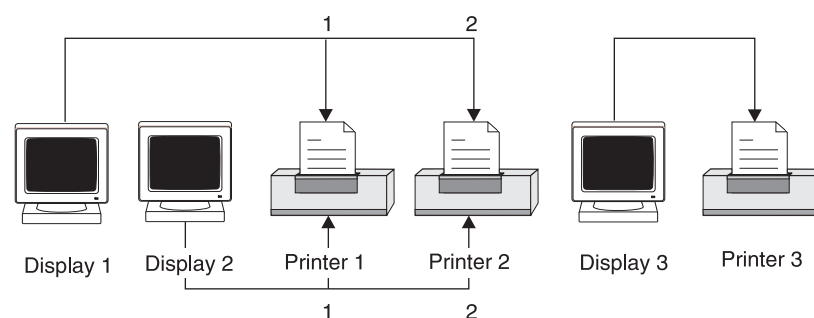

Figure 15. Sequence of IMS TERMINAL Macros

The first printer defined after a display is a candidate printer for that display. Any subsequently defined printer is also a candidate if no display is defined between it and the first candidate. In Figure 15, if a request is made for a printed copy of Display 1 or Display 2, IMS sends a 3270 copy command to Printer 3, if it is available. If Printer 3 is not available, IMS considers Printer 4. Printer 6 is not a candidate for Display 1 or Display 2, but it is a candidate for Display 5.

The copy function is not permitted to cross 3270 control-unit boundaries. For IBM 3274 and 3276 with SNA protocols, IMS sends the print request to the display, and the printer is selected by the controller. The printer need not be defined to IMS.

**Restriction:** The 3270R (non-SNA) copy function is not supported for ETO terminals.

## Operational Considerations

When a request for a copy operation is sent by the operator or an application program, the first available candidate printer is used for output. The search order corresponds to the system definition sequence. If a printer is stopped, already printing a message, in exclusive status, or not ready, the next candidate is chosen. If a copy request by an operator finds all printers busy, the keyboard is locked until a printer becomes available. Output messages that require the copy function are not sent if a candidate printer is unavailable. The display workstation receives an error message. A retry attempt is made for the message when the error message is cleared from the screen using the message advance function (PA2 key). The format description for a message can also specify a copy action. MFS uses the DSCA operand in the DEV statement to specify a copy action.

**Related Reading:** For more information on the DSCA operand of the DEV statement, see *IMS Version 9: Application Programming: Transaction Manager*.

### Sharing Printers between Systems

If you plan to share the use of a printer other than the master, IMS allows an online IMS system and another subsystem (possibly another IMS system) to alternate their use of the printer. The IMS support is for VTAM 3270 printers and, in the SNA environment, for LU-1 and LU-4 printers. The /OPNDST NODE Q command simulates a logon to IMS for the requested printer. The printer is automatically acquired when the owning subsystem frees the printer. You can queue output at any time independently of printer availability.

The system definition requirements are for the OPTIONS keyword of the TERMINAL macro. Specify:

<b>OPNDST</b>	so that the /OPNDST command is valid for this terminal
<b>SHARE</b>	so that the VTAM macro SIMLOGON can be issued by IMS in order to acquire the printer when data is queued for output
<b>RELRQ</b>	so that IMS releases the terminal to other VTAM subsystems upon their request

Specify RELRQ on the ETO logon descriptors to have the same features available for ETO terminals.

Each output message that is queued to a shared printer attempts a session.

As an alternative to immediate logon simulation and repeated failures while trying to acquire messages, you can use the Shared Printer exit routine (DFSSIML0). This exit routine monitors terminal (or transaction) status, and takes one of three actions:

- Ignores the request
- Simulates the /OPNDST command
- Queues a transaction for an automated operator program

The Shared Printer exit routine is not called if the printer is connected. You specify the SIMEXIT keyword on the COMM macro to call the Shared Printer exit routine. Your installation must write the Shared Printer exit routine and add it to the library of user routines prior to stage-2 of system definition.

**Recommendation:** Do not share the secondary master terminal.

#### **Related Reading:**

- For more information on the Shared Printer exit routine, see *IMS Version 9: Customization Guide*.
- For more information on different ways in which multiple users can share output terminals, see “Sharing Printers Using ETO” on page 181.

---

## Part 2. Transaction Manager in an IMSplex

### Chapter 5. Planning for Shared Queues . . . . . 95

Concepts for Operating in a Shared-Queues Environment . . . . . 96

    The Role of CQS in a Shared-Queues Environment . . . . . 96

    The IMS Role in a Shared-Queues Environment . . . . . 96

    How IMS Registers Interest in Queues . . . . . 97

    Message Flow in a Shared-Queues Environment . . . . . 98

    Units of Work (UOW) Tracking . . . . . 99

    Terminal Autologon . . . . . 99

    Message Switches . . . . . 99

    Dynamic Control Blocks . . . . . 99

    IMS Queue Manager . . . . . 99

    MTO Messages . . . . . 100

    Serial Transaction Processing . . . . . 100

    Conversational Transactions in a Shared-Queues Environment . . . . . 100

Planning for Operating in a Shared-Queues Environment . . . . . 101

    Configuring a Shared-Queues Environment . . . . . 101

    Enabling Shared Queues . . . . . 103

    Using the Common Queue Server . . . . . 108

    Accessing CQS with IMS Commands . . . . . 111

    Planning to Define List Structures . . . . . 112

    Using Associated Printers . . . . . 113

    Planning for IMS Front-End Switch . . . . . 113

    Determining Eligibility for Sysplex-Wide Processing . . . . . 114

    Managing APPC and OTMA Messages in a Sysplex Environment . . . . . 115

    Managing the IMS Dead-Letter Queue . . . . . 116

    Using the Expedited Message Handler . . . . . 116

    Requeuing Suspended Transactions . . . . . 117

    Scheduling AOI Transactions . . . . . 117

    Planning for MSC in a Shared-Queues Environment . . . . . 117

    Planning for RSR in a Shared-Queues Environment . . . . . 118

    Tuning for Performance in a Shared-Queues Environment . . . . . 118

### Chapter 6. Planning for Generic Resource Groups . . . . . 121

Requirements for Using Generic Resource Groups . . . . . 121

Generic Resource Group Restrictions . . . . . 122

| VTAM Generic Resource Affinity . . . . . 122

| Creating a Generic Resource Group . . . . . 123

| Specifying APPC Generic Resource Names . . . . . 123

| Initiating Sessions With IMS in a Generic Resource Group . . . . . 123

| XRF and Generic Resources . . . . . 124

| XRF with MNPS and Generic Resources . . . . . 124

| XRF with USERVAR and Generic Resources . . . . . 124

Changing the Logon Procedure . . . . . 124

Overriding the APPLID Field . . . . . 124

Determining When Affinities are Terminated . . . . . 125

Terminating Affinities That Persist . . . . . 125

Dropping an IMS System from a Generic Resource Group . . . . . 125

Resetting Terminal Status . . . . . 126

Logging on After IMS Failure with Affinity . . . . . 126

Controlling Generic Resource Member Selection . . . . . 126

Ensuring Consistency Across the IMSplex . . . . . 127

Bypassing Affinity Management During the IMS ESTAE Process . . . . . 128

### Chapter 7. Managing TM Resources in an IMSplex . . . . . 129

Resource Name Uniqueness . . . . . 129

Resource Type Consistency . . . . . 130

Global Callable Services . . . . . 130

Transaction Manager Resources . . . . . 131

    TM Resources: APPC Descriptors . . . . . 131

    TM Resources: VTAM LTERMs . . . . . 131

    TM Resources: MSNAMEs . . . . . 132

    TM Resources: VTAM Terminal Nodes . . . . . 132

    TM Resources: Transactions . . . . . 133

    TM Resources: User Names . . . . . 133

    TM Resources: User IDs . . . . . 134

IMS Activities and RM . . . . . 134

    Conversations . . . . . 134

    Initialization . . . . . 134

    Shutdown . . . . . 135

    Checkpoint . . . . . 135



---

## Chapter 5. Planning for Shared Queues

This chapter gives an overview of the concepts you should understand to use shared queues and then outlines the planning and administrative tasks associated with shared queues.

**Related Reading:** For information about using shared queues and the Common Queue Server, see the *IMS Version 9: Common Queue Server Guide and Reference*.

To manage message queues, your installation can use the IMS queue manager with either message queue data sets or shared queues.

**Restriction:** If you use shared full-function message queues on a Fast Path-eligible system, you must also define shared queues for EMH messages.

The first part of this chapter provides an overview of a variety of concepts that are integral to operating in a shared-queues environment:

- “The Role of CQS in a Shared-Queues Environment” on page 96
- “The IMS Role in a Shared-Queues Environment” on page 96
- “How IMS Registers Interest in Queues” on page 97
- “Message Flow in a Shared-Queues Environment” on page 98
- “Units of Work (UOW) Tracking” on page 99
- “Terminal Autologon” on page 99
- “Message Switches” on page 99
- “Dynamic Control Blocks” on page 99
- “IMS Queue Manager” on page 99
- “MTO Messages” on page 100
- “Serial Transaction Processing” on page 100
- “Conversational Transactions in a Shared-Queues Environment” on page 100

The second part of this chapter describes planning and administrative tasks for operating in a shared-queues environment:

- “Configuring a Shared-Queues Environment” on page 101
- “Enabling Shared Queues” on page 103
- “Using the Common Queue Server” on page 108
- “Accessing CQS with IMS Commands” on page 111
- “Planning to Define List Structures” on page 112
- “Using Associated Printers” on page 113
- “Planning for IMS Front-End Switch” on page 113
- “Determining Eligibility for Sysplex-Wide Processing” on page 114
- “Managing APPC and OTMA Messages in a Sysplex Environment” on page 115
- “Managing the IMS Dead-Letter Queue” on page 116
- “Using the Expedited Message Handler” on page 116
- “Requeuing Suspended Transactions” on page 117
- “Scheduling AOI Transactions” on page 117
- “Planning for MSC in a Shared-Queues Environment” on page 117

- “Planning for RSR in a Shared-Queues Environment” on page 118

---

## Concepts for Operating in a Shared-Queues Environment

Before operating in a shared-queues environment, read the information in these topics, which explains how operating in a shared-queues environment differs from operating in a non-shared-queues environment.

### The Role of CQS in a Shared-Queues Environment

The Common Queue Server (CQS) is a generalized server that manages objects on a coupling facility list structure, such as a queue structure or a resource structure. CQS receives, maintains, and distributes data objects from shared queues on behalf of multiple clients. Each client communicates with a CQS to access the shared queues. IMS is one example of a CQS client that uses CQS to manage both its shared queues and shared resources.

CQS uses the z/OS coupling facility as a repository for data objects. Storage in a coupling facility is divided into distinct objects called structures. Authorized programs use structures to implement data sharing and high-speed serialization. The coupling facility stores and arranges the data according to list structures. Queue structures contain collections of data objects that share the same name, known as queues.

**Related Reading:** For more information on CQS, see *IMS Version 9: Common Queue Server Guide and Reference*.

### The IMS Role in a Shared-Queues Environment

In a shared-queues environment, IMS acts as a front end for terminals, as a back end for processing, or as both simultaneously.

#### IMS as a Front End

As a front end, an IMS manages terminal resources and originates communications traffic, such as commands, transactions, and message switches. The message is typically the result of data that is entered at a terminal. A front-end IMS can also play the role of back end, if database, program, and transaction resources are defined.

#### IMS as a Back End

As a back end, an IMS manages transactions, database resources, and schedules application programs. A back-end IMS can also play the role of front end, if terminal resources are defined.

#### IMS as both a Front End and a Back End

As both a front end and a back end, IMS can process messages that are entered from one IMS terminal either on that IMS or on another IMS within the IMSplex.

Three processing environments exist when IMS acts as a back-end processor: local, remote MSC, and remote shared queues.

#### Definitions:

- *Local processing* occurs when the IMS dependent region that processes the message is on the same IMS as the IMS control region that received the message.
- *Remote MSC processing* occurs when the IMS dependent region that processes the message is on a different IMS than the IMS control region that received the message, and the message is sent to the remote IMS using MSC.

- *Remote shared-queues processing* occurs when the IMS dependent region that processes the message is on a different IMS than the IMS control region that received the message. In this case, however, the shared-queues facility contains the message that the remote IMS processes.

## How IMS Registers Interest in Queues

An IMS system registers and deregisters its interest in shared queues according to the type of work the IMS system can process. Consequently, the CQS for this IMS can notify the IMS when work is present on a queue. The types of work include:

- Transactions
- LTERMs
- MSC resources (such as remote LTERMs, remote transactions, and MSNAMEs)

In general, IMS registers its interest as the resources are added (or started), and IMS deregisters its interest as the resources are deleted (or stopped).

### Queue Types

Various types of queues are managed in a shared-queues environment. Each queue type is used for a different type of work. An IMS registers interest in only those queue types that it can process, based on the types of work you define for it.

The queue types and the work that IMS places on them are shown in Table 7.

*Table 7. Queue Types Maintained in a Shared-Queues Environment*

Queue Type	Description
Transaction-ready queue	Contains first qbuffer of messages that are destined for transactions
Transaction-staging queue	An internal queue that the IMS Queue Manager uses for holding those parts of messages that exceed a single qbuffer
Transaction-suspend queue	Contains first qbuffer of messages destined for suspended transactions
Transaction-serial queue	Contains first qbuffer of messages that are destined for serial transactions (transactions defined to IMS on the TRANSACT macro as SERIAL=YES)
LTERM-ready queue	Contains first qbuffer of messages that are destined for LTERMs or MSNAMEs
LTERM-staging queue	An internal queue that the IMS Queue Manager uses for holding those parts of messages that exceed a single qbuffer
APPC-ready queue	Contains first qbuffer of messages that are destined for APPC devices
REMOTE-ready queue	Contains first qbuffer of messages that are destined for remote transactions or remote LTERMs
OTMA-ready queue	Contains first qbuffer of messages that are destined for OTMA devices

### Registering and Deregistering Interest in Transactions

IMS registers or deregisters interest in transaction queues when certain actions are taken:

- IMS registers interest in transaction queues when any of the following events occurs:
  - IMS is initialized.

## Shared-Queues Concepts

- Transactions are added by online change after the /MODIFY COMMIT command is entered or, with global online change enabled, after the INITIATE OLC PHASE(COMMIT) command is entered.
- An operator enters the /START TRAN command.
- IMS deregisters interest in transaction queues when any of the following events occurs:
  - IMS shuts down.
  - Transactions are deleted by online change after the /MODIFY COMMIT command or, with global online change enabled, after the INITIATE OLC PHASE(COMMIT) command.
  - A /STOP TRAN command is entered.
- For IMS Fast Path:
  - IMS registers interest in a program queue during IFP region initialization for the name of the program that the region processes.
  - IMS deregisters interest in a program queue when the IFP region is terminated.

### Registering and Deregistering Interest in LTERMS

IMS registers and deregisters interest in LTERM queues when certain actions are taken:

- IMS registers interest in LTERM queues when any of the following events occurs:
  - A user logs on to a static terminal.
  - A user signs on to a dynamic terminal.
  - An LTERM is assigned to an active user or node.
- IMS deregisters interest in LTERM queues when any of the following events occurs:
  - A user logs off from a static terminal.
  - A user signs off from a dynamic terminal.
  - An LTERM is assigned to an inactive user or node.

### Registering Interest in MSC Resources

When an MSC logical link is started, IMS registers interest in the MSNAME that is defined with it. All remote transactions that are defined using the same SYSID pair are also registered.

When the logical link is stopped, IMS deregisters interest in the MSNAME and its associated remote transactions.

## Message Flow in a Shared-Queues Environment

In a shared-queues environment, when an IMS retrieves a message from a shared queue, the message is locked on that shared queue until the IMS unlocks or deletes the message. If IMS does not unlock or delete a message from the shared queue (for example, because of an IMS abend), the message remains locked. Locked messages are not available to other IMSs for processing. If you cold start the IMS after it locks messages on a shared queue, those messages remain locked, and they are moved to the cold queue.

If RM is defined with a resource structure, IMS releases any locked messages destined for an LTERM on the failing IMS. Messages become available to a user signing on to another IMS in the IMSplex.



**Definition:** The *cold queue* is a type of queue on which CQS places locked messages that it finds on its private queues after a client cold starts. Messages remain on the cold queue until they are unlocked or deleted.

### Units of Work (UOW) Tracking

In a non-shared-queues environment, a unit of work is tracked by a recovery token and by a unit of work (UOW). In a shared-queues environment, a unit of work is tracked using only a UOW. The UOW consists of the following fields:

- Originating-system message ID: Message ID assigned by the IMS that originates the message.
  - Originating IMSID
  - Time-stamp token
- Processing-system message ID: Message ID assigned by the IMS processing the message.
  - Processing IMSID
  - Time-stamp token

Because the UOW has IDs for both the system that originates the message and the system (if any) that processes the message, all messages that are associated with an original message can be tied together by the UOW (specifically, the originating-system message ID in the UOW).

### Terminal Autologon

Application programs can run on any IMS back-end system; therefore, output can be generated for the same user or terminal on any of these systems. In order to deliver output to all waiting users, an autologon terminal is often switched between IMSs in the IMSplex.

### Message Switches

In a shared-queues environment, messages are queued globally.

If the destination of a message switch is not defined on the local IMS, the Output Creation exit routine (DFSINSX0) is called to identify the destination. While ETO is active, if the exit routine indicates that the destination is an LTERM, the exit routine creates a dynamic user structure for the LTERM and then enqueues the message.

### Dynamic Control Blocks

To enable a user to enter transactions on IMS systems that do not have the transaction defined, a user can supply information in the Output Creation exit routine (DFSINSX0) to cause IMS to build a dynamic scheduler message block (SMB).

Input and output messages are enqueued to the shared queues, rather than to the control blocks.

### IMS Queue Manager

The IMS Queue Manager manages the IMS message queues. The Queue Manager data sets, SHMSG and LMSG, are not used to back up messages in a shared-queues environment. However, in order to reduce necessary changes during IMS system definition, the MSGQUEUE macro is still required; the data sets are defined, but they are never allocated or opened.

## Shared-Queues Concepts

The Queue Manager uses a number of real storage queue buffers to store the messages prior to placing them in the shared queues on the coupling facility. However, if the message needs to remain in the local IMS rather than being placed on the shared queues, the message is placed on a local queue. The local queues are also managed by the Queue Manager.

Messages that are placed on the shared queues are recoverable. Because the message queue data sets are not used, a message on a local queue is only recoverable if the log record for the message was written to the IMS log after the oldest of the last two checkpoints was taken.

In an XRF environment, the local queue manager data sets (QBLKSL, SHMSGSL, and LGMSGSL) are used. While the XRF alternate subsystem is tracking, local messages are placed in the local message queue data sets (messages for the active subsystem are on the shared queues). When the XRF alternate subsystem takes over the active subsystem, any messages in the local message queue data sets are merged with those on the shared queues.

### MTO Messages

Messages for the primary master terminal operator (MTO) are kept local and are not recovered across an IMS restart. Messages for the secondary MTO are placed on the shared queues using the LOCAL=YES option. These secondary MTO messages are recovered across an IMS restart and not are retrieved by the CQSREAD.

### Serial Transaction Processing

Messages for serial transactions are only processed by the IMS that places the messages on the queue. IMS keeps a transaction-serial queue for serial transaction messages in the coupling facility MSGQ structure.

**Related Reading:** For more information on the transaction-serial queue, see “Queue Types” on page 97.

AOI programs must define their transactions as serial (specified as SERIAL=YES on the TRANSACT macro).

### Conversational Transactions in a Shared-Queues Environment

In a shared-queues environment, conversation status is local to the IMS that initiates the conversation. When an IMS initiates a conversation, the following events occur:

1. IMS places the conversational transaction on the shared queues.
2. A locally defined SMB (or RSMB) or the Output Creation User exit routine (DFSINSX0) identifies the transaction as conversational.
3. Any IMS that registers interest in the transaction can process it. Also, any IMS can process any step of the conversation.
4. One IMS reads the message and schedules an application program to process the message.
5. The application program processes the message, saves data in the SPA, and responds to the initiating terminal.

The /EXIT, /HOLD, and /RELEASE commands apply only to the IMS that initiates the conversation.

---

## Planning for Operating in a Shared-Queues Environment

These topics describe the planning tasks that are associated with operating in a shared-queues environment.

### Configuring a Shared-Queues Environment

Figure 16 on page 102 and Figure 17 on page 103 illustrate two methods of configuring a shared-queues environment.

#### Cloned Configuration

A *cloned configuration* involves creating identical IMSs, with almost identical system definitions. Some differences in the definitions are required, such as MSC links. You can override the MTO definitions generated during system definition in PROCLIB member DFSDCxxx.

**Related Reading:** For more information on overriding the MTO definitions, see *IMS Version 9: Installation Volume 2: System Definition and Tailoring*.

The LTERMs, databases, and transactions for all the IMSs are defined identically. In this configuration, any IMS is able to process a particular transaction. Cloned configurations are useful for automatic workload balancing.

**Recommendation:** To take full advantage of a cloned configuration, ensure that the databases are shared across the IMSplex.

## Planning for Shared Queues

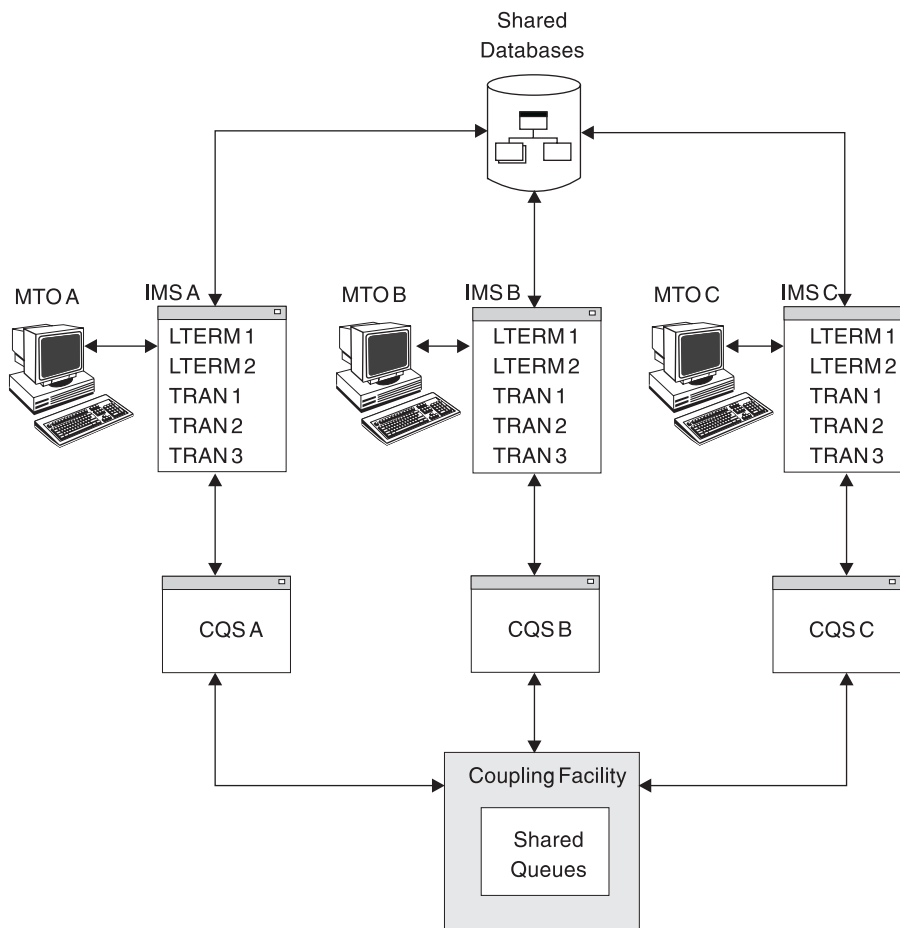

Figure 16. Cloned Configuration in a Shared-Queues Environment

### Partitioned Configuration

A *partitioned configuration* separates the VTAM network responsibilities from the database work. Each resource is defined to only one IMS.

**Example:** You can define an ES/9000<sup>®</sup> 9021 to manage the VTAM network as an IMS front end, while multiple smaller 9672 CMOS processors manage the database work.

Partitioned configurations are useful as replacements for, or additions to, MSC networks.

In the partitioned configuration in Figure 17, IMS A acts as the front end, and has LTERM 1, LTERM 2, and MTO 1 defined. IMS B, IMS C, and IMS D act as back ends, each with separate transactions and databases defined. Transactions in this configuration can run only on the IMSs on which they are defined.

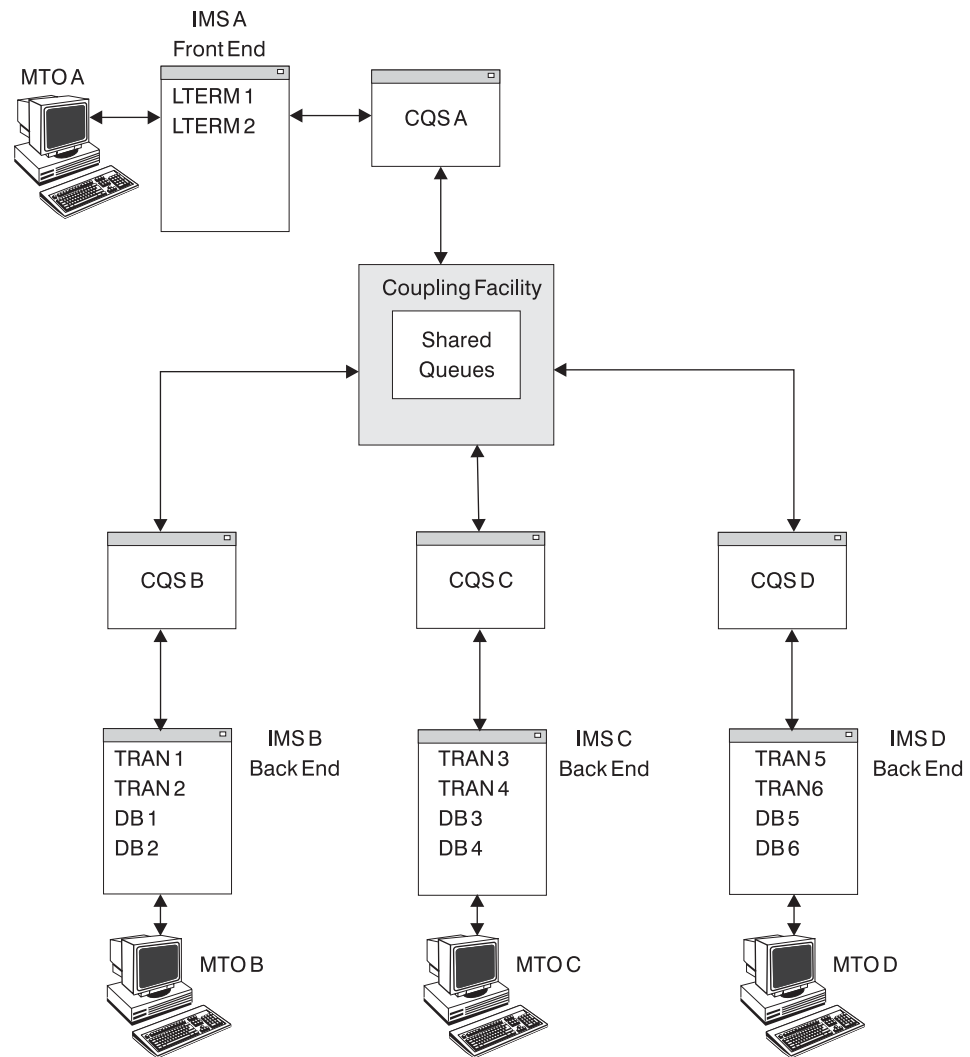

Figure 17. Partitioned Configuration in a Shared-Queues Environment

## Enabling Shared Queues

You enable shared queues by defining them in the z/OS coupling facility resource management (CFRM) policy. This topic discusses what you must include in the CFRM policy and the other definitions that must conform to the definitions you make in the CFRM policy.

### Defining the CFRM Policy

To enable shared queues, you must define a CFRM policy that contains structure names and attributes for all message queues. If you use Fast Path and share EMH queues, you must also include structure names and attributes for EMHQ structures. Figure 18 on page 105 contains a sample CFRM policy that defines both shared message queues and shared EMH queues.

Be sure that the structure names you define in the CFRM policy for message queues and any optional EMH queues are also defined in the following places:

- The shared-queues IMS.PROCLIB member (DFSSQxxx) parameters MSGQ= (and EMHQ= if you are sharing EMH queues)

## Planning for Shared Queues

- The CQS local structure definition PROCLIB member (CQSSLxxx) parameter STRNAME=
- The CQS global structure definition PROCLIB member (CQSSGxxx) parameters STRNAME= and OVFLWSTR=

**Recommendation:** If possible, place high-use structures on separate coupling facilities. For example, place your IMS data-sharing structures on a different coupling facility from your shared-queues structures. Place your VSAM and DB2 UDB for z/OS structures on yet another coupling facility. You can place low-use structures (such as those for RACF) on any coupling facility where space is available.

### **Related Reading:**

- For more information on defining a CFRM policy, see *IMS Version 9: Administration Guide: System*.
- For more information on definitions that are required to use CQS, see *IMS Version 9: Common Queue Server Guide and Reference*.
- For more information on IMS.PROCLIB, see *IMS Version 9: Installation Volume 2: System Definition and Tailoring*.

```
//POLICY EXEC PGM=IXCM2APU
//STEPLIB DD DSN=SYS1.MIGLIB,DISP=SHR
//SYSPRINT DD SYSOUT=A
//SYSIN DD *
DATA TYPE(CFRM)
DEFINE POLICY NAME(CONFIG01) REPLACE(YES)

CF NAME(LF01) TYPE(ND01%%)
           MFG(%%)
           PLANT(%%)
           SEQUENCE(%%%%%%%%%)
           PARTITION(0)
           CPCID(00)
           DUMPSPACE(1400)

STRUCTURE NAME(MVSL0GMSGQ01)
           INITSIZE(1024)
           SIZE(1536)
           PREFLIST(LF01)

STRUCTURE NAME(MVSL0GEMHQ01)
           INITSIZE(1024)
           SIZE(1536)
           PREFLIST(LF01)

STRUCTURE NAME(STRMSGQ01)
           INITSIZE(1024)
           SIZE(1536)
           PREFLIST(LF01)

STRUCTURE NAME(STREMHQ01)
           INITSIZE(1024)
           SIZE(1536)
           PREFLIST(LF01)

STRUCTURE NAME(STRMSGQ010FLW)
           SIZE(256)
           PREFLIST(LF01)

STRUCTURE NAME(STREMHQ010FLW)
           SIZE(256)
           PREFLIST(LF01)

/*
```

Figure 18. Sample CFRM Policy Containing Definitions of Shared-Queues

**Defining Message Queue List Structures:** You must define the primary list structure, MSGQ, to IMS before using shared queues. You can optionally define the overflow structure.

**Example:** In Figure 18, STRUCTURE NAME(IMSMSGQ01) defines a message queue structure, and STRUCTURE NAME(IMSMSGQ010FLW) defines an overflow structure for the IMSMSGQ01 message queue.

**Defining Fast Path Message Queue List Structures:** If you define the MSGQ primary list structure on an IMS that has Fast Path defined, you can optionally define a primary list structure for shared EMH queues. This structure is called the EMHQ structure. You can then optionally define an EMHQ overflow structure.

If you define an EMHQ structure, Fast Path transactions can be processed by IMSs in the shared-queues group. If you do not define an EMHQ structure, Fast Path transactions, if any, are only processed locally.

## Planning for Shared Queues

**Example:** In Figure 18 on page 105, STRUCTURE NAME(IMSEMHQ01) defines an EMHQ structure, and STRUCTURE NAME(IMSEMHQ010FLW) defines an overflow structure for the IMSEMHQ01 EMH queue.

### Defining a z/OS Log Stream

You must define a z/OS log stream. Create the following z/OS log stream definitions:

- In the GRSTNLxx PARMLIB member, specify every IMS in the sysplex environment as being in the same global resource serialization complex. This allows global serialization of resources in the IMSplex.
- Define log stream structure names and attributes in the CFRM policy for message queues and, if sharing, EMH queues.

**Example:** In Figure 18 on page 105, STRUCTURE NAME(MVSLOGMSGQ01) defines a log stream structure name for the message queues. Similarly, STRUCTURE NAME(MVSLOGEMHQ01) defines a log stream structure for Fast Path EMH queues.

- Install DFSMS and change SMS DATACLAS, STORCLAS, and MGMTCLAS constructs.
- Format the inventory coupled data set and define log streams and structure names.
- Update the COUPLExx PARMLIB member.
- Define the logger inventory data set in SYS1.PARMLIB(COUPLExx).
- Define log stream and coupling facility structure names to the logger inventory coupled data set.

**Related Reading:** For more information on defining the z/OS log stream, see *IMS Version 9: Common Queue Server Guide and Reference*.

### Defining CQS Parameters

To enable shared queues, define the following CQS parameters:

- CQS initialization parameters in PROCLIB member CQSIPxxx.
- CQS local structure definition parameters in PROCLIB member CQSSLxxx (for local structure definition). These definitions apply only to a single CQS.
- CQS global structure definition parameters in PROCLIB member CQSSGxxx (for global structure definition).

You must define one of each of these parameters for each structure pair. All of the CQs that share queues must have the same values specified in the CQSSGxxx PROCLIB member. If they differ, only the first CQS connects to the structure, and the others fail.

- Execution parameters (optional).

If you do not specify ARMRST=, CQSGROUP=, SSN=, STRDEFG=, or STRDEFL=, CQS retrieves the values that are specified in the CQSIPxxx PROCLIB member.

**Related Reading:** For more information about the CQS parameters, see the *IMS Version 9: Common Queue Server Guide and Reference*.

### Defining IMS Parameters

To enable shared queues, define the following IMS parameters:

- IMS control region execution parameters:

**LGMSGSZ=**

Specifies the record length of the long message.



**QBUF=**

Specifies the upper expansion limit of the queue buffer pool.

**QBUFHITH=**

Specifies a one- to three-digit number with a value in the range of 1 to 100 representing the high threshold percentage at which the message queue buffer is dynamically expanded. The default percentage is 80%.

**QBUFLWTH=**

Specifies a one- to three-digit number with a value in the range of 1 to 100 representing the low threshold percentage at which the message queue buffer is compressed. The default percentage is 50%.

**QBUFMAX=**

Specifies the maximum number of message queue buffers allowed in the queue buffer pool.

**QBUFPCTX=**

Specifies a one- to three-digit number with a value in the range of 1 to 100 representing the percentage of the originally allocated message queue buffers that are dynamically expanded when QBUFHITH is reached. The default percentage is 20%.

**QBUFSZ=**

Specifies the size of the queue buffers.

**SHAREDQ=**

Specifies the suffix of the shared-queues PROCLIB member, and is located in the PARMLIB member DFSSQxxx.

**SHMSGSZ=**

Specifies the record length of the short message.

- IMS startup parameters in PROCLIB member DFSSQxxx:

**CQS=**

Specifies the PROCLIB member containing the CQS procedure. CQS= is optional. The default is CQS=CQS.

**CQSSSN=**

Specifies the name of the CQS address space subsystem.

**EMHQ=**

Specifies the name of the EMH queues structure. If this statement exists, an EMHQ structure (and the other associated structures) is required in the shared-queues environment. If this statement does not exist, an EMHQ structure (and the other associated structures) is not required.

**MSGQ=**

Specifies the name of the message queues structure.

**SQGROUP=**

Specifies a one- to five-character identifier representing the XCF IMS shared-queues group name, which is concatenated to the letters DFS. All IMSs that share the same set of structures must specify the same SQGROUP= name. The SQGROUP= name can be the same as the CQSGROUP= name, which is specified in the CQSIPxxx PROCLIB member.

**WAITRBLD=Y|N**

Specifies whether activity on the EMHQ structure should wait until CQS completes the structure rebuild process. WAITRBLD=NO specifies that activity on the EMHQ structure should continue while CQS rebuilds the structure. WAITRBLD= is optional. The default is WAITRBLD=N.

## Planning for Shared Queues

**Related Reading:** For more information on these IMS parameters, see *IMS Version 9: Installation Volume 2: System Definition and Tailoring*.

### Using the Common Queue Server

IMS uses the CQS interface to manage the shared queues in a sysplex environment. From each IMS that acts as a CQS client, IMS uses this CQS interface to access the shared queues.

**Restriction:** When using the same LTERM name on multiple systems in a shared queues sysplex, all conversational and response mode reply messages must be processed by the originating terminal's system. This means that while a conversation or response mode operation is still in-progress on one IMS, the same LTERM name cannot be used, simultaneously or serially, by a terminal on another IMS. This Transaction Manager (TM) restriction applies to both Fast Path and non-Fast Path in a shared queues environment.

This topic briefly describes how to use CQS in an IMS environment. More information about CQS can be found in the *IMS Version 9: Common Queue Server Guide and Reference*.

#### Starting CQS

You can activate CQS in one of two ways:

- As a z/OS task, using the z/OS START command
- As a z/OS batch job

In addition, IMS automatically starts CQS, when appropriate.

To customize and monitor your CQS environment, you can supply any of the following exit routines:

- CQS Initialization/Termination
- CQS Client Connection
- CQS Queue Overflow
- CQS Structure Statistics
- CQS Structure Event

**Related Reading:** For information on CQS initialization parameters and CQS user-supplied exit routines, see *IMS Version 9: Common Queue Server Guide and Reference*.

#### Restarting CQS

Depending on whether a CQS structure contains data, you can warm start CQS or cold start CQS:

- If the structure is empty, you must cold start CQS.
- If the structure contains data, you can either warm start or cold start CQS.

When you have completed restarting CQS, the CQS ready message is issued (CQS0020I).

**CQS Warm Start:** During a warm start, CQS reads the checkpoint data set to find the log token representing the last system checkpoint. When CQS finds this log token, it initiates a warm start. If CQS fails to find this log token in the checkpoint data set, it reads the log token from the structure. If CQS finds the log token, it issues a WTOR in order to allow you to confirm the use of this token.

**CQS Cold Start:** When CQS cold starts after connecting to an empty structure, CQS purges all log records for the structure and performs a system checkpoint. After the system checkpoint is complete, the structure and CQS restart is complete.

### Using CQS User-Supplied Exit Routines

You can use the following exit routines to monitor and modify CQS activities:

- CQS Initialization/Termination exit routine
- CQS Client Connection exit routine
- CQS Queue Overflow exit routine
- CQS Structure Statistics exit routine
- CQS Structure Event exit routine

**Related Reading:** For more information on CQS exit routines, see the *IMS Version 9: Common Queue Server Guide and Reference*.

### Changing the Size of Coupling Facility Structures

The initial size of a structure on the coupling facility is determined by the value of the INITSIZE parameter in the CFRM policy. CQS allows you to dynamically reconfigure the size of a structure.

When the first CQS connects to a structure, the value specified for INITSIZE is the size of that structure. If enough free space does not exist for this INITSIZE value, the size of the structure becomes that of the available space in the coupling facility.

### Initiating System Checkpoint

As a system checkpoint for recovering CQS information during restart, each CQS writes its own control blocks to the z/OS log. To retrieve this restart information, CQS also writes information to the CQS checkpoint data set. CQS does not quiesce activity while the checkpoint is in progress.

**Checkpoint Data Sets:** For each structure pair, CQS maintains a checkpoint data set. CQS writes to a checkpoint data set and then uses it during restart. Checkpoint data sets are dynamically allocated during CQS initialization.

**How CQS Restarts after System Checkpoint:** During CQS restart, CQS reads the log records from the last system checkpoint and rebuilds the work that was in progress.

### Initiating Structure Checkpoint

In order to recover message queues, CQS takes structure checkpoints. CQS copies the shared queues from a structure pair to a structure recovery data set (SRDS). CQS quiesces activity while it performs part of this copy operation. CQS then performs a system checkpoint following each structure checkpoint.

### Recovering Structures

z/OS allows you to rebuild structures. You rebuild structures either by copying them or by recovering them.

**Rebuilding Structures:** One or more CQSs must be running in order to copy or recover structures and the messages on those structures. When the new structure is allocated, policy changes (such as structure location) are applied.

## Planning for Shared Queues

**Copying Structures:** If at least one CQS has access to the structure when structure rebuild is initiated, one of the CQS systems that still has access to the structure copies all of the messages (both recoverable and irrecoverable) from that structure to the new structure.

**Recovering Structures:** If no CQS has access to the structure when structure rebuild is initiated, the structure is recovered from the SRDS and the z/OS log. Irrecoverable messages (such as Fast Path input messages) are lost.

### Deleting Message Queues

You can delete message queues on a structure by deleting the structure. You can only delete a structure if no CQS is connected to it. To delete a structure and its queues:

1. Shutdown all CQs connected to the structure.
2. Enter the SETXCF FORCE,STRUCTURE,STRNAME=*strname* command.

Ensure that the *strname* in this command is the same as the *strname* specified in the CQS global structure definition PROCLIB member and the CQS local structure definition PROCLIB member.

### Monitoring and Recovering Structures Using the Queue Control Facility

You can copy and remove messages, and query shared queues for message counts and ages, using Queue Control Facility (QCF) two ways: by submitting a QCF BMP job to run on an IMS in the shared-queues group, or by using the QCF TCO/ISPF interface. Removing messages may be useful for clean-up or for re-inserting and processing messages later. You can also select and re-queue lost messages to the shared queues for reprocessing.

**Recovering the Cold Queue using QCF:** When an IMS is abended and then cold started, CQS places messages in progress at the abend on the cold queues of the CQS shared-queues structure. You can analyze or delete these messages on the cold queue structure using QCF. Additionally, with QCF, you can move the messages back to one of the processing queues for re-processing.

**Related Reading:** For more information on the QCF tool, see *IBM IMS Queue Control Facility for z/OS User's Guide*.

### CQS Logging and the z/OS Logger

The z/OS system logger records all information necessary for CQS to recover structures and restart. CQS provides a File Select and Formatting Print utility to read the log records.

#### **Related Reading:**

- For more information on defining the log stream, see *MVS Programming: Sysplex Services Guide*.
- For more information on the File Select and Formatting Print utility, see *IMS Version 9: Customization Guide*.

### Shutting Down CQS

You can issue the /CHE FREEZE command to shut down CQS. However, in this situation, if any in-flight work is existing, CQS does not shut down.

**Recommendation:** When in-flight work exists and no clients are connected to CQS, use the z/OS STOP command to shut down CQS.

**Related Reading:** For more information on the CQSSHUT request, see *IMS Version 9: Common Queue Server Guide and Reference*.

### Accessing CQS with IMS Commands

You can use the following IMS commands to interact with a CQS:

**/CQCHKPT SHAREDQ**

Initiates a CQS structure checkpoint.

**/CQCHKPT SYSTEM**

Initiates a CQS system checkpoint.

**/CQQUERY STATISTICS**

Displays statistics for primary and overflow structures.

**/CQSET SHUTDOWN SHAREDQ**

Sets status to take structure checkpoint at CQS shutdown.

**/DEQUEUE**

Dequeues one or more messages from one of the following:

- An outbound APPC queue
- A Fast Path program
- An LTERM
- An MSNAME
- An outbound OTMA queue
- A message queue
- A remote transaction or a remote LTERM
- A transaction

**/DEQUEUE SUSPEND**

Dequeues one or more suspended transactions.

**/DISPLAY CQS**

Displays CQS information that IMS tracks.

**/DISPLAY MODIFY**

Displays local work in progress.

**/DISPLAY OVERFLOWQ**

Displays a list of queue names that are in overflow mode.

**/DISPLAY QCNT**

Displays global queue information for a particular resource type.

**/DISPLAY STRUCTURE**

Displays structure status.

**/DISPLAY TRACE TABLE QMGR**

Displays queue manager trace table status.

**/DISPLAY TRACE TABLE SQTT**

Displays shared-queues trace table status.

**/TRACE SET OFF TABLE QMGR**

Stops trace of queue manager activity.

**/TRACE SET ON TABLE QMGR**

Starts trace of queue manager activity.

**/TRACE SET OFF TABLE SQTT**

Stops trace of shared-queues activity.

## Planning for Shared Queues

`/TRACE SET ON TABLE SQTT`

Starts trace of shared-queues activity.

These IMS commands apply to the local IMS only. Commands and command responses are not placed on the shared queues; therefore, they are not recoverable.

**Related Reading:** For the complete syntax of these IMS commands, see *IMS Version 9: Command Reference*.

## Planning to Define List Structures

CQS manages message queues that are shared within an IMSplex by using coupling facility list structures. A primary list structure holds the message queues. An overflow list structure, if you define one, holds additional queues after the primary list structure reaches a predefined threshold.

Define the following list structures:

- For IMSs that do not share Fast Path transactions, define only MSGQ primary structures and optional MSGQ overflow structures.
- For IMSs that do share Fast Path transactions, define both MSGQ primary (and optional overflow) structures and EMHQ primary (and optional overflow) structures.

Figure 19 and Figure 20 on page 113 show shared queues for IMS clients A and B.

In Figure 19, there is only the use of MSGQ structures, MSGQ structure recovery data sets (SRDSs), MSGQ checkpoint data sets, and a MSGQ z/OS log stream.

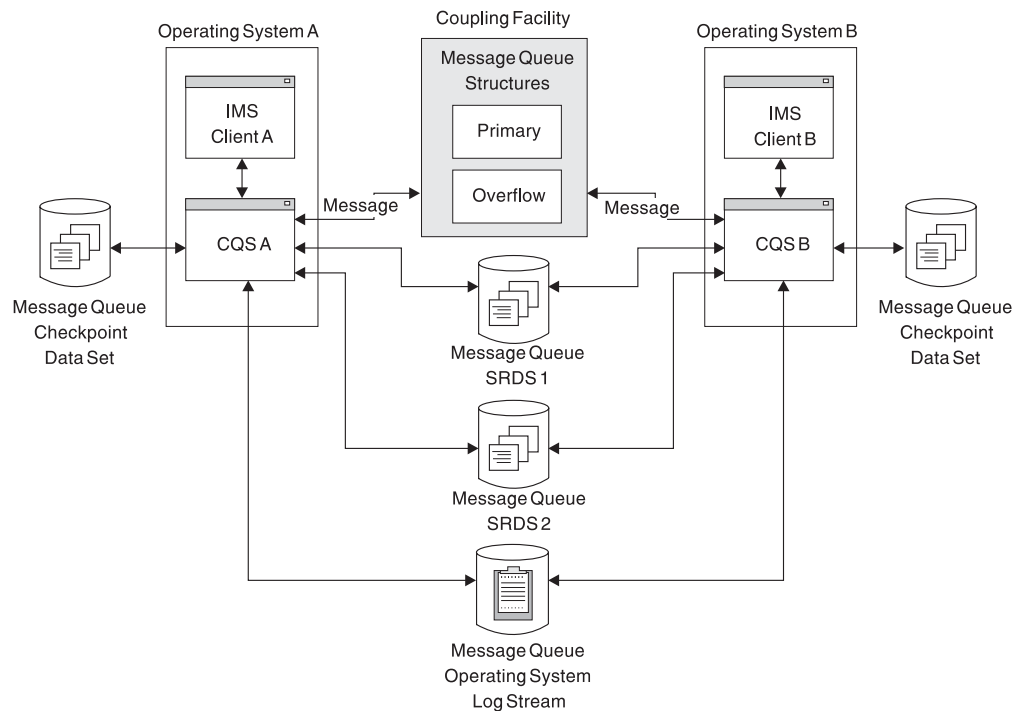

Figure 19. Shared-Queues Environment with its MSGQ List Structures

The configuration shown in Figure 20 on page 113 shows EMHQ structures, along with their corresponding structure recovery data sets (SRDSs), checkpoint data sets,

|  
|

and z/OS log stream. A configuration such as this one would also include MSGQs, but these are not shown in the figure.

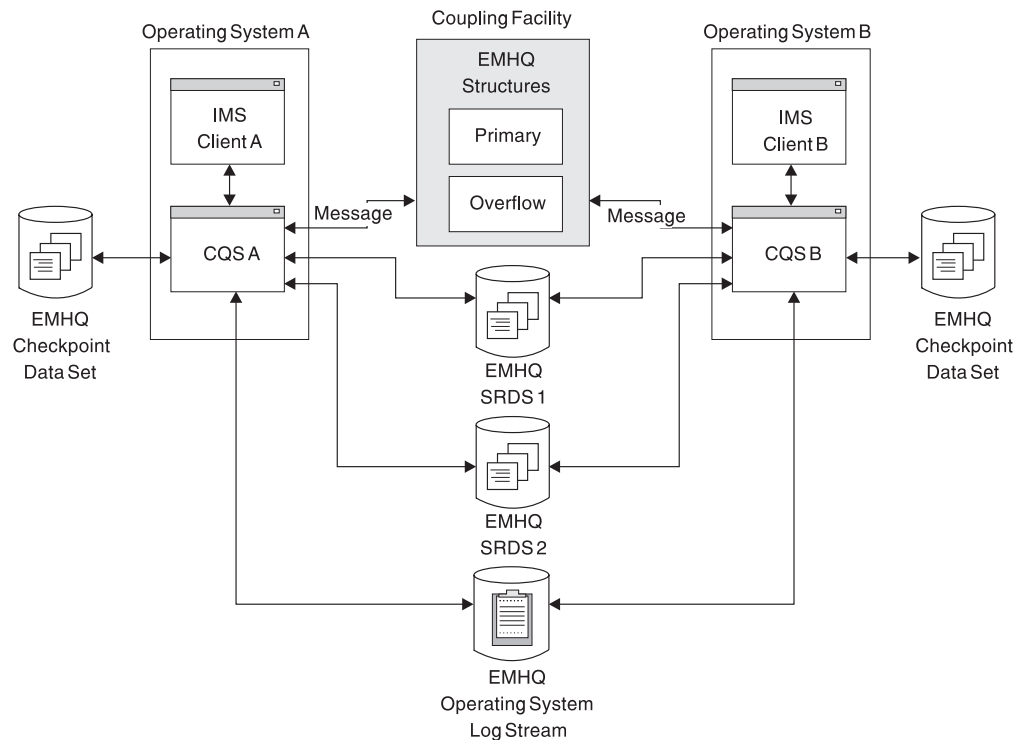

Figure 20. Shared-Queues Environment with its EMHQ List Structures

**Related Reading:** For information on how to define:

- MSGQ list structures, see “Defining Message Queue List Structures” on page 105.
- EMHQ list structures, see “Defining Fast Path Message Queue List Structures” on page 105.

## Using Associated Printers

In a shared-queues environment, when a user signs on and specifies associated printer information, the IMS front end registers interest for each associated LTERM. When the application inserts a message to one of these LTERMs, the IMS front end is notified and begins autologon for the printer.

**Recommendation:** Do not provide autologon parameters for these users in the IMS back end; doing so causes both the front end and back end to process autologon for the associated printers.

For shared printers in a shared-queues environment, shared printer terminals are often switched between IMSs in the IMSplex. This enables the output to be sent to any IMS in the IMSplex and to be printed.

## Planning for IMS Front-End Switch

Using IMS Front-end Switch (FES) in a shared-queues environment requires either:

- Coding the FES exit routine (DFSFEJ0) to route the input messages to the correct LTERM (to deliver FES reply messages correctly).

## Planning for Shared Queues

- Establishing ISC sessions between IMSs within the IMSplex (to ensure that FES input and reply messages are sent and received by any IMS).

### **Related Reading:**

- For information on the FES exit routine, see *IMS Version 9: Customization Guide*.
- For information on establishing ISC sessions, see “Controlling the Session (Session Control Protocols)” on page 301.

## Determining Eligibility for Sysplex-Wide Processing

**Definition:** An *IMS message* can be one of the following statements:

- A transaction or transaction response
- A message switch
- A system message
- A message from LU 6.2 or OTMA
- A command or command response

Some IMS messages in a shared-queues environment are eligible for sysplex-wide processing; others are not.

All messages (not including commands or command responses) are placed in shared queues.

### **Messages Eligible for Sysplex-Wide Processing**

Messages for the following types of communication are eligible to be processed on any IMS in the IMSplex:

- Transactions defined locally or using the Output Creation exit routine (DFSINSX0)
- Fast Path transactions defined using the DFSHAGU0 exit routine with sysplex processing option LOCAL FIRST or GLOBAL ONLY
- Fast Path messages for a program that is active in the IMSplex
- The following synchronous message types:
  - APPC
  - OTMA

See “Synchronous APPC and OTMA Messages” on page 115 for restrictions.

- LTERMs or by using the Output Creation exit routine (DFSINSX0)

**Definition:** A message for an LTERM can be:

- A transaction response
- A message switch
- A system message
- A command response

### **Messages Not Eligible for Sysplex-Wide Processing**

Messages for the following types of communication must be processed locally and are therefore not eligible for sysplex-wide processing:

- Serial transactions (transactions defined with SERIAL=YES specified on the TRANSACT macro)
- Commands and command responses



## Managing APPC and OTMA Messages in a Sysplex Environment

APPC and OTMA messages can be either asynchronous or synchronous. This topic discusses managing both types of APPC and OTMA messages.

### Asynchronous APPC and OTMA Messages

To ensure delivery of APPC and OTMA messages in a sysplex environment, enable APPC and OTMA on every back-end IMS in the shared-queues group. If a back-end IMS does not have APPC or OTMA enabled, any asynchronous APPC or OTMA output that is inserted to an alternate PCB is simply queued and not delivered until the operator issues a /STA APPC or /STA OTMA command.

Asynchronous APPC and OTMA messages created by a program-to-program switch can run on any IMS in the shared-queue environment.

### Synchronous APPC and OTMA Messages

Synchronous APPC and OTMA (send-then-commit) messages can run on any IMS in the shared-queues environment to distribute the transaction workload. Synchronous APPC or OTMA output inserted into the I/O PCB must be delivered by the front-end IMS. Therefore, APPC or OTMA will route the synchronous output back to the front-end IMS, regardless of which IMS is running the transaction. Non-conversational I/O PCB reply messages (less than 61K) are sent to the front-end IMS using XCF services. Conversational I/O PCB reply messages or any synchronous output messages greater than 61K are sent to the front-end IMS using shared queues and a special NOTIFY message that is sent using XCF. The IMSplex supports synchronous APPC and OTMA messages when the following conditions are true:

- All IMSs in the shared-queues group are Version 8 or higher.
- The DBRC command `change.recon minvers(81)` is issued.
- All operating systems are z/OS V1R2 or higher.
- RRS is active.
- The IMS control region parameter `RRS=Y` is defined for all of the IMSs in the IMSplex.
- `AOS=Y` or `AOS=F` is specified in the DFSDCxxx PROCLIB member.

If a synchronous APPC or OTMA transaction running in a back-end IMS results an asynchronous APPC or OTMA output that is inserted to an alternate PCB, APPC or OTMA must be enabled on the back-end IMS. Also, the asynchronous output will be delivered to the APPC or OTMA client directly from the back-end IMS.

Synchronous APPC and OTMA transactions initiated by a non-conversational program-to-program switch to local transactions always run on the same IMS system as the transaction that initiated them. For example, if synchronous TRAN A, which can run on any front-end or back-end IMS system in the sysplex, spawns synchronous TRAN B and asynchronous TRAN C, both TRAN B and TRAN C will run on the same IMS system as TRAN A.

### Related Reading:

- For more information on APPC and LU 6.2 processing, see Chapter 20, “Administering APPC/IMS and LU 6.2 Devices,” on page 405.
- For more information on APPC generic resources, see “Specifying APPC Generic Resource Names” on page 123.

## Planning for Shared Queues

- For more information on OTMA messages, see *IMS Version 9: Open Transaction Manager Access Guide and Reference*.

## Managing the IMS Dead-Letter Queue

IMS maintains a dead-letter queue only for local user structures. For shared queues on the coupling facility, use the /DIS QCNT MSGAGE command to display potential dead-letter queues. By examining the display output, you can determine whether a particular queue is a dead-letter queue and then take appropriate action.

**Related Reading:** For more information on the /DIS QCNT MSGAGE command, see *IMS Version 9: Command Reference*.

## Using the Expedited Message Handler

The IMS Fast Path Expedited Message Handler (EMH) can also use the shared queues in a shared-queues environment. IMS calls the Fast Path Input Edit/Routing exit routine to determine if an incoming message should be processed by Fast Path. If Fast Path must process the message, either the local IMS system processes it, or IMS places it on the shared queues.

Fast Path can use EMHQ structures, which are defined in the same way as the MSGQ structures (in the DFSSQxxx member of PROCLIB), to share Fast Path transactions. However, an IMS system with Fast Path installed is not required to have an EMHQ structure or share Fast Path transactions. If you do not define an EMHQ structure, all Fast Path transactions are processed locally.

If an IMS system joins the XCF group, abends, or shuts down, it notifies all sharing IMS systems by sending a message with the program name table. Sending this message makes all IMS systems aware of which IMS systems are servicing particular programs. Likewise, when a program is started or stopped on an IMS system, it notifies all sharing IMS systems, and each IMS system updates its program name table.

If no active region is available in the IMSplex to service a program, all IMS systems that have enqueued messages for that program issue message DFS2529I to the inputting terminals. These terminals are then unlocked. Any new input for the program is rejected with message DFS2533I.

Because Fast Path input messages are not recoverable, they are not written to the SRDS data set during CQS checkpoint. You can recover EMHQ structures; however, no Fast Path input messages are retained on the SRDS data set, and only Fast Path output messages can be recovered from the EMH queues. For each terminal awaiting output from an input message that has been lost during EMHQ structure rebuild, IMS sends message DFS2766I and unlocks the terminal. In addition, IMS writes a X'5936' log record for the lost message.

The EMHQ structures can be copied, and all messages are copied from the old structure to the new one, regardless of whether they are recoverable.

For EMHQ rebuild, it is possible to specify that the rebuilt EMHQ structure be accessible while the rebuild is in progress. Use the WAITRBLD= parameter in the DFSSQxxx PROCLIB member.

## Requeuing Suspended Transactions

When a transaction is suspended, it is placed on the transaction-suspend queue in the coupling facility. To make such messages available for processing, issue the /DEQUEUE SUSPEND TRAN command. Issuing this command moves the transaction to the transaction-ready queue or the transaction-serial queue.

The IMS that places the transaction on the transaction-suspend queue can be different from the IMS that issues the /DEQUEUE SUSPEND TRAN command. In this case, other IMSs that share the message (MSGQ) structure need to issue the /DEQUEUE SUSPEND TRAN command.

**Related Reading:** For more information on the transaction-suspend queue, the transaction-ready queue, or the transaction-serial queue, see “Queue Types” on page 97.

## Scheduling AOI Transactions

To ensure that the transaction runs locally, define all AOI transactions that are scheduled by the AOI exit routine as serial. Placing the AOI transaction on the shared queue allows any IMS to process it, regardless of whether the command applies to that IMS or not.

## Planning for MSC in a Shared-Queues Environment

IMSs in a multiple systems coupling (MSC) network can be part of a shared-queues environment, connected to IMSs outside the shared-queues environment. Each IMS within the IMSplex can act as any of the following:

- A front end, receiving messages from terminals or across MSC links
- A back end, processing messages received from a front end
- An intermediate subsystem, receiving messages and passing them on to other IMSs across MSC links

Although two IMSs can have MSC links defined, messages are placed on the shared queues from one of these IMSs and picked up for processing by another IMS within the IMSplex—these messages are not sent over the MSC links.

**Exception:** If one of these IMSs is running without shared queues enabled, the MSC links are used.<sup>5</sup>

To plan for using MSC in a shared-queues environment, take each of the following actions:

- Specify all remote IMSs on the MSNAME macro (SYSID and NAME), and assign a unique SYSID within the local IMS. These remote MSNAMEs remain stopped and are used only to route messages from any IMS within the IMSplex to a remote IMS.
- Define MSC remote system identifiers (SYSIDs), using the MSNAME macro, for each IMS within the IMSplex.
- Within the local IMS, make all SYSIDs be unique across all IMSs in the IMSplex and in the MSC network.
- Define remote transactions and LTERMs to the IMS that has the MSC link (the back-end IMS). Also define them to the front-end IMS. If you do not define

---

5. This situation might occur when migrating to a shared-queues environment.

## Planning for Shared Queues

them, IMS calls the User Output Creation exit routine (DFSINSX0) to determine whether the destination is local or remote, and to determine whether it is a transaction or an LTERM.

When an MSC link exists on the front-end IMS, you can use MSC for APPC and OTMA transactions in a shared-queues environment. The conversation is maintained with the local IMS but is not carried to the remote IMS. Therefore, the remote application program cannot issue the SET0 DL/I call, or the CPI-C verbs SEND\_ERROR and DEALLOCATE\_ABEND. Also, if the remote IMS allocates another APPC conversation, it receives the default user ID that is associated with the MPP region, and it does not use the original APPC user ID in order to verify security.

## Planning for RSR in a Shared-Queues Environment

Remote Site Recovery (RSR) allows you to quickly recover computer services in the event of an interruption. In a non-shared-queues environment, RSR recovers full-function databases, Fast Path DEDBs, IMS message queues, and the TM network.

RSR is supported in a shared-queues environment.

**Recommendation:** All IMSs that share a structure should:

- Be part of the same RSR service group
- Send log data to the same IMS tracking subsystem

If an RSR takeover occurs, and the active subsystems are restarted at the remote site, the new active subsystems must be started with the shared-queues option.

**Restrictions:** For RSR in a shared-queues environment:

- You cannot recover the shared message queues or the TM network after a remote takeover, because message queues are not logged in the IMS log. After takeover, cold start the DC system using the /ERESTART command.
- The tracking subsystem cannot track messages in real time, because it cannot run with the shared-queues option. To handle local message activity, the queue manager message queue data sets are used.

**Related Reading:** For more information on RSR in a shared-queues environment, see *IMS Version 9: Administration Guide: System*.

## Tuning for Performance in a Shared-Queues Environment

The structures and parameters you define for a shared-queues environment determine how the system performs.

### Tuning Structures and Parameters

To optimize system performance, try adjusting the following structures and parameters:

- The size of the IMS execution parameters:
  - LGMSGSZ=
  - QBUF=
  - QBUFHITH=
  - QBUFLWTH=
  - QBUFMAX=
  - QBUFPCTX=

- QBUFSZ=
- SHMSGSZ=
- The value of the CQS local structure definition parameter SYSCHKPT=
- The values of the CQS global structure definition parameters:
  - OVFLWMAX=
  - STRMIN=
- The size of the shared-queues structures on the coupling facility
- The size of the z/OS system log structure on the coupling facility
- The number of z/OS system log data sets that back up the z/OS system log structure
- The frequency of structure checkpoints

### Recommendation for Fast Path Transactions In a Shared Queues Environment

| For shared Fast Path transactions, if you specify LOCALONLY in the Fast Path Input  
| Edit/Routing exit routine (DBFHAGU0), do not change the size of your EMH  
| buffer pools. The same buffer pool space is required for a shared-queues  
| environment as for a non-shared-queues environment.

| However, if you specify LOCALFIRST in DBFHAGU0 for shared Fast Path  
| transactions and the transaction is processed locally, both a front-end EMH buffer  
| and a back-end EMH buffer are required in the local IMS system; consequently the  
| EMH buffer pool usage increases.

| In either case, analyze EMH buffer usage and adjust the space as needed.

**Related Reading:** For more information on tuning for performance in a shared-queues environment, see:

- *IMS Version 9: Administration Guide: System*
- *IMS Version 9: Common Queue Server Guide and Reference*

## Planning for Shared Queues

---

## Chapter 6. Planning for Generic Resource Groups

These topics describe the planning and administration tasks associated with using generic resource groups.

- “Requirements for Using Generic Resource Groups”
- “Generic Resource Group Restrictions” on page 122
- “VTAM Generic Resource Affinity” on page 122
- “Creating a Generic Resource Group” on page 123
- “Specifying APPC Generic Resource Names” on page 123
- “Initiating Sessions With IMS in a Generic Resource Group” on page 123
- “XRF and Generic Resources” on page 124
- “Changing the Logon Procedure” on page 124
- “Overriding the APPLID Field” on page 124
- “Determining When Affinities are Terminated” on page 125
- “Terminating Affinities That Persist” on page 125
- “Dropping an IMS System from a Generic Resource Group” on page 125
- “Resetting Terminal Status” on page 126
- “Logging on After IMS Failure with Affinity” on page 126
- “Controlling Generic Resource Member Selection” on page 126
- “Ensuring Consistency Across the IMSplex” on page 127
- “Bypassing Affinity Management During the IMS ESTAE Process” on page 128

---

### Requirements for Using Generic Resource Groups

Balancing sessions using generic resource groups requires the following:

- A sysplex environment.
- A z/OS coupling facility structure named ISTGENERIC defined in the active CFRM policy for the sysplex environment.
- A connection between the VTAM APPN node and the ISTGENERIC coupling facility structure.
- All IMS subsystems participating in the generic resource group reside in the sysplex environment.
- Each IMS subsystem participating in the generic resource group shares the same IMS generic resource name.
- An APPC generic resource name is defined to z/OS for LU 6.2 communications. Define this name on the GRNAME parameter of the LUADD statement in the APPC/MVS APPCPMxx member.
- All IMSs that belong to the generic resource group must be defined with equivalent specifications.

**Related Reading:** For information on VTAM and defining the ISTGENERIC coupling facility structure, see *z/OS V1R4: Communications Server: SNA Network Implementation*.

### Generic Resource Group Restrictions

When creating a generic resource group, system programmers should be aware of the following restrictions:

- A particular IMS cannot be a member of more than one generic resource group.
- The target of an MSC link cannot be a generic resource name.
- The generic resource name specified on the GRSNAME parameter must not match the name of an XRF USERVAR.

For more information on XRF and generic resources, see “XRF and Generic Resources” on page 124.

---

### VTAM Generic Resource Affinity

After VTAM selects a specific IMS subsystem in a generic resource group to perform the work of a specific terminal, VTAM generic resource (VGR) affinity is established, and all of the terminal’s subsequent sessions connect to the same IMS subsystem until IMS or VTAM resets the terminal’s affinity.

IMS assigns VGR affinity management to IMS or VTAM for each session depending on the status recovery mode of that session. IMS ignores the GRAFFIN= parameter, which is obsolete for VGR.

In general, when you have defined a Resource Manager and a resource structure, and the status recovery mode is LOCAL, a session has either both VGR and RM affinity, or neither.

**Related Reading:** For more information on RM affinity, the LOCAL status recovery mode, and using a resource structure to manage terminals, see “Resource Status Recovery” on page 39.

**Note:** For ISC terminals, VTAM and IMS do not release VGR affinities until all parallel sessions have been terminated.

#### VGR Affinity Management

Either IMS or VTAM can manage VGR affinities. An important difference between the two is the ability of each to reset affinities for terminals in the event of an IMS failure. If a terminal has an affinity with an IMS that fails, the terminal cannot continue work until its affinity is reset.

When VTAM manages affinities, if IMS fails, VTAM can reset the affinities of terminals that had sessions open with the failed IMS. With their affinities reset, the terminals can open a new session with another IMS in the generic resource group.

When IMS manages affinities, if IMS fails, IMS might not be able to reset the affinities between the terminals and the failed IMS. In this case, the terminals cannot open new sessions until the failed IMS is restarted.

The type of terminal and the status recovery mode you set for the terminal determine whether IMS or VTAM manages VGR affinities.

#### IMS-Managed Affinity

IMS manages VGR affinity for the following:

- Static terminals with recovery mode of LOCAL, where IMS sets VGR affinity because the terminal must not be allowed to access other IMSs. IMS ensures that VGR affinity matches RM affinity.



- Dynamic STSN terminals with status recovery mode of LOCAL, where IMS sets VGR affinity because the terminal must not be allowed to access other IMSs. IMS ensures that VGR affinity matches RM affinity because the user name and status recovery mode must be provided at logon.

---

### Creating a Generic Resource Group

You create a generic resource group by specifying the same generic resource name for all the IMSs participating in the generic resource group.

You can specify the generic resource name for each IMS in two ways:

- The GRSNAME= startup parameter in the IMS and DCC procedures.
- The VGRS parameter of the /START command when starting the control region of an IMS.

**Restriction:** The generic resource name specified on the GRSNAME parameter must not match the name of an XRF USERVAR.

#### Related Reading:

- For more information on the GRSNAME= startup parameter, see *IMS Version 9: Installation Volume 2: System Definition and Tailoring*.
- For more information on the /START VGRS command, see *IMS Version 9: Command Reference*.

---

### Specifying APPC Generic Resource Names

Specifying an APPC generic resource name enables LU 6.2 devices to participate in the session balancing provided by a generic resource group. Specify the APPC generic resource name on the GRNAME parameter of the LUADD statement in the APPC/MVS APPCPMxx member.

**Restriction:** The APPC generic resource name must be different from the name you specify on the GRSNAME execution parameter.

---

### Initiating Sessions With IMS in a Generic Resource Group

Sessions can be initiated either from IMS or from a terminal. All sessions initiated by IMS are generic sessions; that is, sessions in which affinity is established.

Sessions from a terminal can be initiated in the following ways:

- You can initiate a session with any IMS in a generic resource group by specifying the GRSNAME execution parameter. An affinity with the selected IMS is then established.
- You can initiate a session with a specific IMS by specifying the APPLID name of the system. In this case, no affinity is established.
- If an IMS in a generic resource group is also part of an XRF with MNPS system, you can initiate a session with that specific IMS using the MNPS name instead of the APPLID name. As when initiating a session with an APPLID name, no affinity is established.

#### Related Reading:

- For more information on XRF and generic resources, see “XRF and Generic Resources” on page 124.

- For more information on XRF systems and specifying the MNPS name, see *IMS Version 9: Administration Guide: System*.

---

## XRF and Generic Resources

Extended Recovery Facility (XRF) systems help ensure session persistence and the availability of IMS resources. There are two types of XRF systems: XRF systems that use VTAM multinode persistent sessions (MNPS) and XRF systems that use a USERVAR. XRF with MNPS systems can participate in a generic resource group, but XRF with USERVAR systems cannot.

### XRF with MNPS and Generic Resources

For XRF with MNPS systems in a generic resource group, VTAM associates the generic resource name with the MNPS name of the XRF with MNPS systems instead of the APPLID name. Terminals that want to log on directly to an IMS that is part of an XRF with MNPS system must use the MNPS name.

Including an XRF with MNPS system in a generic resource group does not guarantee session persistence for terminals logging on using the generic resource name unless every IMS in the generic resource group is also part of an XRF with MNPS system.

### XRF with USERVAR and Generic Resources

Although XRF systems with USERVAR cannot participate in a generic resource group, they can coexist in the same sysplex as a generic resource group. In this case, generic resource names and USERVARs must be different.

XRF with USERVAR systems can participate in a shared-queues environment.

For more information on XRF systems, see *IMS Version 9: Administration Guide: System*.

---

## Changing the Logon Procedure

You can provide the option of logging on using either a generic resource name or an IMS APPLID name; therefore, plan to make one or both of these names available in the logon procedure.

---

## Overriding the APPLID Field

Each IMS identifies itself to VTAM using the application name you specify in the APPLID= keyword of the IMS COMM system definition macro and in the VTAM APPL definition statement.

In order to keep the IMS definitions as similar as possible, you can specify the same name in the APPLID= keyword of the COMM macros for all the IMSs in a generic resource group. You must then override this name by specifying a unique APPLID name on the APPLID1 execution parameter.

Similarly, you can override the PASSWD field in the COMM macro by using the PASSWD= execution parameter.

**Related Reading:** For more information on the APPLID1 and PASSWD execution parameters, see *IMS Version 9: Installation Volume 2: System Definition and Tailoring*.

---

### Determining When Affinities are Terminated

When you terminate a session by logging off, IMS terminates the affinity between your node and the IMS generic resource member. However, in some situations, affinities persist. You can use several methods in order to terminate these affinities.

To display the list of IMSs and their affinities with specific nodes, use the `/DISPLAY AFFINITY` command.

**Related Reading:** For information on the `/DISPLAY AFFINITY` command, see *IMS Version 9: Command Reference*.

For information on how to terminate affinities that persist, see “Terminating Affinities That Persist.”

---

### Terminating Affinities That Persist

A terminal cannot participate in session balancing if it has a persisting affinity with a particular IMS from a previous session. When VTAM manages the VGR affinity, affinity is automatically reset at session termination. When IMS manages the VGR affinity, an affinity persists after a logoff or IMS failure in each of the following situations:

- The terminal is static with LOCAL status recovery mode, and has end-user significant status (Conversation, STSN, or Fast Path).
- The terminal is ETO SLUP or 3600 Finance terminal with LOCAL status recovery mode and RCVYSTSN=YES.
- The terminal is an ISC parallel-session terminal with LOCAL status recovery mode that has not quiesced.
- The terminal is an ISC parallel-session terminal, and one or more of the parallel sessions has not quiesced.

You can terminate an affinity using any of the following methods:

- Enter the `/CHECKPOINT` command with the LEAVEGR keyword.
- Use the Logoff or Signoff exit routine to reset terminal status.
- Cold start the IMS TM subsystem, and specify the GRSNAME when restarting IMS.

**Related Reading:**

- For information on the `/CHECKPOINT` command and the LEAVEGR keyword, see *IMS Version 9: Command Reference*.
- For information on the Logoff and Signoff exit routines, see *IMS Version 9: Customization Guide*.

---

### Dropping an IMS System from a Generic Resource Group

You can use the `/STOP VGRS` command to drop an IMS out of a generic resource group. Similarly, you can use the `/START VGRS` command to bring that IMS back into the generic resource group.

**Related Reading:** For more information on the `/STOP VGRS` and `/START VGRS` commands, see *IMS Version 9: Command Reference*.

### Resetting Terminal Status

You can reset terminal status (and thus terminate affinities) using one or more of the following:

- An authorized command
- The Logoff (DFSLGFX0) exit routine
- The Signoff (DFSSGFX0) exit routine
- The RCVYFP, RCVYSTSN, and RCVYCONV parameters
- The NONE status recovery mode

The Logoff (DFSLGFX0) exit routine resets a terminal's status during a logoff. Similarly, you can use the Signoff (DFSSGFX0) exit routine to reset a user's status during a signoff. Resetting terminal or user status enables IMS to terminate an affinity with the terminal, enabling the terminal to log on again and participate in session balancing.

**Related Reading:** For more information on the Logoff and Signoff exit routines, see *IMS Version 9: Customization Guide*. For more information on the NONE status recovery mode and the RCVYFP, RCVYSTSN, and RCVYCONV parameters, see "Status Recovery Mode for End-User Significant Status" on page 40.

---

### Logging on After IMS Failure with Affinity

Suppose you are operating in a shared-queues environment, and your terminal is logged onto an IMS in a generic resource group. If that IMS fails, the affinity between that IMS and your terminal might persist. Consequently, you can have output messages waiting for you on that terminal. To obtain your messages, you can log onto another IMS within the generic resource group, provided that all of the following conditions exist:

- You log on using the APPLID name of another IMS within the generic resource group.
- Your output messages are not locked on the failed IMS, and those messages are not responses to either an IMS conversation or a Fast Path response-mode transaction.
- If you have a resource structure and Resource Manager, the status recovery mode is not LOCAL and there is not end-user significant status on the failed IMS (no RM affinity).

---

### Controlling Generic Resource Member Selection

You can control VTAM's selection of a generic resource member for a terminal when the terminal logs on. To control the selection process, use either the VTAM Generic Resource Resolution exit routine (ISTEXCGR) or the z/OS Workload Manager. Choosing between these facilities depends on the needs of your application program and on your installation requirements.

The criteria that VTAM uses to select a generic resource member are:

1. Existing affinity <sup>6</sup>
2. VTAM Generic Resource Resolution exit routine (ISTEXCGR)
3. z/OS Workload Management
4. Current session counts

---

6. VTAM maintains an affinity table in a list structure called ISTGENERIC on the coupling facility.

### **Related Reading:**

- For more information on the VTAM Generic Resource Resolution exit routine (ISTEXCGR), see *z/OS: Communications Server: SNA Customization*.
- For more information on the z/OS Workload Management, see *MVS Planning: Workload Management* and *z/OS : MVS Programming: Workload Management Services*.

---

## Ensuring Consistency Across the IMSplex

Inconsistencies in definitions, operator commands and procedures, and exit routines can create problems within a generic resource group:

- At a minimum, they can confuse terminal users, who are unaware of being in session with different IMSs from one logon to another logon.
- At worst, they can cause processing disruptions.

**Recommendations:** To ensure consistency across a generic resource group:

- Use equivalent specifications when defining the member IMSs.  
**Example:** If one IMS specifies that ETO be included (ETOFEAT=YES on the IMSCTRL macro), all other IMSs in the generic resource group should specify that ETO be included.
- Specify execution parameters consistently across generic resource members.  
**Example:** IMSs in a generic resource group should each specify that ETO be enabled or not be enabled.
- If ETO is included, specify the same information on the ETO descriptors for each IMS generic resource group member.
- Use the same naming conventions for LTERMs and transactions across a generic resource group. If the same LTERM name is assigned to different nodes on different IMSs, unpredictable results might occur.

**Related Reading:** For more information about how to ensure name uniqueness and resource type consistency, see Chapter 7, “Managing TM Resources in an IMSplex,” on page 129.

- Make all terminal definitions consistent across generic resource members.  
**Example:** LTERM names should be consistently defined, during IMS system definition, to the same physical terminals on all the IMSs in the generic resource group.
- Ensure that master terminal operators (MTOs) on each IMS in the generic resource group have procedures for notifying the other MTOs about the commands they issue. If you are using a single point of control (SPOC), commands go to all IMSs that can process the commands and there is no need for the notification procedures.

**Example:** If you do not have Resource Manager (RM) and one MTO issues a /STOP command to stop a user on one IMS in a generic resource group, that user is stopped only on the IMS on which /STOP is entered. If you have RM and a resource structure, however, RM manages the user globally and the user is stopped on all the IMSs in the IMSplex.

**Related Reading:** For more information on using a SPOC and the Common Service Layer (CSL), which is needed to support a SPOC, see *IMS Version 9: Common Service Layer Guide and Reference*.

- Make exit routines functionally equivalent across a generic resource group—especially the Output Creation exit routine, the OTMA Routing exit routines, the Logon and Signon exit routines, and the Logoff and Signoff exit routines.

## Bypassing Affinity Management During the IMS ESTAE Process

If you use IMS to manage generic resource affinities, you can control whether or not IMS uses or bypasses the VTAM generic resource logic in the IMS ESTAE exit. To use the IMS ESTAE process, indicate GRESTAE=Y in the DFSDCxxx IMS.PROCLIB member. GRESTAE=Y indicates that IMS should follow the existing ESTAE logic to delete affinity for nodes where no status remains before closing the ACF/VTAM ACB. GRESTAE=N indicates that IMS should close the ACF/VTAM ACB immediately to expedite IMS termination, and leave affinity for all nodes set.

IMS VTAM generic resource logic in the IMS ESTAE exit attempts to delete generic resource affinity if no terminal status remains. This action requires a serial and synchronous VTAM CLSDST loop for all active terminals in IMS. Under normal conditions, the amount of time that this action requires is not significant. However, each CLSDST issued by the IMS ESTAE can incur the maximum defined VTAM I/O timeout time, leading to a significant delay in the final termination and subsequent restart of IMS.

Table 8 summarizes how generic resource affinities are managed based on whether affinities are VTAM or IMS managed and which GRESTAE options are indicated in the DFSDCxxx IMS.PROCLIB member.

*Table 8. Generic Resource Affinities Management and GRESTAE Options*

Affinity Manager	GRESTAE Option	Generic Resource Affinities Management
IMS	Y	IMS manages generic resource affinities, including during ESTAE processing.
		IMS resets affinity during the ESTAE process that occurs during IMS failure.
IMS	N	IMS manages generic resource affinities, except during ESTAE processing.
		IMS does not reset affinity during the ESTAE process that occurs during IMS failure.
VTAM	Y or N	VTAM manages generic resource affinities.

---

## Chapter 7. Managing TM Resources in an IMSplex

This chapter describes in detail the functions of the resource structure and Resource Manager (RM) as they relate to managing IMS Transaction Manager resources in an IMSplex.

The resource structure and RM are intended to run on IMS Version 8 or higher, in a DB/DC or DCCTL environment, and with CSL operating.

**Restriction:** The information in this chapter only applies to IMS Version 8 or higher. Although an IMSplex may include earlier versions, resource status recovery and name uniqueness enforcement does not apply to these earlier versions. Additionally, users or terminals moving between earlier versions and Version 8 will likely cause unpredictable results because resource status will be unavailable.

### **Related Reading:**

- For an introduction to global resource management, see “IMSplex Terminal Management” on page 17.
- For more information on administering an IMSplex with CSL, see *IMS Version 9: Administration Guide: System*.
- For information on resource-structure-related parameters for the DFSDCxxx PROCLIB member, see the *IMS Version 9: Installation Volume 2: System Definition and Tailoring*.
- For information on user exit routines DFSINSX0, DFSSGNX0, DFSINTX0, and DFSLGNX0, see the *IMS Version 9: Customization Guide*.
- For information about the Common Service Layer, which includes Resource Manager, see the *IMS Version 9: Common Service Layer Guide and Reference*.
- For detailed information about commands relating to the resource structure and RM, see *IMS Version 9: Command Reference*.

### **In this Chapter:**

- “Resource Name Uniqueness”
- “Resource Type Consistency” on page 130
- “Global Callable Services” on page 130
- “Transaction Manager Resources” on page 131
- “IMS Activities and RM” on page 134

---

## Resource Name Uniqueness

IMS ensures that a resource name is active only once in the IMSplex at any particular time. IMS systems within the IMSplex cannot activate the same resource at the same time. The IMSplex automatically enforces resource name uniqueness only when Resource Manager (RM) is active and a resource structure is defined in the coupling facility.

When a resource is active, it is owned by one IMS in the IMSplex. No other IMS can activate the same resource until it becomes inactive on the owning IMS.

Name uniqueness is enforced only for VTAM LTERMs (not BTAM LTERMs), VTAM single-session nodes, user IDs, and users.

## Resource Name Uniqueness

Name uniqueness is enforced for user IDs only if SGN is not M. User ID name uniqueness enforcement is not automatic. However, name uniqueness for VTAM LTERMs, VTAM single-session nodes, and users is automatically enforced if you have RM and a resource structure defined.

For ISC terminals, if the option for disabling resource sharing in the IMSplex is on in the DFSINTX0 user exit routine, resource name uniqueness is not enforced for static LU 6.1 sessions.

### Disabling Enforcement of Resource Name Uniqueness

You can disable the enforcement of resource name uniqueness, and TM resource sharing in general, by specifying `STM=NO` in the `DFSDCxxx` PROCLIB member.

**Related Reading:** See “Transaction Manager Resources” on page 131 for more detailed information about how and why IMS enforces name uniqueness for particular resources.

---

## Resource Type Consistency

Resource type consistency ensures that a name is unique within a group of resources, called a *name type*. The IMSplex automatically enforces resource type consistency when RM is active and a resource structure is defined in the coupling facility.

IMS enforces resource type consistency for the name type of message destination. IMS ensures that a resource defined as a message destination is consistent across the IMSplex.

Message destinations are the following:

- LTERMs
- LTERMs defined as APPC descriptors
- MSNAMEs
- Statically defined transactions
- CPI-C transactions

### Disabling Enforcement of Resource Type Consistency

You can disable the enforcement of resource type consistency when a resource structure is present by specifying `STM=NO` in the `DFSDCxxx` PROCLIB member. After specifying `STM=NO`, resource type consistency is enforced only for statically defined and CPI-C transactions.

**Related Reading:** See “Transaction Manager Resources” on page 131 for more detailed information about how and why IMS enforces type consistency for particular resources.

---

## Global Callable Services

Callable services are provided for user-provided exit routines in order to find resources such as nodes, LTERMs, and users. Callable services returns global resource information shared in the resource structure. If no global information is available, local information is returned by default.

If you want only local information, use the input flag `LOCAL` on the `CSCBLK` DSECT, which is defined by the `DFSCBLK` macro.



**Related Reading:** For more information on callable services, see *IMS Version 9: Customization Guide*.

---

## Transaction Manager Resources

Transaction Manager Resources are discussed in the following topics:

- “TM Resources: APPC Descriptors”
- “TM Resources: VTAM LTERMs”
- “TM Resources: MSNAMEs” on page 132
- “TM Resources: VTAM Terminal Nodes” on page 132
- “TM Resources: Transactions” on page 133
- “TM Resources: User Names” on page 133
- “TM Resources: User IDs” on page 134

### TM Resources: APPC Descriptors

IMS defines APPC descriptors to RM at initialization or during /STA LU62DESC to maintain resource type consistency for message destinations. IMS ensures that an APPC descriptor name is not used as a transaction, MSNAME, or LTERM name. Descriptors can be defined on multiple IMS systems as name uniqueness is not enforced.

#### APPC Descriptor Creation and Deletion

At initialization or during /STA LU62DESC, IMS ignores any descriptors already defined as a transaction, MSNAME, or LTERM and issues a warning message. APPC descriptors are deleted from RM when all IMS systems that have defined the descriptor have terminated, warm or cold. Systems that do not define the descriptor do not need to terminate.

### TM Resources: VTAM LTERMs

IMS defines VTAM LTERMs to RM for resource type consistency for message destinations, name uniqueness for LTERMs, and LTERM status recovery.

#### LTERM Name Uniqueness

IMS enforces name uniqueness for VTAM LTERM names to ensure output security within an IMSplex. When an LTERM becomes active, IMS ensures that the LTERM does not become active on any other IMS and is unavailable to any other user or terminal.

For LU 6.1 sessions, LTERM name uniqueness can be ignored by using the DFSINTX0 user exit routine. See *IMS Version 9: Customization Guide* for more information on this exit routine.

IMS does not enforce name uniqueness for BTAM LTERMs. Therefore, if an LTERM is assigned from a BTAM terminal to a VTAM terminal, name uniqueness is enforced when the terminal becomes active. Conversely, if an LTERM is assigned from a VTAM terminal to a BTAM terminal, name uniqueness stops being enforced. Because BTAM LTERM status is not kept in RM, multiple BTAM LTERMs with the same name—or a BTAM LTERM and a VTAM LTERM with the same name—can be active at the same time.

#### LTERM Creation and Deletion

When an LTERM becomes active during signon or logon, IMS defines it to the RM. If the name is the same as a transaction, APPC descriptor, or MSNAME, or if the

## Transaction Manager Resources

LTERM is active on another IMS, the LTERM does not become active. The signon of a dynamic user continues without an LTERM assigned (but if there is only one LTERM, the signon is rejected), and the logon for a static terminal is rejected. IMS also defines LTERMs to RM when recoverable commands affecting significant status are processed.

When an LTERM becomes inactive and there is no significant status data, IMS deletes the LTERM. An LTERM is deleted in three situations:

- During a logoff or signoff
- When a command deleting significant status is processed
- During resource cleanup after an IMS failure and no significant status exists

### TM Resources: MSNAMES

MSC networks use MSNAMES to define remote IMS systems and logical link paths between remote and local IMS systems in an MSC network. For MSNAMES, Resource Manager (RM) enforces only resource type consistency for message destinations, but not resource name uniqueness. When IMS initializes, IMS defines to RM each MSNAME that has a remote SYSID. Because resource name uniqueness is not enforced, the same MSNAMES can be defined on multiple IMS systems.

#### Creation and Deletion of the MSNAME TM Resource

An MSNAME becomes a TM resource to RM at IMS initialization. RM saves the MSNAME in the resource structure. MSNAMES are not deleted from a resource structure once they are defined and cannot be reused unless the resource structure itself is deleted.

**Related Reading:** For additional information on MSNAMES and how they are used in a shared resources group, see “MSNAME Duplication in an IMSplex with Shared Queues” on page 243.

### TM Resources: VTAM Terminal Nodes

IMS defines nodes to RM to enforce name uniqueness for single-session VTAM terminals and to recover node status.

#### Node Name Uniqueness

IMS enforces name uniqueness of VTAM terminals to ensure only one terminal can be logged on at one time and to ensure data integrity. These terminals include all VTAM terminals except LU 6.1 (ISC) parallel sessions.

IMS does not enforce name uniqueness for LU 6.1 parallel sessions, but data integrity is ensured by user name uniqueness. For LU 6.1 sessions, node name uniqueness can be ignored by using the DFSINTX0 user exit routine. See *IMS Version 9: Customization Guide* for more information on this exit routine.

**Note:** Some session manager products that assign non-unique ETO node names to terminals logging onto multiple systems in an IMSplex will not work properly with RM. IMS prevents the same non-ISC node name from being active in more than one system at a time.

#### Node Creation and Deletion

IMS defines a node to RM when the node becomes active during terminal logon. Logon is rejected if the node is already active on another IMS system, except for ISC parallel sessions. IMS also defines a node to RM when recoverable commands

that process significant status are processed. These commands include the commands that set global MFSTEST, STOP, and TRACE.

When a node becomes inactive and there is no significant status data, IMS deletes the node. A node is deleted in three situations:

- During logoff
- When a command deleting significant status is processed
- During resource cleanup after an IMS failure and no significant status exists

### TM Resources: Transactions

IMS defines a transaction statically in the system where the application will run or dynamically as a CPI-C transaction executed by an APPC conversation. A transaction can run in multiple systems concurrently as name uniqueness is not enforced.

Within the context of TM resource management, transactions are treated as a resource only to prevent another TM resource from duplicating the transaction name. RM continues to prevent the duplication of transaction names even if you disable TM resource sharing by specifying STM=NO in the DFSDCxxx PROCLIB member.

#### Transaction Resource Type Consistency

IMS ensures that a transaction name cannot be used as an MSNAME, APPC descriptor, or an LTERM name. IMS ignores a CPI-C transaction if the name is defined as a different message destination. APPC still validates the destination and does not allow LTERMs as destinations.

#### Transaction Creation and Deletion

IMS statically defines a transaction to RM when IMS initializes and when online change adds a transaction. IMS terminates during initialization if the name is already defined in the IMSplex as another resource.

IMS identifies a CPI-C transaction to RM during APPC input processing and after it checks to make sure the name is not defined as another message destination already. If it is defined as another resource, IMS uses the defined destination and no error is generated.

Cold-starting an IMS does not delete a transaction.

### TM Resources: User Names

The user name and the user ID are usually the same; however, user exits and descriptors can override the user name. The *user* is the user signed on to a dynamic terminal or parallel session subpool and has associated work and status. The *user ID* identifies a person signed on to a terminal for security authorization by a security product such as RACF.

#### User Name Uniqueness

IMS enforces name uniqueness for user names to ensure data integrity for users. Users are defined to RM during user signon or ISC session initiation. If the user is already active, IMS rejects the signon or session initiation.

For ISC sessions, user name uniqueness can be ignored by using the DFSINTX0 user exit routine. See *IMS Version 9: Customization Guide* for more information on this exit routine.

### User Creation and Deletion

When a user becomes active during user signon, IMS defines it to the RM. If the user is active on another system, signon is rejected. IMS also defines users to RM when recoverable commands affecting significant status are processed.

IMS deletes the user from RM when the user becomes inactive and no significant data exists. A user is deleted in three situations:

- During user signoff
- When a command deleting significant status is processed
- During resource cleanup after an IMS failure and no significant status exists

### TM Resources: User IDs

The *user ID* identifies a person signed on to a terminal for security authorization by a security product such as RACF. The user ID and the user name are usually the same, but see “TM Resources: User Names” on page 133 for an example of when they are not the same.

#### User ID Name Uniqueness

You can decide whether to enforce name uniqueness for user IDs. The default is to enforce user ID name uniqueness. If you want one user ID to be able to sign on to multiple terminals at a time (name uniqueness not enforced), use the IMS startup parameter `SGN=M`.

#### User ID Creation and Deletion

When a user signs on to a terminal and single-signon enforcement is requested, IMS defines the user ID to RM. Once a user is signed onto a VTAM terminal in the IMSplex, any signon attempt by that user is rejected. When a user ID becomes inactive, IMS deletes it from RM. A user ID is deleted in two situations:

- During user signoff
- During resource cleanup after an IMS failure

---

## IMS Activities and RM

This topic details the effects of RM and the resource structure on some IMS activities.

### Conversations

Conversation status is shared within the IMSplex, and so the conversation's IDs must be unique for individual dynamic users or static nodes. To uniquely identify a conversation, qualify the conversation with the associated input LTERM.

To display conversation status, use the `/DISPLAY CONVERSATION` command for local and RM conversation information.

### Initialization

IMS enforces consistency of single signon, `SGN=M`, in the startup parameters when RM and a resource structure are active. The first IMS active in the IMSplex sets the value for the entire IMSplex. If an IMS joins an IMSplex with a different value for single signon, IMS issues a warning message and uses the IMSplex value. You can change the specification when all the IMS systems leave and then rejoin the IMSplex (warm start). You can override the value by using the `/NRE` or `/ERE` commands.

During a warm start, when RM is active, the global signon value comes from the startup parameter of the first IMS to join the IMSplex. The signon value comes from the checkpoint log records when RM is inactive during the warm start.

### Shutdown

When an IMS system shuts down, all non-recoverable status owned by the system is deleted from the resource structure. SCI notifies the other IMS systems that the IMS is leaving because of either a normal or abnormal shutdown.

When an IMS system shuts down abnormally, another IMS in the IMSplex becomes the cleanup IMS. This IMS requests a list of resources without significant status. If a resource does have significant status and the resource recovery mode is GLOBAL, the owner is cleared and the resource becomes available to other systems. If the recovery mode is LOCAL, affinity for the failed system is enforced.

### Checkpoint

Because terminal and user status are maintained by RM, if active, local DC control blocks must be cleaned up and deleted during IMS checkpoint if they are inactive. Checkpoint deletes local status in local blocks with GLOBAL status recovery mode. Checkpoint maintains status in local blocks with LOCAL status recovery mode.

These recovery modes are treated the same way during a simple checkpoint after a warm or emergency restart. However, if a resource is in LOCAL status recovery mode, DFSSGNX0 and DFSLGNX0 can request that another IMS steal the resource that is owned by the failed IMS system. In that case, the restarting IMS deletes the local status during its restart.



---

## Part 3. Extended Terminal Option

### Chapter 8. Overview of the Extended Terminal Option

Benefits of Using ETO . . . . .	139
ETO Terminology . . . . .	140
Terminals. . . . .	140
Dynamic Users . . . . .	140
Terminal and User Structures . . . . .	140
Descriptors . . . . .	142
ETO Concepts . . . . .	143
When Structures Are Created and Deleted. . . . .	143
Descriptors and Exit Routines . . . . .	144
How Descriptors Are Created and Used . . . . .	144
Summary of ETO Implementation . . . . .	145

### Chapter 9. Administering the Extended Terminal Option

Planning for ETO . . . . .	148
Identifying Your Requirements . . . . .	148
Restrictions on ETO . . . . .	149
Defining Physical Terminals . . . . .	149
Identifying VTAM Device Types, Screen Sizes, and Models . . . . .	152
Planning a High-Security Environment with ETO . . . . .	157
Planning for MFS . . . . .	158
Planning User IDs . . . . .	159
Planning User Queue Names . . . . .	159
Planning Operations . . . . .	159
Planning for MSC Support with ETO . . . . .	160
Coding ETO Descriptors. . . . .	160
Creating Descriptors Using the System Definition Process . . . . .	161
Storing Descriptors . . . . .	161
Creating Logon Descriptors . . . . .	161
Creating User Descriptors . . . . .	165
Creating MFS Device Descriptors. . . . .	168
Creating MSC Descriptors . . . . .	171
Exit Routines . . . . .	172
Starting ETO . . . . .	172
Logging onto ETO Terminals . . . . .	173
Limiting Dynamic Logon To Specific Terminal Types . . . . .	173
Creating and Reusing LTERM Control Blocks Using Default CINIT or BIND User Data Formats . . . . .	174
Signing On and Queue LTERM Allocation. . . . .	175
Providing Signon Data . . . . .	175
Providing Signon Data for ISC, SLU-P, Finance, and Output-Only Devices . . . . .	175
Signing On Multiple Times. . . . .	175
Receiving the Signon Required Message—DFS3649A . . . . .	177
Receiving the Session Status Message—DFS3650 . . . . .	177
ETO Terminal-LTERM Relationship . . . . .	177
How IMS Determines Which Queues to Allocate . . . . .	178
Setting Special Processing Modes. . . . .	178

Printers with ETO . . . . .	179
Direct Printing . . . . .	179
Associated Printing . . . . .	179
Defining Your Printers . . . . .	181
Sharing Printers Using ETO . . . . .	181
Operator Commands . . . . .	182
/OPNDST . . . . .	182
/ASSIGN. . . . .	182
System Definition Parameters for ETO . . . . .	182
Setting DEADQ Status Time with the DLQT Parameter . . . . .	182
Autosignoff (ASOT) . . . . .	183
Autologoff (ALOT) . . . . .	184
Autosignoff and Autologoff Timer . . . . .	186
Autologon . . . . .	186
Assigning Output . . . . .	187
Asynchronous Output . . . . .	187
Delivering Output Messages to Non-Originating Terminals. . . . .	188
Inadvertent Output Data Streams. . . . .	189
Signing Off . . . . .	189
Logging Off . . . . .	189
Improving Performance by Deleting ETO Control Blocks . . . . .	189
IDC0 Trace Facility . . . . .	190
ETO and LU 6.1 (ISC) Terminals . . . . .	190
ETO and STSN Terminals . . . . .	191
SNA STSN Terminal Considerations. . . . .	191
ETO and 3600/Finance and SLU P . . . . .	192
/SIGN Support for ETO STSN Devices: ISC, Finance, and SLU P . . . . .	192
Conversation Mode and Response Mode with ETO . . . . .	193
Conversation Mode . . . . .	193
Response Mode . . . . .	193





---

## Chapter 8. Overview of the Extended Terminal Option

This chapter introduces the IMS Extended Terminal Option (ETO). ETO allows you to add VTAM terminals and users to your IMS without predefining them during system definition. ETO is part of the IMS Transaction Manager (TM), and provides additional features for users, such as output security, automatic logoff, and automatic signoff.

This chapter provides system programmers with the conceptual information that is required to implement and administer ETO. Read the information in this chapter if you are unfamiliar with ETO. Then, proceed to Chapter 9, “Administering the Extended Terminal Option,” on page 147 to understand the tasks associated with administering ETO in your environment.

### **In this Chapter:**

- “Benefits of Using ETO”
- “ETO Terminology” on page 140
- “ETO Concepts” on page 143

---

## Benefits of Using ETO

ETO adds essentially two major enhancements to the Transaction Manager environment. With ETO:

- Users can obtain IMS sessions with VTAM terminals that have not been defined to IMS during system definition.
- Output messages that are destined for particular users are secure, and they reach only those users.

In addition, by installing ETO, you can achieve each of the following:

- Improved system availability by reducing scheduled down time associated with adding or deleting VTAM terminals.
- Faster system availability to users, because they can establish an IMS session from any VTAM terminal in the network.
- Improved IMS security by relating output messages to users, rather than to terminals.
- Reduced number of macros required to define the terminal network. This reduces system definition time and storage requirements.
- Reduced checkpoint and restart time. For ETO terminals and user structures, resources are not allocated until they are actually required; similarly, when they are no longer required, they are deleted.
- Reduced number of skilled system programmer resources that are required for maintaining static terminal definitions.

### **Related Reading:**

- For more information on user structures, see “User Structures” on page 140.
- For more information on static terminals, see “Terminals” on page 140.

### ETO Terminology

The following terms have ETO-specific meanings that are important for understanding and administering ETO:

- “Terminals”
- “Dynamic Users”
- “Terminal and User Structures”
- “Descriptors” on page 142

### Terminals

The definitions for terminal, static terminal, and dynamic terminal are described in this topic.

#### Definitions:

- A *terminal* is a physical VTAM logical unit (LU) that establishes a session with IMS. A physical terminal is represented using a control block.
- When terminals are not built by ETO but are defined at system definition, they are called *static terminals*. A static terminal can be a VTAM node or a BTAM line. When messages are sent to a static terminal they are queued to a logical terminal (LTERM) message queue, where they await retrieval by the recipient.
- When a terminal is not defined at system definition and ETO builds a terminal, that terminal is called a *dynamic terminal*, or an *ETO terminal*. For dynamic terminals, the logical terminal (LTERM) is known as a *dynamic user message queue*, LTERM associates the messages with the user, rather than with the physical terminal. Associating messages with the users provides more security for these users, because they can access their messages only when they sign on using their unique user ID. In addition, all users in the network can access their messages from any physical terminal, instead of being restricted to using a particular physical terminal.

### Dynamic Users

**Definition:** An ETO *dynamic user* is a user who signs on to a dynamic terminal and who has a unique identification (user ID) that IMS uses for delivering messages. The user is usually associated with a person but can also be associated with another entity, such as a printer.

### Terminal and User Structures

**Definition:** A *terminal or user structure* is an IMS control block that represents terminals and users in ETO.

#### Terminal Structures

A *terminal structure* is a control block that represents a specific terminal that is known to IMS. A terminal structure is created when the individual terminal logs on to IMS. It is deleted when the terminal logs off with no remaining associated activity (such as status that must be retained for the next connection to IMS).

#### User Structures

A *user structure* is a set of control blocks, including a user block and one or more LTERM blocks. The message queues are associated with the dynamic user, as opposed to the physical terminal, and they are queued to the user ID.

The dynamic user structure connects to the physical terminal only when the user signs on. This provides a secure environment, because different users accessing the same terminal cannot receive each other's messages.

IMS creates a user structure when either of the following events take place:

- A dynamic user signs on to IMS.
- Output messages that are destined for a dynamic user are sent to the user, but the user has not signed on to IMS.

Usually, a user structure represents a person who uses IMS. The user structure name is usually the same as the user ID. A user structure can also represent a logical destination, such as a printer. In this case, the user structure name can be the same as or different from the LTERM name that your installation uses in its application programs and its exit routines. For example, you can assign the same name to a user structure for a printer that you assign to its LTERM destination node name. However, output is then queued according to the terminal, and not to the user.

Figure 21 and Figure 22 on page 142 show the differences between static resources and ETO dynamic resources.

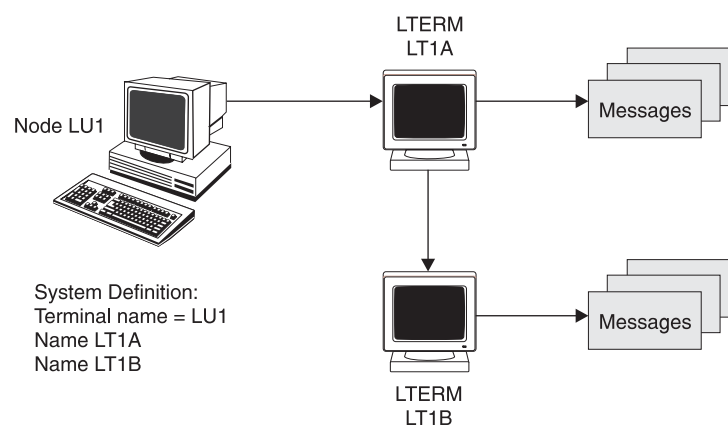

Figure 21. Static Resources

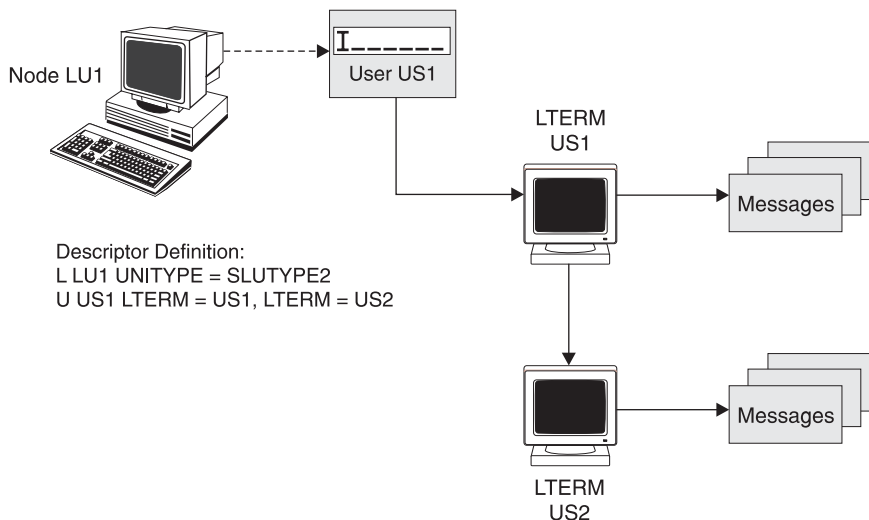

Figure 22. ETO Dynamic Resources

## Descriptors

**Definition:** A *descriptor* provides information to IMS when IMS builds a dynamic resource for a logon or a signon.

The four types of ETO descriptors are:

- Logon descriptors
- User descriptors
- MSC descriptors
- MFS device descriptors

IMS stores descriptors in three IMS.PROCLIB members:

- DFSDSCMx** Contains the descriptors that are automatically generated during IMS system definition. The suffix of DFSDSCMx matches the suffix that your installation specifies on the SUFFIX= parameter of the MSGEN system definition macro.
- DFSDSCTy** Contains customized device descriptors that your installation creates. Descriptors in DFSDSCTy override duplicate descriptors in DFSDSCMx, and the last descriptor that is defined is used.
- DFRSRxx** Specifies the RSR options used by the online active and tracking subsystems. IMS batch jobs do not use the DFRSRxx member.

### Logon Descriptor

**Definition:** A *logon descriptor* is a skeleton that IMS uses to build an ETO dynamic terminal. It provides information regarding a terminal's physical characteristics. IMS uses logon descriptors in conjunction with exit routines to create terminal structures.

The three types of logon descriptors are: generic, group, and specific.

#### Definitions:

- A *generic logon descriptor* provides characteristics for all terminals of a particular type. For example, all SCS printers might share a single generic descriptor. Similarly, all 3270 terminals might share a generic descriptor.
- A *group logon descriptor* provides characteristics for a collection of terminals, each of which has compatible hardware characteristics and is defined to IMS in the same manner. The actual characteristics for these terminals are usually identical, but they can differ; IMS uses the group descriptor to derive their characteristics.  
**Example:** You might create separate logon descriptors for different groups of terminals that differ only in the setting for the autologoff (ALOT) time value.
- A *specific logon descriptor* provides characteristics for a single terminal, and these characteristics apply only to that terminal. In this case, the descriptor name matches the name of the terminal that it describes.

**Recommendation:** Although you might need to use specific logon descriptors during the actual migration to ETO, use generic or group logon descriptors after you have migrated to ETO; these kinds of descriptors ease network administration.

### User Descriptor

**Definition:** A *user descriptor* is a skeleton from which a user structure is built. A user descriptor can provide user options and queue names.

### MSC Descriptor

**Definition:** An *MSC descriptor* is used to create a remote LTERM, which is an LTERM that does not exist on the local IMS. The physical terminal definition (either static or dynamic) for the remote LTERM is in the remote IMS.

Each MSC descriptor for a remote LTERM is loaded during IMS initialization and tells IMS which MSC link to use for output destined for that remote LTERM.

**Related Reading:** For more information on MSC, see Chapter 10, “Overview of Multiple Systems Coupling,” on page 197.

### MFS Device Descriptor

**Definition:** *MFS device descriptors* allow you to add new device characteristics for MFS formatting without requiring an IMS system definition. The MFSDCT utility (DFSUTB00) uses MFS device descriptors to update default formats in the MFS library.

IMS also uses MFS device descriptors to update the MFS device characteristics table. IMS loads this table only during initialization; therefore, updates are not effective until the next IMS initialization.

---

## ETO Concepts

This topic describes important ETO concepts. If you are not familiar with ETO, be sure to read this topic before proceeding to Chapter 9, “Administering the Extended Terminal Option,” on page 147.

### When Structures Are Created and Deleted

Structures are created in the following situations:

- Log on
- Sign on
- Output is queued to your LTERM
- /ASSIGN command is used to assign an LTERM to a non-existent user

## ETO Concepts

- /ASSIGN command is used to assign a non-existent LTERM to a user
- /CHANGE USER *username* AUTOLOGON command is directed to a non-existent user

In all cases, IMS searches for an existing structure (terminal or user) before creating a new one.

IMS creates and deletes user structures in the following sequence:<sup>7</sup>

1. When you establish a session between IMS and an undefined terminal, IMS selects a logon descriptor.
2. Using the information in the logon descriptor, the customization defaults, and VTAM information, IMS builds a VTAM terminal control block that describes the new terminal.
3. When you sign on, if a user structure does not exist, IMS builds one, using information from a user descriptor that it selects, and then connects this user structure to the terminal structure.
4. IMS deletes terminal or user structures when they are no longer needed to maintain sessions. User structures are typically deleted when you sign off, if no special status needs to be maintained and if no messages remain queued. IMS deletes terminal structures when no terminal status exists (such as trace mode), no user is signed on, and the terminal is idle.

If you are using Resource Manager and a resource structure, IMS normally maintains status in the resource structure instead of the local control blocks. Therefore, IMS deletes the structures.

**Exceptions:** The following terminal structures and user structures are not deleted:

- SLU P and Finance terminal and user structures are normally only deleted during IMS coldstart if SRM=LOCAL. They can also be deleted, however, if the /CHANGE NODE COLDSESS command is used, in which case they are deleted at the first checkpoint following the command.
- ISC terminal and user structures are only deleted following a cold session termination if SRM=LOCAL.

## Descriptors and Exit Routines

The main purpose of ETO is to dynamically define terminals to IMS. Using descriptors and exit routines, you can assign characteristics to these dynamic terminals and assign user structures to be associated with those terminals.

A descriptor provides the basic information for the dynamic terminal. An exit routine completes or changes this information. Two methods of using descriptors and exit routines are:

- You can use many descriptors and code little or no processing logic in exit routines.
- You can use few descriptors and code exit routines to perform much of the processing.

## How Descriptors Are Created and Used

All descriptors are created during IMS initialization, prior to IMS startup. You must specify that you want ETO support and ensure that the ETO initialization exit routine (DFSINTX0) does not disable ETO support.

---

7. This sequence applies only to terminal logon and logoff and to user signon and signoff. When asynchronous output is queued to a user, IMS creates the user structure, as needed.

During IMS initialization, IMS reads and validates all ETO descriptors. IMS initialization then continues, and the descriptors remain in storage for the duration of IMS execution. Any changes you make to descriptors become effective after the next initialization of IMS.

IMS uses descriptors to create both terminal and user structures. IMS rebuilds structures during an IMS restart, if appropriate. For example, if messages are queued for a structure and IMS goes down, the structures are rebuilt when IMS restarts. IMS rebuilds these structures to be the same as they were before the IMS restart. IMS does not use the descriptors or exit routines to rebuild these structures. Therefore, any changes you make to descriptors are only reflected in new structures that are built after IMS restart, and the changes are not reflected in structures that are rebuilt during IMS restart.

**Example:** USERA signs on using descriptor DESCa which specifies ASOT=20. USERA starts an IMS conversation, and then IMS abnormally terminates. The system programmer changes DESCa to ASOT=10. After the IMS restart, USERB signs on using DESCa. USERA was rebuilt during the IMS restart. USERA still has ASOT=20, and USERB has ASOT=10.

## Summary of ETO Implementation

Figure 23 illustrates the concepts covered in this chapter and shows an overall view of an ETO implementation.

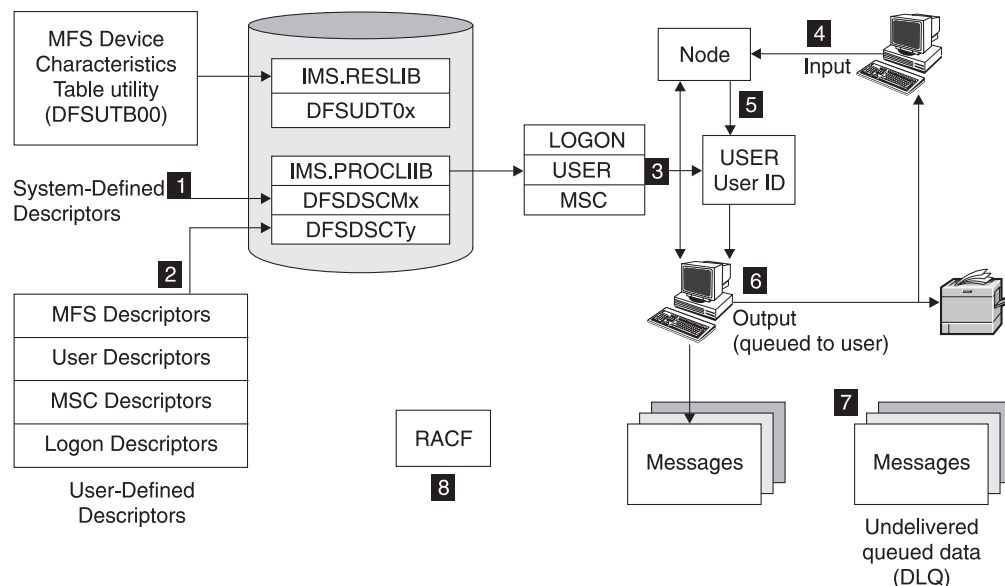

Figure 23. Summary of ETO Implementation

- **1** The system-defined descriptors that are built during system definition are stored in IMS.PROCLIB as member DFSDSCMx.
- **2** Your user-defined descriptors that are written to override the system definition defaults are stored in IMS.PROCLIB as member DFSDSCTy. MFS descriptors that are processed by the MFS Device Characteristics Table utility (DFSUTB00) are stored in the device characteristics table.
- **3** Logon, user, and MSC descriptors are loaded at IMS initialization using the input from IMS.PROCLIB.
- **4** The Logon and Logoff exit routines are called during logon and logoff.

## ETO Concepts

- **5** The Signon and Signoff exit routines are called during signon and signoff.
- **6** Output is delivered to the destination specified in the Output Creation exit routine, unless the user is created during signon.
- **7** If IMS is unable to determine where output should be delivered, the messages are added to the dead-letter queue. Messages might not be delivered because:
  - The user name is not a valid user ID.
  - The user signon is rejected.
  - A physical-to-logical relationship does not exist between the device and the LTERM.
- **8** RACF (or an equivalent product) manages security in the ETO environment.



---

## Chapter 9. Administering the Extended Terminal Option

The IMS Extended Terminal Option (ETO) allows you to dynamically add VTAM terminals and users to your IMS without having to first define them during system definition. ETO dynamically creates user structures for a terminal session when:

- The user signs on to IMS.
- Output messages are sent to the user and await retrieval by the user.
- The /ASSIGN command is used to assign an LTERM to a non-existent user.
- The /ASSIGN command is used to assign a non-existent LTERM to a user.
- The /CHANGE USER *username* AUTOLOGON command is directed to a non-existent user.

Some of the administrative advantages of using ETO include:

- You do not need to code the following macros for the system definition stage-1 input stream:
  - MSC remote NAME macros
  - VTAM macros: TYPE, TERMINAL, NAME, VTAMPOOL, SUBPOOLRemoving these macros reduces the complexity of network management.
- You need to perform fewer system definitions.
- You schedule fewer planned outages for new system definitions.

### **In this Chapter:**

- “Planning for ETO” on page 148
- “Coding ETO Descriptors” on page 160
- “Exit Routines” on page 172
- “Starting ETO” on page 172
- “Logging onto ETO Terminals” on page 173
- “Signing On and Queue LTERM Allocation” on page 175
- “Printers with ETO” on page 179
- “Operator Commands” on page 182
- “System Definition Parameters for ETO” on page 182
- “Assigning Output” on page 187
- “Signing Off” on page 189
- “Logging Off” on page 189
- “Improving Performance by Deleting ETO Control Blocks” on page 189
- “IDC0 Trace Facility” on page 190
- “ETO and LU 6.1 (ISC) Terminals” on page 190
- “ETO and STSN Terminals” on page 191
- “Conversation Mode and Response Mode with ETO” on page 193

Using ETO, you can ensure that all terminals and users are able to establish sessions with IMS, even if these terminals and users are not defined to IMS during system definition. You can use execution-time parameters and exit routines to authorize users to access some or all of the functions that ETO provides.

### **Related Reading:**

## Administering the Extended Terminal Option

- For information on specific device types that IMS supports, see *IMS Version 9: Release Planning Guide*.
- For information on using execution parameters, see *IMS Version 9: Administration Guide: System*.
- For information on using exit routines, see *IMS Version 9: Customization Guide*.

---

## Planning for ETO

This topic provides planning information to help you migrate your current static-terminal environment to an ETO environment.

Although you can continue to define VTAM terminals and LTERMs to IMS during system definition, if you do so:

- You cannot take advantage of the ETO features that exist for those terminals.
- You must fully define the terminal. You must supply all TERMINAL macros, NAME macros, and parameters.

ETO terminals must be VTAM terminals.

**Restrictions:** The following VTAM terminals cannot be ETO terminals:

- IMS master terminal (MTO)
- IMS secondary master terminal
- MSC physical and logical links
- ISC sessions that are used by XRF for surveillance
- LU 6.2 terminals (dynamically created and managed by APPC/IMS)

## Identifying Your Requirements

ETO is considered fully implemented when no static VTAM terminals exist in the system and when the majority of terminals and users are defined using the default logon descriptor and default user descriptor. However, because installations vary in application program dependencies, the cost of fully implementing ETO also varies.

Your installation should determine the extent to which full ETO support is required, based on the following requirements:

### Full user-message security

Full implementation of ETO is required for full user-message security. In this environment, no node-name user descriptors exist. Any requirements for user structures that the default user structure does not provide must be defined by user descriptors or by the Signon exit routine (DFSSGNX0).

### Dynamic terminal support only

Only partial implementation is required for dynamic terminal support. You can move network definition statements from the system definition to ETO descriptor PROCLIB members. Benefits of this implementation include:

- Fewer system definitions are required in order to maintain network definitions, because you can change descriptors between IMS warm starts.
- Shorter run times are required for system definition, because you do not need to define VTAM terminal networks.

- Improved performance exists for IMS checkpoint and restart, because dynamic terminals and user resources are allocated only when they are used.

With partial implementations, however, you do not achieve improved user-message security, because each LTERM has a fixed relationship with a physical terminal.

### Restrictions on ETO

Before implementing ETO, be aware of the following restrictions:

- ETO dynamic terminals do not support the Security Maintenance utility (SMU).
- Dynamic terminals are not supported for terminal-related MSDBs or for non-terminal-related MSDBs that have LTERM keys.
- Application programs that use specific LTERM names sometimes require particular ETO customization.

**Related Reading:** For more information on how to customize ETO for application programs that have dependencies on LTERM names contained in the I/O PCBs, see “Using DFSUSER User Descriptors” on page 167.

### Defining Physical Terminals

When implementing ETO, ensure you achieve your desired VTAM terminal network by taking each of the following actions:

- Assess how often IMS application programs depend on specific terminal characteristics.
- Check the accuracy of each VTAM terminal definition. For each dynamic terminal, ETO builds a terminal structure that relies on the VTAM definition for the characteristics (such as the LU type, screen size, and model) for that terminal.

Terminal characteristics that are specified in your IMS system definition might differ from (and override) those in the VTAM definitions. If these terminal characteristics in the IMS system definition are compatible with those of the actual terminal, the discrepancy is not apparent.<sup>8</sup>

- Either provide specific node-name logon descriptors or use the Logon exit routine (DFSLGNX0) for terminals that are not adequately defined using the default logon descriptor.
- Code one of the following two exit routines to determine the device type:
  - The Logon exit routine (DFSLGNX0) can determine the device type by examining the default logon descriptor.
  - The Signon exit routine (DFSSGNX0) can determine the device type later in the process by examining the terminal control blocks.

When receiving a request to establish a terminal session, IMS relies on the following information from VTAM session parameters:

- **UNITYPE**

The unit type of the node that is attempting to log on. IMS determines the UNITYPE by using the following fields:

---

8. If the actual terminal characteristics do not match those in the IMS definition or the VTAM definition, it is possible that the terminal can function with IMS.

- The LUTYPE field of the CINIT<sup>9</sup> request provides part of the UNITYPE information. The LUTYPE value is usually found in the first byte of the PSERVIC operand of the MODEENT macro, which is used to generate the VTAM mode table entry that is used for a logon. Figure 24 shows the fields of the PSERVIC operand in the VTAM MODEENT macro.

Table 9 shows the mapping of the LUTYPE value to the IMS UNITYPE.

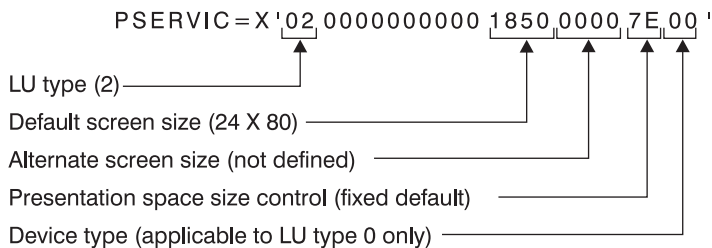

Figure 24. VTAM MODEENT Macro PSERVIC Operand Fields that IMS Uses

Table 9. Mapping for VTAM LUTYPE Value to IMS UNITYPE

VTAM LUTYPE	IMS UNITYPE
LUTYPE X'06'	LUTYPE6
LUTYPE X'02'	SLUTYPE2
LUTYPE X'01'	SLUTYPE1 (default) or NTO
LUTYPE X'00'	3270, SLUTYPEP, or 3600/Finance

- If the LUTYPE field is X'00' (indicating that the terminal is 3270 non-SNA, Finance, or SLU P), IMS must check the transmission services profile specification in the TS field of the CINIT request. The TS value is usually found in the TSPROF operand of the MODEENT macro that is used to generate the VTAM mode table. This LUTYPE value must match the value in the logon descriptor that IMS selects for a logon.

Table 10 shows the mapping of the TSPROF specification to the IMS UNITYPE.

Table 10. Mapping for TSPROF Specification to IMS UNITYPE

TSPROF Specification	IMS UNITYPE
X'02' or X'03'	3270
X'04'	SLUTYPEP (default) or 3600/Finance

- **Input RU size**

The input RU (request unit) size in the BIND must be less than or equal to the RECANY buffer size for the IMS (also required for static terminals).

- **Output RU size**

The output RU size in the BIND must be greater than or equal to the OUTBUF size that IMS determines for the terminal from the selected logon descriptor. This parameter is also required for static terminals.

- **Screen size and model number**

For non-SNA 3270 and SLUTYPE2 devices, IMS retrieves both screen size (row and column) and model number from the BIND:

9. CINIT is a network services request sent from a system services control point (SSCP) to a logical unit (LU), asking that LU to establish a session with another LU and to act as the primary end of the session.

- For static terminals, the screen size is the value that was specified in the system definition.
- For dynamic terminals, IMS determines the screen size from the VTAM definition or from the Logon exit routine (DFSLGNX0).

**Recommendation:** Until the ETO feature was available, IMS ignored the screen size and model number values in the BIND, because the IMS system definition held this information. Therefore, check to ensure this definition is accurate.

If you determine that a VTAM definition is inaccurate, you can use the Logon exit routine (DFSLGNX0) to override the VTAM-provided screen size and model number. For example, use a terminal naming convention or MODETAB definition convention. The Logon exit routine can also assign USER=NODE as a name, when appropriate.

IMS uses the values in the PSERVIC operand of the MODEENT macro, which is used to generate the VTAM mode table entry that is used for a logon. MFS formats must be available for all screen sizes that IMS dynamically builds.

**Restriction:** IMS does not use the 3270 Read Partition Query (RPQ) command to determine the screen size from the device controller.

### **Related Reading:**

- For more information on the PSERVIC operand values for screen size and model numbers, see “Identifying VTAM Device Types, Screen Sizes, and Models” on page 152.
- For more information on the Logon exit routine (DFSLGNX0), see *IMS Version 9: Customization Guide*.

## **Planning for Both Static and Dynamic Terminals**

Static and dynamic terminals can coexist in the same IMS. However, if users move between static and dynamic terminals, plan for the following situations:

- IMS maintains separate queues for static and dynamic terminals. A static terminal has one or more LTERMs associated with it, as controlled by the IMS system definition (or the /ASSIGN command to move an LTERM to a different terminal). Some users become accustomed to having their output queue follow them from ETO terminal to ETO terminal. Static terminals do not provide this feature. Users need to be able to differentiate between static and dynamic terminals, or confusion can result.
- Given one static terminal and one dynamic terminal, separate IMS conversations can exist at the same time. The dynamic terminal conversation belongs with the user structure and follows the user from terminal to terminal.<sup>10</sup> The static conversation belongs to the static terminal and can only be released to a static terminal. This situation is user friendly and predictable only when the user is certain of the terminal type (static or dynamic).

Normally, the terminal operator is able to determine whether a terminal is static or dynamic by checking the security information that is provided at the end of the DFS3650 (SESSION STATUS) message:

### **OUTPUT SECURITY AVAILABLE**

Indicates that the terminal is dynamic, and output is associated with the signon ID.

---

10. This assumes that the Signon exit routine (DFSSGNX0) sets the same user name each time, as is usually the case.

## Planning for ETO

### **NO OUTPUT SECURITY AVAILABLE**

Indicates that the terminal is either statically defined or that ETO created it by using one of two methods:

- Using a node user descriptor
- Using the Signon exit routine to assign the node name to the user structure

In either case, the output is associated with the terminal, rather than with the user.

**Exception:** Message DFS3650 might be suppressed if you use the NOTERM option.

**Recommendation:** To ease migration and limit possible confusion, convert to dynamic ETO terminals by using logical groupings within your organization, such as departments or floors.

### **Defining Terminals for Growth**

When designing your ETO implementation, be sure to plan for growth in your network.

#### **Recommendations:**

- To increase future growth potential and system availability, minimize the use of descriptors. The Logon, Signon, and Output Creation exit routines should provide enough customization, thereby eliminating the need for unique descriptors beyond those that are required for specific terminal types.
- To ensure user data is correctly handled, design exit routines carefully. In particular, carefully plan for user data that is specified during the logon process. Exit routines should work correctly, regardless of whether user data is specified. Some terminal types, such as Finance and SLU P terminals, require user data that specifies signon information. If this data is missing, the equivalent information must be provided in the Logon exit routine (DFSLGNX0).

#### **Related Reading:**

- For more information on the Logon exit routine (DFSLGNX0), Signon exit routine (DFSSGNX0), and Output Creation exit routine (DFSINSX0), see *IMS Version 9: Customization Guide*.
- For more information on migrating static VTAM terminals to ETO terminals, see "Identifying VTAM Device Types, Screen Sizes, and Models."

## **Identifying VTAM Device Types, Screen Sizes, and Models**

VTAM logon CINIT user data provides IMS with information to build session control blocks. This information must be accurate to ensure that the correct terminal-related control blocks is built from information in the logon descriptors. Carefully define your VTAM PSERVIC parameters to ensure that IMS selects the appropriate logon descriptors and establishes screen sizes using specific terminal characteristics.

The BIND is rejected if the input and output RU sizes in the BIND are incompatible with the IMS RECAN Y and descriptor OUTBUF sizes.

### **Defining Device Types**

IMS dynamic terminal control blocks are built from a combination of the following:

- The logon descriptor

- Information that VTAM passes to IMS during logon
- The MFS device characteristics table

If the definitions are coded incorrectly, IMS chooses the wrong MFS format and device characteristics, possibly causing screen format errors.

VTAM passes the physical terminal characteristics to IMS. The following fields have information that IMS uses to determine device types:

- LUTYPE field from the VTAM PSERVIC parameter of the VTAM MODEENT macro
- TS profile from the TSPROF parameter of the VTAM MODEENT macro

**Non-SNA 3270 Printers and Displays:** The default descriptor names for non-SNA 3270 printers and displays are DFS327P and DFS3270.

Rules required for defining non-SNA 3270 devices are:

- The TSPROF parameter of the VTAM MODEENT macro must be 2 or 3.
- The PSERVIC parameter of the VTAM MODEENT macro must specify LU Type=0.
- Byte 12 in the VTAM PSERVIC parameter must be modified so that it distinguishes a printer from a video. The following table shows the content that specifies each device type based on the bit location in byte 12:

*Table 11. Bits in Byte 12 of the VTAM PSERVIC Parameter*

Bits in Byte 12	Content
0-1	Device type: <ul style="list-style-type: none"> <li>00 Unspecified device type</li> <li>01 Printer device</li> <li>10 Display device</li> <li>11 Display/printer device (3275)</li> </ul>
2-7	Reserved.

If you specify nothing (B'00'), the default is B'10', which is a display device. <sup>11</sup>

**Related Reading:** For more information on defining non-SNA 3270 devices, see *ACF/VTAM System Programmer's Guide*.

**LU Type–2 Devices:** The following is a list of rules required for defining SLU–2 devices:

- The TSPROF parameter of the VTAM MODEENT macro must be 3.
- The PSERVIC parameter of the VTAM MODEENT macro must specify LU Type=2.

**Related Reading:** For more information on defining LU type–2 devices, see *ACF/VTAM System Programmer's Guide*.

**3275 Devices:** VTAM definitions alone cannot identify a 3275 device as it is logging on. Additional information (UNIT=3275) must be specified in a logon

11. B'00' means bits 0 and 1 equal 00. B'10' means bits 0 and 1 equal 10.

## Planning for ETO

descriptor. Define this descriptor in the CINIT user data or in the Logon exit routine. The descriptor itself must be identified as a 3275 device type.

Static 3275 devices are defined in the IMS system definition as follows:

```
TYPE          UNITYPE=3270
TERMINAL UNIT=3275,TYPE=3270-An,SIZE=(24x80),COMPT=PRT1
```

The 3275 has only one buffer. This forces the display and printer components to be the same model. The VTAM definitions for a dynamic 3275 as statically defined are:

```
PSERVIC=X'000000000000185000007EC0'
```

**NTO Devices:** The terminal must identify itself as an NTO device in one of the following ways:

- LU presentation services profile in the BIND image must specify LU1.
- When the LUTYPE is NTO, IMS uses the data stream compatibility byte to precisely define the specific NTO device type. If the LUTYPE specified is SLUTYPE1, the data stream compatibility byte is ignored. The terminal is assumed to be an actual SLUTYPE1 as defined on the logon descriptor.
- Logon exit routine, if available, must accept the DFSNTO (default) logon descriptor or specify an NTO logon descriptor that is defined by your installation using the node name or LOGOND user data parameter.
- The data stream compatibility byte in the CINIT specifies the device type:

```
2740          2740-1 NTO device
```

```
2741          2741 NTO device
```

```
WTTY          TTY NTO device
```

If none of these are specified, the device type is LUNS NTO.

### LU2 and Non-SNA 3270 Screen Size and Model Information

After the Logon exit routine approves the logon, BIND image data (screen-size) and feature information from the logon descriptor are used to search the MFS device characteristics table for the appropriate MFS device information. If the model is specified in the screen size control byte the MFS device characteristics table is not searched. A DFS3646 error message is issued if no match exists on screen-size and feature. The information from the proper MFS device characteristics table entry is then used for that device. This information in the MFS device characteristics table comes from the IMS system definition or the MFSDCT utility (DFSUTB00).

If the screen-size control byte is X'7F' and both the default and alternate screen-sizes are specified, a search of the MFS device characteristics table using alternate screen size commences. If no match is found, another search begins using the default screen size. If no screen size is found, message DFS3646I is issued to the operator.

The screen size (the product of the lines and columns) must be in the range 80-16384. The lines and columns must each be in the range 1-255.

If the screen size and features of the 3270 device that is logging on maps into two or more MFS device characteristics table entries, the first entry in the table that matches the screen size and features is selected.



If the screen-size control byte (the 11th byte of the PSERVIC on the VTAM MODEENT) is X'00' and both default and alternate screen-sizes are specified, a search of the MFS device characteristics table using the default screen-size occurs. If no match is found, another search begins using the alternate screen-size.

Use the Logon exit routine, DFSLGNX0, to override the screen-size or model for the device during logon.

**LU2 Screen-Size and Model Information:** Screen-size and model information applies to LU type-2 devices. The following is an algorithm IMS uses to determine the model or screen size for ETO terminals:

1. If you want to override the model value, use the Logon exit routine (DFSLGNX0). Valid values are X'01' and X'02', corresponding to model 1 and model 2 in the logon descriptor. Screen-size and model specifications in the VTAM PSERVIC are ignored. Model=X'01' represents a 12x40 screen-size. Model=X'02' represents a 24x80 screen-size. The MFS device characteristics table is not searched for MFS device information. The features are obtained from the logon descriptor.
2. If you want to override the screen-size value, use the Logon exit routine, DFSLGNX0. Be aware that if you override the model, the screen-size override is ignored. The features from the logon descriptor and the screen-size are used to search the MFS device characteristics table for the MFS device information.
3. Screen-size is established based on the model specification in the VTAM PSERVIC. IMS determines the model by checking the screen-size control byte in the VTAM PSERVIC field for an X'01', X'02', or X'03'. The model is established accordingly. Screen-size specifications are ignored when the model is specified. X'01' represents a model 1 with a 12x40 screen-size, and X'02' and X'03' represent a model 2 with a 24x80 screen-size. If the model is specified, the MFS device characteristics table is not searched for MFS device information. The features are obtained from the logon descriptor.
4. Screen-size is established based on the screen-size specifications in the VTAM PSERVIC. A value of X'7E' in the screen-size control byte causes the default screen size in the VTAM PSERVIC to be used. A X'7F' causes the alternate screen-size to be used first to search the MFS device characteristics table. If no match is found, the default screen-size is used to search; the first match is the screen-size. If no match is found, message DFS3646I is sent to the operator.
5. If the screen-size control byte is X'00', the default and alternate screen-size specifications in the VTAM PSERVIC are used to search the MFS device characteristics table for MFS device information. If a match is made on the default size, the default is used. If a match is made on the alternate size, the alternate is used. If no match is made, the logon is rejected.
6. If the screen-size control byte is X'00' and no screen-size is specified, the device is defaulted to a model 2 device, and the screen-size is established (24x80).
7. The screen-size is established in the BIND parameter in the default screen-size field. The erase write (EW) command is always used.

**Non-SNA 3270 Screen-Size and Model Information:** Model information applies to VTAM 3270 Record-Mode devices (non-SNA 3270s). To determine the model or screen-size for ETO terminals IMS uses the following algorithm:

1. If you want to override the model value, use the Logon exit routine (DFSLGNX0). Valid values are X'01' and X'02', corresponding to model 1 and model 2 in the logon descriptor. Screen-size and model specifications in the VTAM PSERVIC are ignored. Model=X'01' represents a 12x40 screen-size. Model=X'02' represents a 24x80 screen-size. If the model is specified, the MFS

device characteristics table is not searched for MFS device information. The features are obtained from the logon descriptor. Device type and screen-size are determined from the model value.

2. If you want to override the screen-size value, use the Logon exit routine (DFSLGNX0). Be aware that if you override the model, the screen-size override is ignored. The features from the logon descriptor and the screen-size are used to search the MFS device characteristics table for the MFS device information. Device type and screen-size are implied by the model value.
3. Screen-size is established based on the model specification in the VTAM PSERVIC field. IMS determines the model by checking the screen-size control byte in the VTAM PSERVIC field for X'01', X'02', or X'03'. The model is established accordingly. Screen-size specifications are ignored when the model is specified. X'01' represents a model 1 with a 12x40 screen-size, and X'02' and X'03' represent a model 2 with a 24x80 screen-size. If the model is specified, the MFS device characteristics table is not searched for MFS device information. The features are obtained from the logon descriptor. Device type and screen-size are determined from the model value.
4. Screen-size is established based on the screen-size specifications in the VTAM PSERVIC field. A value of X'7E' in the screen-size control byte causes the default screen size in the VTAM PSERVIC field to be used. A X'7F' causes the alternate screen-size to be used first in searching the MFS device characteristics table. If no match is found, the default screen-size is used to search; the first match is the screen-size. If no match is found, message DFS3646I is sent to the operator. Device type and screen-size are implied by the model value.
5. If the screen-size control byte is X'00', the default and alternate screen-size specifications in the VTAM PSERVIC field are used to search the MFS device characteristics table for MFS device information. If a match is made on the default size, the default is used. If a match is made on the alternate size, the alternate is used. If no match is found, the logon is rejected. Device type and screen-size are implied by the model value.
6. If no model information and screen-size are specified in the VTAM PSERVIC field, IMS uses the CINIT's model byte. Model type is established by the VTAM definition statement FEATUR2. The model information applies only if the screen-size control byte is X'00' and if the screen-size is also X'00'. This applies to printers and displays. X'00' is the default and corresponds to a model 1. X'01' corresponds to a model 2. Device type and screen-size are implied by the model value.
7. The screen-size is used to determine the type of write command used.
  - If the screen-size is equal to 960 or greater than 1920, IMS uses erase write alternate (EWA).
  - If the screen-size is less than or equal to 1920 and not equal to 960, IMS uses erase write (EW).

The device type and screen size are determined from the model value.

**Screen Definition Examples:** The following examples show the PESRVIC parameter in the VTAM mode table, what the equivalent TERMINAL macro parameters would be for a static terminal, and the corresponding MFS DEV statement TYPE parameter, which is used for both static and ETO terminals.

- LU0 (non-SNA 3270 video)
  - VTAM mode table: PSERVIC=X'000000000000000000000200'
  - TERMINAL macro: UNITYPE=3270 UNIT=3284/86 MODEL=2
  - MFS DEV statement: TYPE=(3270P,2)
- Model 2 non-SNA 3270 Printer

- VTAM mode table: PSERVIC=X'00000000000000000000240'
- TERMINAL macro: UNITYPE=3270 UNIT=3284/86 MODEL=2
- MFS DEV statement: TYPE=(3270P,2)

- Non-SNA 3270 Display (model specified)

- VTAM mode table: PSERVIC=X'00000000000000000000080'
- TERMINAL macro: UNITYPE=3270 MODEL=1
- MFS DEV statement: TYPE=(3270,1)

Model information can come from the FEATUR2 parameter for non-SNA 3270; if this parameter is not specified, this is a model 1 (screen-size 12x40). Assume that FEATUR2=1 (specified or default).

- Non-SNA 3270 Display (model specified)

- VTAM mode table: PSERVIC=X'00000000000000000000080'
- TERMINAL macro: UNITYPE=3270 MODEL=2
- MFS DEV statement: TYPE=(3270,2)

Model information can come from the FEATUR2 parameter for non-SNA 3270; if this parameter is not specified, this is a model 2 (screen-size 24x80). Assume that FEATUR2=2.

- Non-SNA 3270 Display (screen-size specified)

- VTAM mode table: PSERVIC=X'000000000000185000007E80'
- TERMINAL macro: UNITYPE=3270 TYPE=3270-A2,SIZE=(24,80)
- MFS DEV statement: TYPE=3270-A2, where A2=24x80

For a SLU-2 device, UNITYPE=SLUTYPE2 would be specified (also note the change to the PSERVIC field).

The screen-size comes from the default screen-size field (24x80). (For a SLU-2 device, the first byte of the PSERVIC field would be X'02'. The last byte would be X'00').

- Non-SNA 3270 Display (screen-size specified)

- VTAM mode table: PSERVIC=X'00000000000020500000080'
- TERMINAL macro: NITYPE=3270 TYPE=3270-A3,SIZE=(32,80)
- MFS DEV statement: TYPE=3270-A3, where A2=32x80

The screen-size comes from the default screen-size field (32x80). (For a SLU-2 device, the first byte of the PSERVIC field would be X'02'. The last byte would be X'00').

- Non-SNA 3270 Display (model specified)

- VTAM mode table: PSERVIC=X'00000000000000000000280'
- TERMINAL macro: UNITYPE=3270 MODEL=2
- MFS DEV statement: TYPE=(3270,2)

This is a model 2 non-SNA 3270 display (24x80).

- SNA 3270 Display (model specified)

- VTAM mode table: PSERVIC=X'02000000000000000000280'
- TERMINAL macro: UNITYPE=3270 MODEL=2
- MFS DEV statement: TYPE=(3270,2)

This is a model 2 SNA 3270 display (24x80).

## Planning a High-Security Environment with ETO

This topic describes your options for establishing security in an ETO environment.

## Planning for ETO

Implementing ETO enhances the security of your IMS. ETO adds security features that you can customize for your installation needs. For example, you can customize exit routines that apply to both static terminals and ETO dynamic terminals.

The ETO security features allow you to control each of the following:

- The physical connection of terminals to IMS.
- User signon to IMS.
- Output to users or nodes.
- Message queuing to users. You can customize message queuing two ways:
  - Automatically allocate an LTERM to a user that you identify at signon
  - Use the Output Creation exit routine (DFSINSX0)
- Command and transaction security, by using RACF (or an equivalent SAF-compliant security product).

### Static versus Dynamic Terminals

You define static terminals during system definition to associate an LTERM with a particular physical terminal. Any user at a terminal can receive output messages that are queued for that terminal, regardless of whether signon is required for that terminal.

The major benefit of ETO is that dynamic LTERMs (output message queues) are managed separately from the terminals and are assigned to a user name. The user can obtain output only after signing on. This dynamic LTERM-to-user association is maintained until the user signs off, and it remains after signoff if IMS does not delete the user structure.

### Using RACF versus SMU for Security

ETO terminals do not support the Security Maintenance utility (SMU). Only static terminals support SMU. If you are accustomed to using SMU for static-terminal security and want to continue using SMU for static terminals in a dynamic environment, two security profiles are necessary for your ETO environment:

**SMU** Using SMU, you design security profiles based on LTERM names.

**RACF** Using RACF, you design security profiles based on user IDs.

IMS Version 9 is the last version of IMS to support SMU. Through IMS Version 9, you can continue to use SMU to define signon and other security options for static terminals and for user structures that are defined during system definition.

**Recommendation:** Because IMS Version 9 is the last version of IMS to support SMU, it is recommended that you implement security using only RACF or an equivalent security product.

## Planning for MFS

After you implement ETO dynamic terminal support, the number and diversity of terminal types is likely to increase. When a terminal dynamically establishes an IMS session, MFS formats might not be available for the device type that is requesting the session. You can solve this problem by:

- Restricting device types to only those that are used in the MFS definitions for your application programs.

**Recommendation:** Use the Logon exit routine (DFSLGNX0) to select the desired logon descriptor.

- Extending the MFS device output formats to include the new terminal types that connect to the IMS.

### **Recommendations:**

- Use the MFS Generation utility (MFSGU) facilities, such as the STACK statement, to make creating these additional formats easier.
- Use the MFSDCT utility (DFSUTB00) to avoid needing to perform an IMS generation.

Often, multiple device types have similar or identical capabilities, so the distinction of device type might not be important to your environment. Although IMS application programs are usually not sensitive to device type, such a dependency can exist. For example, MFS can create different input messages from the same input data stream, due to differences in the format specification for device input.

## Planning User IDs

When planning user IDs for use with ETO:

- Ensure that dynamic user structures have unique names in IMS. Support for unique user IDs depends on whether user-based security is important. For user-based security, user IDs must be unique to the user. Otherwise, user IDs can be the same as the terminal LU name.
- Code the Signon exit routine (DFSSGNX0) to provide user ID suffixing, if users need to sign on to more than one terminal with the same user ID at the same time. Review and select the SGN and RCF EXEC keyword parameters.
- Analyze how application programs use the user field in the I/O PCB.

## Planning User Queue Names

When planning user queue names:

- Ensure that dynamic user queue names are unique in the IMS. Support for unique queue names depends on whether user-based security is important. For user-based security, user queue names must be unique to the user. Otherwise, user queue names can be the same as the terminal LU name.
- Specify user descriptors or provide logic in the Signon exit routine (DFSSGNX0) if the user queue name cannot be the same as the user name.
- Analyze how application programs use the LTERM field in the I/O PCB.

## Planning Operations

When planning for operations:

- Update your MTO procedures to reflect the concept of dynamic resources. The MTO needs to become familiar with the command input fields and response formats.
- Update the help-desk procedures to reflect the IMS terminal and user resource structures, as well as the commands that are required to diagnose user's problems.
- Review and update automated-operator procedures, if necessary.
- Develop procedures for handling the dead-letter queue.
- Identify requirements for autosignoff and autologoff.
- Develop standards for the conditions under which system-wide values should be used and when they should be overridden.

### Planning for MSC Support with ETO

Although MSC physical and logical links are predefined during system definition, you can dynamically create MSC remote LTERMs during IMS initialization. You can identify a remote MSC NAME to IMS using an MSC descriptor. The descriptor relates each remote resource to the link path name of a generated MSNAME macro.

**Recommendation:** Define remote LTERMs with MSC descriptors to maintain consistency between remote and local systems.

If you choose not to use MSC descriptors in order, the MSC Verification utility, DFSUMSV0, recognizes the remote LTERMs but not the corresponding local LTERMs in the target system. In this case, IMS issues warning message DFS2331W.

IMS processes MSC descriptors that are associated with MSC links defined within the IMS. IMS ignores other MSC descriptors. You can maintain a single network definition for remote LTERMs in IMS.PROCLIB for multiple interconnected IMSs that use MSC. In this case, each logical link path name must be unique throughout the entire network.

---

### Coding ETO Descriptors

IMS uses ETO descriptors to dynamically build terminal structures and user structures. The four types of ETO descriptors are:

- Logon
- User
- MFS device
- MSC

The basic format for all ETO descriptors is:

Column	Description
1	One of the following descriptor types: <ul style="list-style-type: none"><li><b>L</b> Logon descriptor</li><li><b>U</b> User descriptor</li><li><b>D</b> MFS device descriptor</li><li><b>M</b> MSC descriptor</li><li><b>*</b> Comment line (ignored by IMS)</li></ul>
3-10	Name of the descriptor, using the following conventions: <ul style="list-style-type: none"><li>• Must be one to eight alphanumeric characters.</li><li>• For logon and user descriptors, characters are limited to A-Z, #, \$, and @.</li><li>• For MSC descriptors, use the link name.</li></ul>
12-72	One or more keywords and their parameters, separated by blanks. Use commas to separate multiple parameters for a single keyword.
73-80	Optional sequence numbers (ignored by IMS).

**Related Reading:** For more information on defining ETO descriptors and ETO descriptor formats, see *IMS Version 9: Installation Volume 2: System Definition and Tailoring*.

## Creating Descriptors Using the System Definition Process

To ease migration, you can create a starter set of ETO descriptors (except MFS<sup>12</sup> descriptors) using the ETOFEAT keyword on the IMSCTRL macro at system definition. You can add to or modify the starter set by creating an additional IMS.PROCLIB member.

**Restriction:** An LGEN system definition does not create ETO descriptors.

**Related Reading:** For more information on using the ETOFEAT keyword and creating the IMS.PROCLIB member with the ETO descriptors, see *IMS Version 9: Installation Volume 2: System Definition and Tailoring*.

Creating descriptors during the system definition process saves you time and ensures that the descriptors are correct. IMS generates an ETO descriptor report, which provides information on the relationship between ETO descriptors and the IMS system definition resources that they represent.

## Storing Descriptors

Descriptors that are created during system definition are stored in the IMS.PROCLIB member, DFSDSCMx. Subsequent system definitions of the same stage-1 input deck overwrite the DFSDSCMx member.

**Recommendation:** To avoid losing descriptors when member DFSDSCMx is replaced, store descriptors that you create by using TSO or z/OS utilities in IMS.PROCLIB member, DFSDSCTy. If you need to update descriptors that are created at system definition in DFSDSCMx, use TSO or a z/OS utility (such as IEBUPDTE) to make the updates.

## Creating Logon Descriptors

Logon descriptors provide IMS with information about the physical characteristics of the terminals that establish logon sessions. These characteristics must be consistent with the VTAM logon BIND characteristics.

This topic describes how to create and use logon descriptors.

### Logon Descriptor Format

The format for a logon descriptor is as follows:

---

12. The system definition creates a device characteristics table based on the stage-1 input that can be used as one of the inputs to the MFSDCT utility (DFSUTB00). The device characteristics table contains what the system-defined device characteristics table contains, plus any additional entries from device descriptors.

## Coding ETO Descriptors

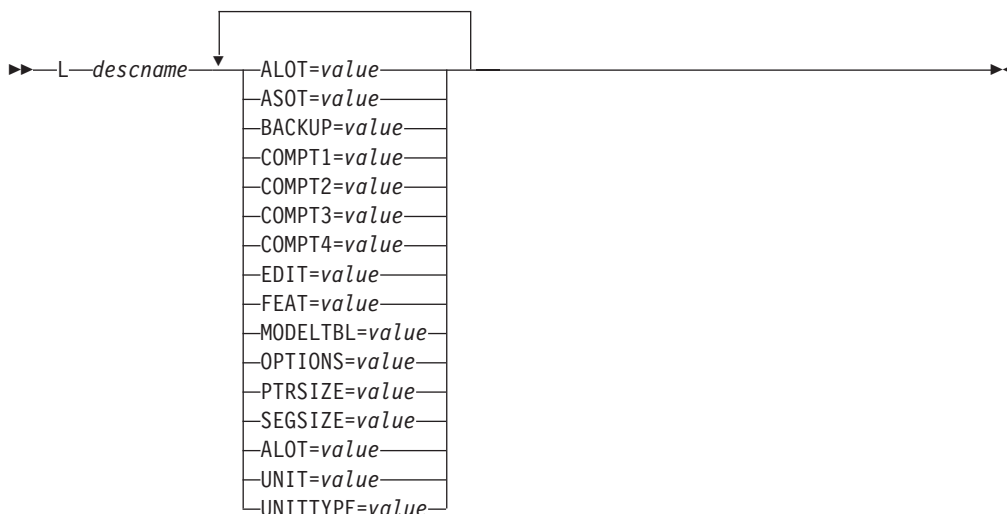

**L** Indicates that the descriptor type is logon.

### *descname*

The name of the descriptor, which can be an IMS default descriptor name, the field name of the TERMINAL macro, or a unique name you create.

Default names include: DFS3270, DFS327P, DFSFIN, DFSSLU1, DFSSLU2, DFSSLUP, DFSLU61, DFSNTO.

### **KEYWORD=**

For a complete description of all the keywords that the ETO logon descriptor supports, see *IMS Version 9: Installation Volume 2: System Definition and Tailoring*.

Because you do not need to define the maximum number of ETO-ISC sessions, the SESSION keyword is not supported on the ETO descriptor. You can continue to add sessions while storage and CPC capacity exist. The UNIT keyword is valid for non-SNA 3270 terminals only.

**Example:** An example of a logon descriptor is:

```
Column   Column
 1        12
L MKT01LU2 UNITYPE=SLUTYPE2 ALOT=30
```

You can use multiple records to create a single descriptor name (for example, if the number of parameters causes the descriptor to exceed one 80-byte record).

**Example:** The following is an example of a logon descriptor with multiple records:

```
L MKT01LU2 UNITYPE=SLUTYPE2
L MKT01LU2 ALOT=30
```

## Creating Logon Descriptors at System Definition

When you specify IMS system definition options to create ETO logon descriptors, IMS dynamically creates a logon descriptor for every unique VTAM TERMINAL macro<sup>13</sup> that you have specified. IMS system definition can produce up to 37 common logon descriptors for each device type. The descriptor that defines the largest number of terminals of that type becomes the default logon descriptor. This

13. For each TERMINAL macro definition, a node user descriptor is also created for use as a migration step to ETO.



logon descriptor assumes the IMS-defined default name for that type. The other terminals of that type create their own unique logon descriptor by using a suffix on the default name.

For terminal definitions that don't match one of the 37 common descriptors, IMS creates an individual logon descriptor. These descriptors are generated as comments (with an asterisk in column 1). To choose a descriptor that you need, remove the asterisk.

**Example:** \*L3270A

The naming convention for the 37 common logon descriptors that are created during the system definition process is:

- The last character of the name must be unique.
- Blank for the most common, then 0-9 and A-Z.

### **Restrictions:**

- During system definition, IMS does not create ETO logon descriptors for the primary or secondary master terminal, or for LU 6.1 terminals that are defined as XRF ISC links.
- During large system definition (LGEN), IMS does not generate logon descriptors.
- The following keywords are not supported on logon descriptors: PU, SIZE, MODEL, TYPE, MSGDEL.

### **Criteria for Selecting Logon Descriptors**

The logon descriptor contains data that is related to the node and the VTAM CINIT. This data allows IMS to create a control block structure that supports a session.

IMS uses the following criteria (in sequence) to select a logon descriptor:

1. IMS uses existing control blocks for terminals. IMS does not look for a descriptor if it finds existing control blocks.
2. IMS determines whether the Logon exit routine is used to define logon descriptor names. The exit routine extracts the name from the VTAM CINIT<sup>14</sup> user data, or another appropriate algorithm. IMS rejects invalid logon descriptor names.
3. In response to a request to establish a session (logon), IMS examines the LOGOND parameter.<sup>15</sup> The LOGOND parameter can indicate the logon descriptor for IMS to use.

**Restriction:** LOGOND is not valid for ISC parallel sessions.

4. If IMS does not find a logon descriptor name, it looks for a logon descriptor with the same name as the VTAM CINIT LUNAME.

**Recommendation:** Use the node name on the logon descriptor if you expect any of the following situations:

- You don't expect to add more of the same terminal type.
- You don't have many of the terminal type.
- You want to simplify the logic in the Logon exit routine.

---

14. The LUTYPE and TS= (transmission service level) fields in the VTAM CINIT data must agree with the selected descriptor; otherwise, the logon is rejected.

15. LOGOND is a parameter in the VTAM CINIT user data. LOGOND is also a keyword on the IMS /OPNDST command.

## Coding ETO Descriptors

- For ISC, you want to specify parameters (such as OUTBUF=) other than the default ISC logon descriptor, and you have not coded an exit routine.

If these criteria do not yield a valid logon descriptor name, IMS selects a descriptor by using the default criteria.

### Criteria for Selecting a Default Logon Descriptor

IMS provides a default logon descriptor for each VTAM terminal type. The logon descriptor name is based on the LU type and TS profile. If necessary, you can add logon descriptors. If you do not provide a logon descriptor, and IMS does not locate one in IMS.PROCLIB or in the Logon exit routine (DFSLGNX0), IMS uses the algorithm shown in Table 12 to assign a default logon descriptor name. The VTAM LUTYPE, IMS UNITYPE, and IMS default logon descriptor names are shown for each terminal type.

Table 12. Mapping for VTAM LUTYPE, IMS UNITYPE, and Default Logon Descriptor Names

VTAM LUTYPE	IMS UNITYPE	Default Descriptor Name
X'06'	LUTYPE6	DFSLU61
X'02'	SLUTYPE2	DFSSLU2
X'01'	SLUTYPE1 (Default) <sup>1</sup> NTO	DFSSLU1 DFSNT0
X'00' (TS = X'04')	SLUTYPEP (Default) <sup>2</sup> Finance 3601	DFSSLUP DFSFIN DFSFIN
X'00' (TS = X'02' or X'03')	3270 3270, UNIT=3284	DFS3270 DFS327P

#### Notes:

1. IMS does not distinguish between SLUTYPE1 and NTO terminals; SLUTYPE1 is the default. To support both SLUTYPE1 and NTO terminals, do the following:
  - Override the DFSSLU1 default logon descriptor by using the Logon exit routine (DFSLGNX0) or by specifying the LOGOND parameter.
  - If your installation has no SLUTYPE1 terminals, rename the DFSNTO logon descriptor to DFSSLU1 in order to make it the default for LU type X'01' terminals.
2. IMS does not distinguish between SLU type-P, Finance, and 3601 terminals; SLUTYPEP is the default. ETO considers Finance and 3600 series terminals to be the same. To support both SLUTYPEP and 3600/Finance terminals, do the following:
  - Override the DFSSLUP default logon descriptor by using the Logon exit routine (DFSLGNX0) or by specifying the LOGOND parameter.
  - If your installation has no SLUTYPEP terminals, rename the DFSFIN logon descriptor to DFSSLUP in order to make it the default for LU type X'00' (TS = X'04') terminals.

The default logon descriptor is determined in one of three ways:

- IMS looks for the most common logon descriptor created during IMS system definition and uses it as the default.
- If no terminal definition exists for that terminal type, IMS creates a default logon descriptor.
- Your installation can create a default logon descriptor.

### Using NTO, 3600/Finance Terminals

Because of conflicting CINIT information, IMS cannot generate DFSNTO or DFSFIN as a default logon descriptor name. CINIT parameters for SLU 1 are identical to NTO, and SLU P is identical to 3600/Finance.

**Recommendations:** For 3600/Finance and NTO terminal types, take each of the following actions:

- Always supply the appropriate logon descriptor name in the Logon exit routine (DFSLGNX0). You can generate this name as a constant, based on LU name, LU type, or CINIT user data.
- Ensure that the logon descriptor name is provided as the LOGOND parameter from the BIND user data.
- Ensure existence of a logon descriptor that matches the node name of the terminal that is logging on. If IMS does not find a default logon descriptor, the logon attempt fails.

### Recovering ETO Terminals Using XRF

To recover ETO terminals in an XRF environment, use the BACKUP= parameter when specifying the logon descriptor. The BACKUP= parameter sets the priority that controls the order in which sessions are switched.

When 3600/Finance and SLU-P terminals are defined as class-2 terminals in an XRF environment, automatic re-logon and re-signon occur during a takeover.

**Related Reading:** For general information on XRF, see *IMS Version 9: Administration Guide: System*.

## Creating User Descriptors

User descriptors provide information relating to user options and user structure names. IMS needs user descriptors in order to create control blocks that enable users to use ETO terminals.

The three types of user descriptors are:

- Installation-created
- Node user
- DFSUSER

IMS chooses the first valid descriptor, using the given sequence. IMS creates DFSUSER and node user descriptors using system definition options.

This topic describes how to create user descriptors.

### User Descriptor Format

The format for all three types of user descriptors is:

U username KEYWORD=parm1 KEYWORD=parm2...KEYWORD=parmN

**U** Indicates the descriptor type is user.

#### username

The name of the descriptor, which can be a unique user ID you create, a node user name assigned to a TERMINAL or SUBPOOL macro, or the IMS default descriptor name, DFSUSER.

#### KEYWORD

One of the following keywords:

- ASOT=
- AUTLDESC=
- AUTLGN=
- AUTLID=

## Coding ETO Descriptors

- AUTLMOD=
- LTERM=
- OPTIONS=
- RCVYCONV=
- RCVYFP=
- SRMDEF=

**parm** A parameter value for the keyword

**Related Reading:** For more information on valid parameter values, see *IMS Version 9: Installation Volume 2: System Definition and Tailoring*.

**Example:** An example of a user descriptor specification is:

```
Column      Column
1           12
U SMITH     ASOT=20 LTERM=(SECLT1) AUTLGN=SEC01LU2
```

### Creating User Descriptors at System Definition

User descriptors are generated from each VTAM TERMINAL or VTAMPOOL SUBPOOL macro. User descriptors that are created during system definition by using the VTAM TERMINAL macro have the same name as the terminal. User descriptors that are created by using the VTAMPOOL SUBPOOL macro have the same name as the subpool.

For user descriptors that are created by using a SUBPOOL macro, you cannot set a response option (TRANSRESP, NORESP, FORCRESP), because it is defined on the TERMINAL macro for static definitions. You need to add the response option (appropriate for your installation) to any user descriptor that is created with a SUBPOOL macro.

### Criteria for Selecting User Descriptors

When a user signs on, if the user structure does not exist, IMS selects a user descriptor to build the user structure. IMS selects the user descriptor according to the following criteria:

1. An installation-written exit routine can select the name of the user descriptor (user ID, node name, or DFSUSER).
2. IMS looks for USERD, provided at logon. IMS also looks for a descriptor name (user ID, node name, or DFSUSER) that is specified in the USER descriptor field of the /SIGN or /OPNDST command.
3. IMS looks for a descriptor that has the same name as the user ID (installation-created user descriptor only). If IMS finds one, and an LTERM keyword is not specified in the descriptor, IMS creates a user structure and a single LTERM, both of which have the same name as the user ID.
4. IMS looks for a descriptor that has the same name as the VTAM node (node user descriptor). If IMS finds one, and an LTERM keyword is not specified in the descriptor, IMS creates a user structure and a single LTERM, both of which have the same name as the VTAM node. However, no output security is associated with this user structure. Any user that signs on at a terminal can receive messages that are queued for that terminal.
5. IMS selects the default user descriptor, DFSUSER. IMS creates a user structure and a single LTERM, both of which have the same name as the user ID.

### Using Installation-Created User Descriptors

You can create your own installation-specific user descriptors that meet important criteria for your site. The name of the installation-created user descriptor is the

same as the user ID. You can add values to these user descriptors that are not provided with node user descriptors or DFSUSER descriptors.

### Using Node User Descriptors

Node user descriptors help in migrating from static terminal definitions to ETO dynamic terminal definitions. During IMS system definition, node user descriptors are created as an option. Node user descriptors can be useful when exit routines that perform descriptor selection are not yet complete.

Node user descriptors must have the same name as their associated terminals. Therefore, IMS creates unique node user descriptors that retain user options and user structure names that exist in the system definition. When IMS system definition creates ETO descriptors, a node user descriptor is created for each terminal that has a VTAM TERMINAL macro or VTAMPOOL SUBPOOL macro. Node user descriptors are created even when they match the DFSUSER options.<sup>16</sup>

If the LTERM parameter of the node user descriptor contains the same name as a statically defined LTERM, the node user descriptor is ignored. IMS issues message DFS3673W. Consequently, all node user descriptors that are created during system definition are generated as comment statements. To use the node user descriptors, remove the asterisks.

In most cases, node user descriptors are not needed. You only require node user descriptors when the default user descriptor (DFSUSER) or the Signon exit routine (DFSSGNX0) cannot supply the user options you desire. Using a TSO or a z/OS utility, you can discard most of the node user descriptors that are created during system definition.

Be aware that when you use node user descriptors, you cannot use ETO's ability to eliminate the need for predefining terminals that connect to IMS. Using node user descriptors lose output security for each user as well.

### Recommendations:

- If continuous availability of IMS is critical, eliminate node user descriptors as soon as possible. Because adding new terminals by using node user descriptors requires an IMS restart, use exit routines instead of node user descriptors.
- To avoid using node user descriptors, use the Signon exit routine (DFSSGNX0) to have IMS build a user structure using the node name as the user name. Although this is similar to using node user descriptors, it avoids predefining large numbers of these descriptors at IMS initialization.
- You can use node user descriptors to start a session when output is available, using /OPNDST, LOGON, or autologon. To use autologon, specify the SHARE option on the TERMINAL macro.
- If you select a default user descriptor using the Signon exit routine (DFSSGNX0), you can set a bit to indicate that IMS should create the user structure using the node name for the user structure name. This is the same as selecting a node user descriptor. By creating node-name structures by using the Signon exit routine, rather than by defining a node user descriptor for each terminal, large network installations benefit from decreased complexity.

### Using DFSUSER User Descriptors

If IMS does not find a user descriptor that has the same name as the user ID or the terminal that is signing on, and no exit routine has provided one, IMS uses

---

16. No descriptor is created for an ISC terminal that is defined for parallel session support.

## Coding ETO Descriptors

DFSUSER as the default descriptor. IMS uses DFSUSER for both signon and application program output processing. Using DFSUSER also enables IMS to dynamically create a user structure for a signon request when no other user descriptor is available.

IMS creates DFSUSER when you specify the system definition options to create ETO descriptors. DFSUSER contains the options specified most frequently in your IMS system definition, and it should satisfy most users. However, using the DFSUSER descriptor does not require you to use all of these options. You can code the Signon exit routine (DFSSGNX0) to make changes to the structures that are built by using DFSUSER.

DFSUSER builds a user structure that has the same name as the user ID that is specified on the /SIGN command. IMS allocates to this user structure a single LTERM, which also has the same name as the user ID. You can use the Signon exit routine (DFSSGNX0) in order to supply multiple queues, if necessary.

**Recommendation:** Fully implementing ETO involves creating most user resources using DFSUSER. After migrating to ETO, use the DFSUSER descriptor for as many users as possible. Minimizing the number of descriptors reduces the administrative workload of an IMS network.

The user structure name becomes the user ID. When you use the DFSUSER descriptor, you can modify user structure names and other options by using the Signon exit routine (DFSSGNX0).

**Related Reading:** For more information on using the Signon exit routine (DFSSGNX0), see *IMS Version 9: Customization Guide*.

If an application program has a dependency on an LTERM name that exists in an I/O PCB, you can customize ETO in one of two ways:

- Provide a user descriptor for each user that is to use a particular application program.
- Use the Signon exit routine (DFSSGNX0) to tailor the default action for a subset of the user population.

The Signon exit routine (DFSSGNX0) and the Output Creation exit routine (DFSINSX0) enable you to dynamically create user structures, even when the specified user descriptors do not contain data to create LTERMs.

**Related Reading:** For more information on the Signon exit routine (DFSSGNX0) and the Output Creation exit routine (DFSINSX0), see *IMS Version 9: Customization Guide*.

## Creating MFS Device Descriptors

With MFS device descriptors, you can define screen size and feature combinations that are not generated during IMS system definition. The MFSDCT utility (DFSUTB00) uses the MFS device descriptors in order to update device type, screen size, and features in the MFS device characteristics table. MFSDCT also uses MFS device descriptors to generate new MFS default formats, without requiring changes to the system definition. The MFS device descriptors are not created as part of a system definition, but are instead an optional step after IMS system definition.

MFS device descriptors define terminal characteristics of dynamic terminals that differ from static terminals. Unless you use exit routines to override screen sizes,

you need to ensure that all ETO terminal screen sizes that are different from those that are defined for static terminals are defined using MFS device descriptors.

**Recommendation:** If you have users who log on to terminals that have different device characteristics, you need to create an expanded set of MFS formats. Input and output messages that are delivered to non-originating terminals are formatted to the terminal according to the MFS formatting specifications that are defined for that device.

### MFS Device Descriptor Format

The format for an MFS device descriptor is:

```
D descname KEYWORD=parm1 KEYWORD=parm2 KEYWORD=parm3
```

**D** Indicates that the descriptor type is MFS (device).

#### descname

The name of the descriptor.

#### KEYWORD=

One of the following keywords: FEAT=, SIZE=, TYPE=.

**parm** A parameter value for the keyword.

**Related Reading:** For more information on valid parameter values, see *IMS Version 9: Installation Volume 2: System Definition and Tailoring*.

**Example:** An example of an MFS descriptor is:

```
Column      Column
1           12
D IMSTYP22  TYPE=3270-A04 SIZE=(43,80) FEAT=IGNORE
```

**Related Reading:** For more information on the values for the FEAT, SIZE, and TYPE keywords on the TERMINAL macro, see *IMS Version 9: Installation Volume 2: System Definition and Tailoring*.

### Building the Device Characteristics Table

When someone logs onto an ETO 3270 or SLU-2 terminal that is connected to IMS, usually the screen size is provided to IMS in the VTAM CINIT PSERVIC data. Sometimes the model number is also provided. IMS uses this screen size and the features that are specified on the logon descriptor in order to search the MFS device characteristics table, which contains one or more entries. Each entry identifies the following:

- The MFS device type
- The screen size
- The features

Searching the table, you can find the MFS device type. If the search is unsuccessful, the logon attempt is rejected, and messages DFS3646 and DFS3672 are issued.

The MFS device characteristics table is built in one of two ways:

- The IMS system definition process builds an MFS device characteristics table based on the TYPE=, SIZE=, and FEATURE= specifications of the TERMINAL macro. Each unique combination has an entry in the MFS device characteristics table.
- The MFS DCT utility (DFSUTB00) builds or modifies an MFS device characteristics table based on the input of the MFS device descriptor. These

## Coding ETO Descriptors

descriptors have the TYPE=, SIZE=, and FEATURE= specifications that the TERMINAL macro has. When the VTAM CINIT PSERVIC indicates a model number instead of a screen size, the MFS device characteristics table is not searched. A model number indicates a certain screen size and MFS device type.

The MFS device characteristics table is not searched if the VTAM CINIT PSERVIC field contains a model number instead of a screen size.

**Related Reading:** For more information on using the MFSDCT utility (DFSUTB00), see *IMS Version 9: Utilities Reference: Database and Transaction Manager*.

### Using the MFSDCT Utility (DFSUTB00)

During session initiation, IMS searches the device characteristics table in order to locate MFS device information, in either of the following situations:

- The screen size is overridden.
- The model value in PSERVIC is X'00', X'7E', or X'7F'.

The MFSDCT utility (DFSUTB00) enables you to define screen sizes that are not defined during IMS system definition. The MFSDCT utility uses MFS device descriptors in PROCLIB member DFSDSCMx and DFSDSCTy, without performing an IMS system definition. The new screen size definitions are added to those that are already defined.

The MFSDCT utility procedure is found in IMS.PROCLIB. You must evaluate the screen size requirements and code MFS device descriptors to meet those requirements. The MFSDCT utility must generate all possible combinations of screen sizes and features that your installation might require.

To use the MFSDCT utility, follow these steps:

1. Execute DFSUTB00 (the MFSDCT utility). The MFS utility does the following:
  - Reads device descriptors from IMS.PROCLIB members DFSDSCMx and DFSDSCTy.
  - Builds one device descriptor table entry statement for each new device descriptor.
  - Terminates if no descriptors are specified.
  - Optionally loads the existing device characteristics table from IMS.SDFSRESL, and builds one entry statement for each existing table entry.
  - Passes the table entry statements and the DCTBLD and MFSINIT macros as input to assembler.
  - Prepares assembler output as a new or updated device characteristics table, as well as a new set of default MFS format definitions. Output is in separate files for subsequent processing.
2. Assemble the new device characteristics table.
3. Link edit the new device characteristics table into IMS.SDFSRESL.
4. Execute phase 1 of the MFS Language utility in order to generate new default MFS format control blocks.
5. Execute phase 2 of the MFS Language utility; the new default MFS formats are loaded into IMS.FORMAT.

You can specify any of the following parameters in the PARM field of DFSUTB00:

#### **DCTSUF=x**

Specifies the suffix character that is to be appended to member DFSUDT0x.



This suffix indicates which device characteristics table is to be used for input that is merged with the device descriptions.

If this suffix is not specified, IMS builds a new device characteristics table.

### **DSCTSUF=x**

Indicates which member DFSDSCTx is to be used for input. This parameter is required if DSCMSUF is not specified.

### **DSCMSUF=x**

Indicates which member DFSDSCMx is to be used for input. This parameter is required if DSCTSUF is not specified.

### **DEVCHAR=x**

Specifies the suffix character that is to be appended to the name DFSUDT0x. This name becomes the new name for the new or updated table. The default is 0 (zero). Any existing table with the same name is replaced.

Problems with the device characteristics table are often indicated (by error messages DFS3646 and DFS3672) during logon processing.

## Creating MSC Descriptors

MSC descriptors relate remote LTERMs to statically defined MSC links. IMS creates MSC descriptors when you specify IMS system definition options to create ETO terminal descriptors. MSC descriptors relate remote NAME macros to defined MSC links.

**Recommendation:** Define all LTERMs in remote IMS systems by using MSC descriptors. The MSC Verification utility in the target IMS system can then associate the remote LTERMs with the corresponding local LTERMs. IMS issues message DFS2331W if the corresponding local LTERMs are not found.

IMS only processes those MSC descriptors that are associated with the MSC links that are defined within the system being initialized. IMS ignores all other MSC descriptors. If each logical link path name is unique in the network, you can maintain your network's MSC definition source in a single PROCLIB member, IMS.PROCLIB.

### **MSC Descriptor Format**

The format for an MSC descriptor is:

```
M linkname name1 name2...nameN
```

**M** Indicates the descriptor type is MSC (device).

#### **linkname**

The name of the link path from an MSNAME statement.

**name** Any valid remote LTERM name that is accessed through the linkname.

**Example:** An example of an MSC descriptor is:

```
Column      Column
1           12
M REMSYS01 REM01AAA REM01BBB REM01CCC REM01DDD REM01EEE REM01FFF
M REMSYS02 REM01GGG REM01HHH REM01III
```

### Exit Routines

You can use the following exit routines to customize ETO:

- Initialization exit routine (DFSINTX0)
- Logon exit routine (DFSLGNX0)
- Logoff exit routine (DFSLGFX0)
- Signon exit routine (DFSSGNX0)
- Signoff exit routine (DFSSGFX0)
- Output Creation exit routine (DFSINSX0)
- Greetings Message exit routine (DFSGMSG0)

If ETO is enabled, these exit routines are loaded during IMS initialization. All non-MSA and non-LU 6.2 VTAM terminals (static or dynamic) can use these exit routines.

You can code these ETO exit routines with a wide range of processing logic for any of the following purposes:

- Enforcing naming conventions
- Selecting user queues
- Overriding terminal characteristics, such as screen size
- Enhancing security by limiting access to IMS terminals
- Overriding security by allowing signon without using a security product, such as RACF
- Selecting operational parameters, such as timeout values

**Related Reading:** For more information on coding these exit routines, see *IMS Version 9: Customization Guide*.

---

### Starting ETO

To include ETO in your IMS system, specify ETO=Y in the IMS or DCC startup procedure.

The default for the ETO= keyword in the startup procedures is ETO=N. If ETO=N remains specified, IMS rejects requests to establish sessions for undefined terminals. Messages that are destined for nonexistent queues are refused, and IMS issues message DFS064 or an A1 status code.

When IMS initializes, it calls the Initialization exit routine (DFSINTX0). You can code this exit routine to disable ETO, or to create and load data that you want ETO to use. IMS maintains a pointer to this data and passes this pointer to the ETO exit routines as an input parameter. IMS passes this pointer to non-ETO exit routines through the SCDINTXP field in the system contents directory (SCD).

When you enable ETO, IMS validates each ETO descriptor:

- If a descriptor is coded incorrectly, IMS ignores it and issues message DFS3640W to the MTO.
- If IMS detects an invalid parameter within a valid descriptor, IMS substitutes the default parameter, and processing continues with message DFS3641W.
- If IMS is unable to read all the descriptors (for example, because of read errors), IMS abends with abend U0015. IMS does not abend if it finds one valid logon descriptor and one valid user descriptor.

- IMS does not start a system whose descriptor information is incomplete.

**Related Reading:** For information on messages and error codes that might be issued at initialization time, see *IMS Version 9: Messages and Codes, Volume 1* and *IMS Version 9: Failure Analysis Structure Tables (FAST) for Dump Analysis*.

Descriptors, exit routines, and the MFS device characteristics table can be added, deleted, or updated before IMS initialization time. However, if a control block for a session exists across restart, a change in the descriptor that built the control block does not take effect until after the control block is deleted. For example, 3600/Finance, SLU-P, and ISC sessions can warm start with control blocks created from an original descriptor, even when that descriptor is changed or deleted after the control blocks were created.

---

## Logging onto ETO Terminals

You can log on to your terminal in three ways. You can use:

- The IMS /OPNDST command, and optionally include signon data.
- The SNA commands INITSELF, INITOTHER, or USS LOGON, and optionally include user data for signon.
- ETO autologon, which includes user data based on user descriptors or exit routines. The user data is then passed to signon.

If you specify ETO=Y, you can establish sessions with ETO terminals, but only if each of the following is true:

- An available logon descriptor provides sufficient information to create the control blocks necessary to accept the session request.
- In addition to the required logon descriptor, a 3270 or SLU-2 terminal requires an entry in the MFS device characteristics table that matches its screen-size and features. However, IMS does not search the MFS device characteristics table if the 3270 or SLU-2 terminal is identified as model 1 or 2.
- If the screen-size control byte is X'7F' in the PSERVIC field of the VTAM MODEENT macro, IMS searches the MFS device characteristics table using the alternate screen-size. If no match is found, IMS searches the MFS device characteristics table using the default screen-size. If you specify both sizes, and you want to use the default screen-size, the Logon exit routine (DFSLGNX0) must specify the default screen-size as an override.
- If the user cannot specify the logon descriptor in the user data, you must use the Logon exit routine (DFSLGNX0) or let IMS choose the default logon descriptor based on the terminal type.

## Limiting Dynamic Logon To Specific Terminal Types

If you want to limit dynamic logon to specific terminal types, delete the default logon descriptor for those terminal types you do not want to logon dynamically. You can also reject the default logon for specific terminal types by using the Logon exit routine (DFSLGNX0). Dynamic logon for these terminal types fails.

**Related Reading:** For information on selecting default logon descriptors, see "Criteria for Selecting a Default Logon Descriptor" on page 164.

## Creating and Reusing LTERM Control Blocks

A user structure containing an LTERM is created:

- When the user signs on, and the user structure does not currently exist

## Logging onto Your ETO Terminal

- When an asynchronous message is created for an LTERM, and the LTERM does not currently exist
- When you use the /ASSIGN command to assign an LTERM to a non-existent user.
- The /ASSIGN command is used to assign a non-existent LTERM to a user.
- The /CHANGE USER user AUTOLOGON command is directed to a non-existent user.

The user structure is allocated to a terminal after successful signon.

## Using Default CINIT or BIND User Data Formats

Each request for session initiation can include VTAM CINIT or BIND user data to provide logon descriptor or signon data. Your installation can provide a logon exit routine to process this data.

IMS can receive optional user data when you establish a session using one of the following methods:<sup>17</sup>

- Using an IMS /OPNDST command
- Using autologon
- The RTO provides a user logon

You can expand the user data formats to meet your own requirements. You can either supply the logon descriptor name in your logon exit routine by using user data, or you can create the logon descriptor name by using an IMS algorithm.

The user data appears in the CINIT user data field, and it is available to IMS when the VTAM Logon exit routine is scheduled. One optional parameter, the logon descriptor name, applies to the IMS logon process. The remaining parameters apply to the IMS signon process and, optionally, to RACF. During either process, IMS does minimum processing on the CINIT user data parameters before first calling the optional installation Logon exit routine (DFSLGNX0), and later calling the Signon exit routine (DFSSGNX0).

Although the Logon and Signon exit routines can translate any installation-defined user data format, IMS has defined a default user data format that:

- The installation can expand.
- IMS can process in the absence of exit routines. This format is the logon descriptor name followed by signon data in the same format as the IMS /SIGN command.

**Restriction:** For warm session initiation of an STSN device, the user data must be the same as in the original logon.

### **Related Reading:**

- See *IMS Version 9: Customization Guide* for more information on:
  - The Logon and Signon exit routines
  - The format of the CINIT user data
  - Restrictions that apply to ISC
- See *IMS Version 9: Command Reference* for more information on the /SIGN command.

---

<sup>17</sup> ETO ISC terminals do not have optional data available. ISC supports an SNA format defined in the *IMS Version 9: Customization Guide*.

- For information on the default user data format, see Appendix D, “Format for CINIT User Data Parameters,” on page 521.

---

### Signing On and Queue LTERM Allocation

**Definition:** *Signing on* to an ETO terminal identifies a user to IMS, creates a user structure, and connects this user structure to the terminal structure.

Users at VTAM terminals can sign on by:

- Issuing the /SIGN command.
- Signing on at the DFS3649 message screen.
- Providing user data with the session initiation request.

Users that establish a dynamic VTAM session with IMS must enter valid signon data before LTERMs are allocated to the session. You can require that the signon data be validated by a security product, such as RACF.

### Providing Signon Data

Users can enter signon data by using one of the following methods:

- Using the /SIGN command
- Including the signon data with the logon user data
- Coding the Logon exit routine (DFSLGNX0)

### Providing Signon Data for ISC, SLU-P, Finance, and Output-Only Devices

For dynamic ISC, SLU-P, Finance, and output-only devices, you must provide user signon data at session initiation. IMS validates the signon data and allocates LTERMs to the terminals, based on:

- User descriptors in IMS.PROCLIB
- Applicable LTERM and user option defaults
- Signon exit routine (DFSSGNX0) output

**Restriction:** A user cannot enter signon data from an output-only device during logon or when using the /SIGN command. For a dynamic output-only terminal, users must enter signon data at session initiation.

If a user forgets to include signon data during session initiation for an output-only device, IMS issues message DFS2085 (with return code 264) to the MTO. If signon data is omitted for dynamic ISC, SLU-P, or Finance terminals, IMS issues messages DFS3645 and DFS3672.

### Signing On Multiple Times

Users can concurrently sign on to one or more terminals. These terminals can be a combination of both static and dynamic terminals. For both static and dynamic VTAM terminals, you must specify the EXEC parameter, SGN=M (multiple signons enabled).

For dynamic terminals, the name of the user structure that represents the user to IMS must be unique. You can use one of four methods to make the user structure unique:

## Signing On and LTERM Allocation

- Use the Signon exit routine (DFSSGNX0) to return a 1- to 3-byte suffix to the user ID. The total length of the user ID plus the suffix cannot exceed eight characters.

**Recommendation:** Use a naming convention that ensures unique user IDs. For example, you can create suffixed user IDs using the Signon exit routine (DFSSGNX0), and check the uniqueness of these user IDs by using IMS Callable Services.

**Recommendation:** If you are operating in a sysplex environment, create a naming convention that ensures unique user IDs across the IMSplex by creating a suffix from the following:

- As the first part of the suffix, the Signon exit routine can attach the unique part of the IMS system identifier, which is specified on the IMSID parameter, to the user ID.
- As the second part of the suffix, use IMS Callable Services to choose an available value for the user on that IMS system.

**Example:** A user with a user ID of USER signs on to IMSA. A unique suffix of A1 is created through this two-step process:

1. The Signon exit routine appends the A from IMSA to the user ID.
2. The Signon exit routine invokes IMS Callable Services. The exit routine then appends a 1, representing the first user named USER to sign on to IMSA.

In this example, user IDs must be less than six characters in length.

- Use the Signon exit routine to specify that the user structure name is the same as the node name.
- Use the Signon exit routine to specify a name that is unrelated to the user ID or the node name.
- Specify a user descriptor name that is the same as the node name, causing the name of the user structure to be the same as the node name. You can do this by using one of the following methods:
  - Enter signon data that contains the user descriptor name.
  - Use the Signon exit routine to specify the node user descriptor.
  - Specify no user descriptor and let IMS use the node user descriptor by default.

Unless you specify SGN=M to enable multiple signons, the user ID for a dynamic user must be unique. If the user ID is used as the user-structure name, it must be unique, regardless of whether you specify SGN=M. If the user ID is not used as the user-structure name (for example, by using the Signon exit routine), you must specify SGN=M for multiple signons.

**Recommendation:** Assigning a single name to an IMS user is useful in determining output status. If you use multiple names for individual users (for example, when the Signon exit routine assigns them), you must provide a means to determine the user names that are created by signons.

**Restriction:** You cannot use the same name for a dynamic LTERM and a static LTERM that is defined during system definition.

**Related Reading:** For information on the Signon exit routine (DFSSGNX0) and IMS Callable Services, see *IMS Version 9: Customization Guide*.

## Receiving the Signon Required Message—DFS3649A

The ETO user must sign on before a session can enter transactions or commands. The user can enter the /RCLSDST command only before signing on. IMS issues message DFS3649A (indicating that a /SIGN command is required) in each of the following situations:

- After a signon failure
- After a signoff
- After a logon in which no user data is entered

Any terminal user can then issue a /SIGN ON command to begin the next session.

You do not receive the DFS3649A message in any of the following situations:

- Signon data is included in the VTAM CINIT or BIND.
- The session is an ISC, SLU-P, Finance, or 3270 printer session.
- The terminal is a SLU-1 terminal running in unattended mode.
- The terminal is the subject of an autologon attempt.

### **Related Reading:**

- For more information on receiving message DFS3649A, see *IMS Version 9: Messages and Codes, Volume 2*.
- For more information on the /SIGN ON command, see *IMS Version 9: Command Reference*.

## Receiving the Session Status Message—DFS3650

After a user successfully signs on (or if signon is not required), IMS issues message DFS3650, indicating the status of the session with IMS.

**Exceptions:** In the following situations, IMS does not send message DFS3650:

- When SLU-1 terminals run in unattended mode.
- When you specify the NOTERM option on the user descriptor.

Message DFS3650 provides information on session status, such as:

- Whether the user is in conversation mode
- Whether user output security exists for the terminal

**Related Reading:** For more information about when message DFS3650 is issued, see *IMS Version 9: Messages and Codes, Volume 2*.

## ETO Terminal-LTERM Relationship

The system programmer is responsible for the relationship between a terminal that is in session with IMS and a particular user's LTERMs:

- For a single-component terminal (such as a SLU 2), IMS creates a single default LTERM name that is the same as the user ID that was supplied during signon. Using an exit routine or a user descriptor, you can give the LTERM a different name.
- For a multi-component terminal (such as a SLU P), you need to ensure that sufficient LTERMs are created in order to use that terminal. You can use exit

## Signing On and LTERM Allocation

routines, installation-created descriptors, or node user descriptors <sup>18</sup>to ensure that a sufficient number of LTERMs is created. Otherwise, IMS creates a single LTERM that is allocated to the first component of the terminal.

It is possible for an application program to associate a specific LTERM name with a specific terminal. The system programmer must ensure that names of alternate PCBs are consistent with LTERM names defined in:

- User descriptors
- Signon exit routine
- Insert exit routine
- Recovery requirements for ISC, SLU-P, and Finance sessions

## How IMS Determines Which Queues to Allocate

IMS uses the following method to determine which LTERMs to allocate:

1. If the user control blocks already exist within IMS, these control blocks are reallocated, and the Signon exit routine is called, if appropriate.
2. If the control blocks do not exist and a user descriptor is specified at signon, IMS looks for the specified descriptor.
  - If the descriptor specified is not the user ID, node name, or DFSUSER descriptor, IMS sends error message DFS3649A (with return code 148).
  - If the descriptor specified is a valid user descriptor for the user that is signing on, IMS builds a table of available descriptors and calls the Signon exit routine, if appropriate.
  - If the Signon exit routine exists and RC=0, IMS continues normal signon processing. If the return code does not equal 0, the signon is rejected.
3. If no user descriptor is specified at signon and no user descriptor is specified in the Signon exit routine, IMS chooses a valid descriptor from the following (in order):
  - a. User ID
  - b. Node name
  - c. DFSUSER

**Related Reading:** For more information on the Signon exit routine (DFSSGNX0), see *IMS Version 9: Customization Guide*.

## Setting Special Processing Modes

After user signon, you can set the following processing modes by using IMS commands:

<b>Exclusive mode</b>	/EXCLUSIVE command
<b>Preset destination mode</b>	/SET command
<b>MFS test mode</b>	/TEST MFS command
<b>Test mode</b>	/TEST command

These special processing modes, except for the test mode and the preset destination mode, are retained for the user after signing off and are reestablished with the next terminal on which the user signs on.

---

18. The user needs to use the node user descriptor to establish the correct relationship between the LTERM and the node, either explicitly or in the Signon exit routine (DFSSGNX0).



When you issue the following commands, IMS creates the required control blocks for a terminal or user, or it maintains a user's status:

<b>/EXC USER</b>	Places a user structure in exclusive mode.
<b>/STOP NODE or /STOP USER</b>	Stops a node or user structure.
<b>/TEST MFS USER</b>	Places a user structure in MFSTEST mode. When a user signs on, IMS places the terminal in MFSTEST mode, if the terminal supports MFS.
<b>/TRACE NODE</b>	Traces a logged-on node.

To reset terminal status and make the control blocks eligible<sup>19</sup> for deletion at the next simple checkpoint, use the following commands:

<b>/END</b>	Clears exclusive and test modes.
<b>/RESET</b>	Removes the preset destination.
<b>/RSTART</b>	Starts stopped resources.
<b>/START<sup>20</sup></b>	Starts stopped resources.
<b>/TRACE</b>	Sets trace off.

Use the preceding set of commands if the control blocks exist solely for status retention.

You can use the Signoff exit routine, DFSSGFX0, to reset these states.

**Related Reading:** For more information on deleting control blocks, see "Improving Performance by Deleting ETO Control Blocks" on page 189.

---

## Printers with ETO

Two methods of implementing printer support exist in an ETO environment:

- Direct printing
- Associated printing

How you implement these two methods depends on how your application programs identify printer LTERM names.

### Direct Printing

**Definition:** *Direct printing* is a printing technique by which application programs insert messages to the VTAM LU name. The dynamic LTERM and the user and terminal resources are all named after the VTAM LU name. Many application programs can queue data to the same printer LTERM, but this can create data interleaving problems.

### Associated Printing

**Definition:** *Associated printing* is a technique for directing application program printer output to a specific printer node name.

---

19. Control blocks are not immediately deleted when special status is removed. They are deleted at the next checkpoint if they meet all deletion requirements. If an outstanding status exists, they are not eligible for deletion.

20. See the *IMS Version 9: Command Reference* for other status reset by the /START command.

### How Associated Printing Works

For associated printing, application programs insert messages to the queue that is associated with the screen-user queue name. User printing requests cause application programs to queue data to different printer LTERMs. This avoids data interleaving problems.

Printer signoff and signon are required to change the user queue. Overhead can be high if the printer has many users.

Associated printers are logged on automatically when their LTERMs have queued messages, usually during an IMS restart or during the creation of an LTERM.

**Recommendation:** Carefully plan how your printers are to be shared among application programs.

By implementing exit routines and application programs, the terminal operator can provide the destination during logon or signon.

### Identifying Printer Node Names

You can identify printer node names in one of two ways:

- As logon user data, you can include one or more printer node names when a user establishes a session.
- Your installation can modify the MFS format for the DFS3649A greeting message in order to allow the user to supply the printer node names at signon time. During the signon, however, the Signon exit routine must be able to detect the printer node names as user data.

### Coding the Signon Exit Routine for Associated Printing

To use associated printing, code the Signon exit routine (DFSSGNX0). Code the Signon exit routine to do each of the following steps:

- Identify the printer LU name and user name for each screen user.
- Determine printer node names from the input user data.
- Name user-related LTERM structures to service the selected printers.
- Enable application programs to determine (using the user ID) the queues associated with a particular user so that the programs can insert to the correct message queue (alternate PCB).
- Pass the printer node names to IMS as associated print parameters.
- Determine the user name that is allocated to each printer when users supply printer node names. You can use either an algorithm or a table to make this determination. The exit routine should pass these user names to IMS, which then creates the necessary user control blocks.

A unique name should exist for the user ID that is signed on and for each printer-related user that is required.

**Example:** To indicate the name of a user's printer identification, add a "P" to the end of the user ID. If the user ID is AAA, the name of this user's printer identification is AAAP.

- Specify one value for each of up to four printers (the number of simple checkpoints before the user structure is deleted).

**Related Reading:** For more information on the Signon exit routine (DFSSGNX0), see *IMS Version 9: Customization Guide*.

The application program can use the same method as the Signon exit routine in order to determine the printer LTERM name from the input terminal user ID and queue output data as required through an alternate PCB. When output data is queued, IMS allocates the user structure to the correct printer and delivers the output.

After associated printer LTERMs are allocated and then emptied, the queues are deallocated from the terminal.

## Defining Your Printers

Printers are usually output-only devices; however, they can be implemented so that they send input.

You need to decide whether to have single-user or multiple-user structures share the same printer. If your application programs are sensitive to queue names, you might be limited to one or the other approach.

### Single-User Structure

Using a single-user structure that represents a printer is the simplest method for defining a printer. In this case, messages sent to the printer are printed in the sequence in which they originate. Interleaving of output can occur. Multi-segment messages always have all segments printed in contiguous sequence. Multiple messages might behave differently, depending on their method of origination.

### Multiple-User Structures

Multiple users are supported for printers. All messages for a single user are printed, and the next user is selected for printing only when the current user has no more output. Although interleaving of messages for the same user occurs as it does for single-user structures, the switching of users can also be equivalent to message interleaving from an application standpoint. Application and operational awareness of the way printers are shared is important.

The challenges of sharing printers are not unique to dynamic terminals, and in fact are the same as for static terminals.

IMS prints a separator page whenever the next message to be printed is from a different user. You can control the contents of this separator page by using an exit routine to change its content; however, this page is always printed, even if blank. Messages from the same user are not separated by a separator page. Using the NOTERM option can prevent the DFS3650 separator message from being used.

## Sharing Printers Using ETO

Several users can use the same output terminal:

- Users can define a single-user descriptor that contains all the LTERM names that are used to deliver data to an output device (node).
- Users can define autologon parameters for a node.

Before deciding which of these methods to use, ask these questions:

- Are the LU-to-LTERM relationships generally unchanging?
- Is interleaving at the message level acceptable?
- Is delaying one user's output acceptable while another user's output is being printed?

## Printers with ETO

- Is continuous autosignoff and autologon processing overhead too excessive for a particular terminal because of the minimal message delivery rate of each LU user?

The answers to these questions can help to determine your method of implementation:

- If the answer to all of the questions is “yes”, consider creating a single multi-LTERM user for the printer.
- If any of the answers is “no”, consider dynamic allocation of multiple-user LTERMs, using autologon.
- You can implement a combination of these two options.

---

## Operator Commands

This topic describes using the /OPNDST and /ASSIGN commands as they are used with ETO.

### /OPNDST

The VTAM mode table that is used when the terminal first logs on determines the device characteristics. However, if the first reference to a terminal is through an /OPNDST command, the MODETABLE operand of that command determines the device type.

Omitting the MODETABLE operand on the command causes it to default, which might not be desirable. After the terminal is in session with IMS, the rules for block deletion apply. The device type remains set until the block is deleted; if the terminal is closed and then reopened, IMS uses the existing block, if available. If a block is deleted, that block is rebuilt during the next terminal logon. As a result, the /OPNDST command can have different results, depending on two things:

- Whether the block is still available (and has not been deleted).
- Whether the exit routine or descriptor has been changed since the previous initialization.

### /ASSIGN

You can use the /ASSIGN command to move queues from one terminal to another. You cannot use it to reassign a static terminal to a dynamic (ETO) terminal, or to assign a dynamic terminal to a static terminal.

**Related Reading:** For information on reassigning user IDs, see the /ASSIGN USER command in *IMS Version 9: Command Reference*.

---

## System Definition Parameters for ETO

This topic describes the system definition parameters you can use with ETO.

### Setting DEADQ Status Time with the DLQT Parameter

User control block structures are normally created as a result of any of the following situations:

- When a terminal is logged on and a user signs on.
- When the AO exit routine (DFSABE00) inserts a message to an LTERM or transaction.
- When an asynchronous transaction output message is sent, or a terminal message switch or /BROADCAST LTERM command is issued.

Messages might be sent to destinations that are unknown, no longer valid, or nonexistent. IMS sets a status of dead-letter queue (DEADQ) when an ETO user control block structure or its associated message queues have not been accessed within the time limit that is set by the DLQT execution parameter (1-365 days).<sup>21</sup> The DEADQ status can be set regardless of whether messages have been queued for the user or whether the user is still allocated to a terminal. The DEADQ status is set during IMS checkpoints, and the MTO is notified with message DFS3643.

If the user has messages queued, remove the DEADQ status by signing on the user or by issuing the /DEQUEUE or /ASSIGN command.

User control block structures without queued messages can result in a DEADQ status. User control blocks are not deleted if a special status is pending. The status might have been set during the prior signon (such as response or conversation mode) or as a result of a command (such as /STOP or /EXCLUSIVE). If the control block remains unused for longer than the time specified for the DLQT execution parameter, IMS assigns the control block a DEADQ status, and the MTO is notified with message DFS3643.

If the user control block has DEADQ status, the status is removed when the user signs on or during the next checkpoint after all messages are dequeued and recoverable status conditions are removed using appropriate commands. In the latter case, the control blocks for the user and associated message queues are also deleted.

User control block structures that have DEADQ status might or might not be allocated to a terminal. In the case of LU type-6, SLU-P, and Finance terminals, the user structure can be allocated to the terminal with no active session. Logoff or other session termination can leave these terminals pending message recovery (SNA STSN). The user remains allocated to the terminal, and messages might or might not be queued.<sup>22</sup>

If the user control block structure is allocated to an LU type-6, SLU-P, or Finance terminal, remove the DEADQ status by logging on and signing on the user, or by using the /DEQUEUE command. For LU type-6 (ISC) terminals use the /DEQUEUE command, or force the LU type-6 session to cold start. A forced-session cold start is a /STO NODE, /ASSIGN (USER TO VTAMPOOL), /STA NODE sequence that is valid only for LU 6. Forced cold start is not possible for SLU-P or Finance terminals. Clearing the allocation of an ETO user to a SLU-P or Finance terminal requires an IMS cold start.

In a shared-queues environment, you can use the /DISPLAY QCNT MSGAGE command to find the age of a queue.

### Autosignoff (ASOT)

*Autosignoff* involves deallocating users from an idle session. Users are automatically signed off if no activity occurs within an allotted time. The system programmer sets this time using the ASOT (auto signoff time) parameter in the DFSPByyy member. If users are automatically signed off, they must sign on again in order to use the session.

---

21. A value of 1 is not usually recommended. It can result in many premature and misleading DEADQ status settings during the first checkpoint.

22. This combination is not possible for other VTAM terminal types, because a deallocation of the terminal and user ID is forced at logoff and signoff.

## System Definition Parameters for ETO

If more than one allotted time value exists, IMS uses the following criteria to determine which allotted time value to use:<sup>23</sup>

- If the valid ASOT value is specified in the user descriptor, this allotted time value is used.
- If the user descriptor does not specify an allotted time value, the allotted time value from the logon descriptor is used.
- If the logon descriptor does not specify an allotted time value, the time value from the DFSPByyy member is used.
- If the DFSPByyy member does not specify an allotted time value, the default value of 1440 is used.
- If the value on the DFSPByyy member is not valid, the default value of 10 is used.

The Logon exit routine (DFSLGNX0) can override the ASOT and ALOT values during logon. The Signon exit routine (DFSSGNX0) can override the ASOT value during signon, even when the control block structure exists.

The values for the allotted time specified on the ASOT parameter in the DFSPByyy member are:

- ASOT = 0
  - The user is signed-off immediately when no output is available to be sent. This specification is normally used with Autologon terminals for signoff immediately when:
    - No IMS input or output message is available
    - After the last available output message completes
  - This specification is not recommended for interactive terminals such as 3270's or SLU2. These terminals sessions normally return a PA key to continue following signon. Idle time results in immediate signoff, not waiting for terminal input.

The value on the DFSPByyy member is not used for these device types.

- ASOT = (10 - 1439)
  - The user is signed off after the allotted number of minutes has elapsed without terminal activity.
- ASOT = 1440
  - The user is never automatically signed off. This is equivalent to not having autosignoff. The system default value for SLU-P, 3600/Finance, and ISC terminals is 1440.

After autosignoff completes, IMS attempts to locate a user that has the same node name that is waiting for autologon. If IMS finds another user with output waiting, the user is allocated to the terminal, and the queues are drained.

## Autologoff (ALOT)

*Autologoff* involves terminating a session with IMS for a terminal that has been signed off for an allotted period. After an allotted time, the terminal is automatically logged off. The system programmer sets this time on any of the following:

- On the ALOT (auto logoff time) parameter in the DFSPByyy member

---

23. The time value on the ASOT EXEC parameter does not apply to 3600, SLU P, or ISC devices.

- On the logon descriptor that is used to create the session control blocks
- On the EXEC parameter at initialization

If more than one allotted time value exists, the following criteria are used to determine which allotted time value to use:

- If the ALOT value is specified on the logon descriptor, this allotted time value is used.
- If the logon descriptor does not specify a valid allotted time value, the time value specified in the DFSPByyy member is used.
- If the DFSPByyy member does not specify an allotted time value, the default value of 1440 is used.
- If the value on the DFSPByyy member is not valid, the default value of 10 is used.

You can specify ALOT=1440 on the logon descriptor for a 3600/Finance, SLU-P, or ISC terminal in order to specify that no autologoff is desired. The system default value for these devices is 1440. Logon descriptors created for ISC terminals should have ALOT=1440 specified to show that autologoff should not occur. The Logon exit routine (DFSLGNX0) can override the ALOT value during logon, even when the control block structure exists.

The values for the allotted time specified on the ALOT parameter in the DFSPByyy member are:

### **ALOT = 0**

The terminal is logged-off immediately when no signon is in effect. This specification is normally used in terminal sessions when the user is signed-on automatically during the logon process. During autologon, signon data can be provided in one of the following ways:

- Signon data supplied by the IMS /OPNDST command
- Signon data supplied by logon user data (BIND)
- Signon data supplied by logon exit (DFSLGNX0)

There are two modes of operation for using ALOT=0, either of which can be set using the DFSINTX0 User Initialization Exit parameter list.

In default mode, when signon errors are encountered, the session is automatically signed off and then logged off; no message is sent. If you do not supply the DFSINTX0 exit, or you supply the exit and indicate default mode for ALOT=0, then signon data must be supplied during the logon process. All of the following error conditions result in automatic logoff:

1. A non-signon, or errors detected during signon or input processing, result in immediate logoff.
2. /SIGNOFF results in immediate logoff.
3. /SIGNON signs off the current user and signs on a new user. However, errors encountered during the signon process, such as detection of an incorrect or expired password, result in immediate logoff.

**Restriction:** Default mode should not be used for interactive terminal sessions that require a response to the DFS3649 message; these sessions will not wait for input signon and will logoff immediately.

## System Definition Parameters for ETO

In alternate mode, when signon errors are encountered, the session is automatically signed off, a message is sent and the session is logged off. Signon data can be supplied but is not required. All of the following error conditions result in automatic logoff:

1. A non-signon error detected during input processing results in immediate logoff.
2. No signon data has been provided by the logon serrated (BIND) or the Logon Exit (DFSLGNX0).
3. A /SIGNOFF, or errors resulting from a /SIGNON, cause message DFS3649(A) (Signon Required) to be sent, and a fixed ten-minute timer set to wait for a new signon. If no signon occurs during that interval, then the session is logged off.

### **ALOT = (10 - 1439)**

The session is terminated after the allotted number of minutes has elapsed without a signed-on user.

### **ALOT = 1440**

The session is never automatically terminated. This is equivalent to not having autologoff.

## Autosignoff and Autologoff Timer

The VTAM I/O Timeout Facility (if active) detects users or sessions that should be automatically terminated. A timer pops at intervals of one minute if the VTAM I/O Timeout Facility is active, or five minutes if the Timeout Facility is not active. The timer starts a routine that determines which resources are due for autosignoff or autologoff. The specified timeout value is the minimum value for which a user or session is automatically terminated. Termination actually occurs the next time the timer pops after the specified timeout value.

## Autologon

Instead of using the SHARE option on the TERMINAL macro to request that IMS automatically initiate a terminal session when output is available, ETO offers autologon support for ETO terminals and users. You specify autologon parameters when defining the user to IMS.

**Definition:** *Autologon* allows IMS to log on and sign on your terminal automatically. If you specify the autologon option for a user, the queueing of data to any of the user queues causes IMS to establish a session. You can specify autologon using:

- AUTLGN= parameter on the user descriptor
- Output Creation exit routine (DFSINSX0)
- Signon exit routine (DFSSGNX0) for associated printers
- /CHANGE command with the AUTOLOGON keyword

Autologon includes both automatic logon and automatic signon. At restart, IMS attempts to start sessions with those terminals that are defined with autologon and that have queued data waiting. After the session is established, IMS automatically signs on the terminal. If a queue of waiting users exists and the allocated queues are drained, the autologon user is signed off, regardless of an existing ASOT value.

IMS manages a serial queue of waiting users if more than one user is contending for the same autologon terminal. After the autologon user is signed off, the next



autologon user for the same terminal is automatically signed on. When all autologon users have signed off, the terminal is free to begin its ALOT cycle in order to terminate the session.

Autologon replaces the TERMINAL macro OPTIONS=SHARE for static terminals. OPTIONS=NOASR (no automatic session restart) on the logon descriptor is ignored for autologon printers. IMS always assumes OPTIONS=ASR for autologon printers.

Autologon is normally specified for output-only terminals. Autologon and occasional users generally do not share the same terminal session, but sharing terminal sessions is possible for interactive terminals. Interactive users on terminals that are subject to autologon must supply user signon data with the session initiation request (logon) in order to avoid contention with autologon output. Occasional terminal users can use autologon in order to have output delivered to default terminals when the output becomes available after signoff. If a terminal is stopped, the /START NODE command does not start a session. The /OPNDST NODE USER command can be used to restart the session.

---

### Assigning Output

These topics discuss assigning output and include the following subtopics:

- “Asynchronous Output”
- “Delivering Output Messages to Non-Originating Terminals” on page 188
- “Inadvertent Output Data Streams” on page 189

### Asynchronous Output

ETO provides IMS the flexibility to create user structures for any authorized user that is signed on. IMS automatically creates user structures for message switches and for the application insert call (ISRT) process when the LTERM cannot be found.

With ETO, all destinations are valid unless they are rejected by exit routines. Therefore, you can mistakenly create queues for users if you make typographical errors when entering any of the following:

- Alternate PCBs
- Message switches
- /BROADCAST commands
- MSC output

**Definition:** The LTERMs used in the previous situations are known as *dead-letter queues*. IMS provides commands for the MTO to monitor these queues and dispose of them.

**Related Reading:** For more information on dead-letter queues, see “Asynchronous Output to an Invalid Destination” on page 188.

The two types of asynchronous output destinations are valid and invalid.

**Definitions:** A *valid destination* is one intended to receive output. An *invalid destination* is one that is not intended to receive output (for example, a misspelled destination).

## Assigning Output

### Asynchronous Output to a Valid Destination

You can send asynchronous output (such as inserts, broadcasts, and message switches) after you have specified the following:

- ETO=Y
- A descriptor that is valid for creating a user structure
- A valid destination LTERM name

If control blocks exist for a previously created user structure and LTERM, the control blocks are reused.

### Asynchronous Output to an Invalid Destination

IMS refers to data that cannot be delivered as “dead letter”. Data cannot be delivered in each of the following situations:

- No autologon destination is available for queued output.
- The user ID to which the data is associated is not a valid user ID.
- The user signon is always rejected by an installation Signon exit routine.
- An invalid destination is specified on the input or output message (for example, resulting from a typing error).

You can specify a DLQT value on the EXEC parameter at initialization in order to automatically notify the MTO when LTERM queues exceed this value and have not dequeued data or removed the status. You can use each of the following commands against dead-letter queues:

- Use the /DISPLAY USER DEADQ or /DISPLAY STATUS USER command to identify users whose LTERM queues are older than the dead-letter-queue time (DLQT), and who have not dequeued data or removed the status.
- Use the /ASSIGN command to reassign dead-letter queues to other dynamic users so they can review queued data.
- Use the /DEQUEUE command to purge data on the dead-letter queues.

In a shared-queues environment, you can use the /DISPLAY QCNT MSGAGE command to determine the messages that are considered to be dead-letter queues.

**Related Reading:** For more information on these commands, see *IMS Version 9: Command Reference*.

## Delivering Output Messages to Non-Originating Terminals

IMS sends your output to the terminal on which you are signed on. Using ETO, you can receive your output messages at a different terminal than the one from which you entered the input. However, the input and output messages are formatted subject to the MFS specifications defined for both the terminal and messages, as follows:

- MFS formatting is mandatory for 3270R (non-SNA) and SLU-2 terminals, except when you use MFS bypass. MFS formatting is optional for all other VTAM terminals. Use MFS on a message-by-message basis, based on MID and MOD control block availability. MFS paging support is not available for SLU-1 or NTO terminals.
- You must define MID and MOD control blocks by using device statements that generate appropriate DIF and DOF control blocks. This allows you to map the message to and from a specific terminal type at the time that the message is sent

to or received from the terminal. Default mapping occurs when the appropriate MFS blocks are not available. IMS issues error message DFS057 when the format blocks cannot be found.

If you plan to deliver output messages to non-originating terminals, you must develop or expand MFS formats, procedures, and restrictions. This allows users to move freely between terminals.

## Inadvertent Output Data Streams

Using ETO, dynamic terminal users can move freely between terminals; limited only by installation constraints. It is possible to erroneously send terminal-specific data to the wrong terminal type by mistyping the IMS /ASSIGN command. When this happens, the data, when delivered, has errors or is not recognizable. Be sure to create MFS definitions for all terminal types for which users can log on.

---

## Signing Off

**Definition:** *Signing off* of an ETO terminal ends the identification of a user to IMS, and (in most cases) disconnects the user structure from the terminal structure and deletes the user structure.

When a user signs off from an ETO VTAM terminal, IMS calls the Signoff exit routine (DFSSGFX0).

**Recommendation:** If you have provided a Signon exit routine (DFSSGNX0) that maintains system information, provide a Signoff exit routine (DFSSGFX0) also, to complement that processing.

---

## Logging Off

When a user logs off from a VTAM terminal when ETO is used, IMS calls the Logoff exit routine (DFSLGFX0).

**Recommendation:** If you have provided a Logon exit routine (DFSLGNX0) that maintains system information, provide a Logoff exit routine (DFSLGFX0) also, to complement that processing. Ensure that the Logoff exit routine handles all non-MSU and non-LU 6.2 terminals with which IMS communicates.

Using the Logoff exit routine, you might want to maintain a count of the terminals that are logged on.

---

## Improving Performance by Deleting ETO Control Blocks

With ETO, IMS can dynamically delete control blocks. Dynamically deleting control blocks reduces storage usage and can improve performance.

If special terminal processing options (TRACE and STOPPED) are reset, IMS deletes session control blocks if one of the following occurs:

- No user is signed on, and a checkpoint occurs.
- The session is terminated normally or abnormally by either an MTO command or by an autologoff timeout.

If the node is a 3600/Finance or SLU P terminal, message resynchronization is necessary. The control blocks are not deleted following warm-session termination, but will be deleted following a /CHANGE NODE COLDSESS command. For ISC

## Logging Off

terminals, the control blocks are deleted after a cold-session termination. The control blocks remain, however, after an ISC warm-session termination.

If the user resets special processing options, such as those that exist after issuing a /SET, /TEST MFS, or /EXCLUSIVE command, and issues the /SIGN OFF command (or is automatically signed off), IMS deletes the user control blocks if:

- No messages are queued to any LTERMs related to this user.
- The user is not in conversation or Fast Path mode.

If the preceding conditions exist, dynamically created user control blocks are deleted. If the preceding conditions do not exist, the user control blocks can continue to exist until the conditions exist or until an IMS cold start occurs. After special processing options are reset and if all other criteria for deletion exist, the control blocks are deleted at the next checkpoint.

**Important:** User control blocks can be saved across session and IMS restarts by using the /CHANGE or the /ASSIGN commands with the SAVE keyword. These user control blocks are then retained until the commands are reentered with the NOSAVE keyword.

**Note:** In an IMSplex, if the status recovery mode is GLOBAL or NONE, the local control blocks are deleted immediately after logoff or signoff.

---

## IDC0 Trace Facility

You can use the IDC0 Trace facility to diagnose logon and logoff errors. This facility provides information that the IMS message DFS3672 cannot provide. To use the facility, enter: /TRACE SET ON TABLE IDC0. The facility traces the following events:

- Errors that occur in the IMS VTAM exit routines (within module DFSCNXA0). These errors are also identified in a DFS3672 message, regardless of whether the IDC0 Trace is in effect.
- Errors that occur when attempting to log onto a nonexistent VTAM node (such as entering a /OPNDST command for a nonexistent terminal). IMS issues associated messages DFS2061 or DFS2062.
- Synchronization anomalies that occur between the time that an IMS VTAM exit routine completes processing and the time that the request is accepted by normal IMS processing. The result is a X'6701' log record identified with a VTPO string.

**Related Reading:** For more information on the IDC0 Trace facility and the format of the X'6701' log record identified with a VTPO string, see *IMS Version 9: Diagnosis Guide and Reference*.

---

## ETO and LU 6.1 (ISC) Terminals

For LU 6.1 (ISC) terminals, IMS supports parallel sessions to the same node name. In this case, a separate structure is built for each session. However, each session and its associated structure operate independently, as a separate terminal.

ISC supports an SNA-defined user-data area within the BIND. When establishing a session for ISC, each half-session partner is identified through an appropriate session qualifier that is included as user data with the logon. These two qualifiers cannot be specified using the DFSLGNX0 exit routine. One belongs to each half session. IMS uses the session qualifier of the current half session as a user

structure. This user structure is used to allocate an associated set of LTERM queues and to automatically provide a RACF signon, if required. The other half-session qualifier is saved with the IMS user structure. Both qualifiers are used for session-restart requests and SNA STSN message resynchronization after session failures.

**Restriction:** The SNA-predefined format for user data does not support some of the parameters and options of the non-ISC end-user format:

- The RACF password and group name are not supported. IMS supports RACF signon for ISC with PASSCHK=NO during user structure allocation as part of session initiation.
- The LOGOND and USERD are not supported. IMS uses defaults, unless specified on the Logon and Signon exit routines.
- When autologon is generated for ISC terminals, the AUTLDESC keyword in the user descriptor is ignored, and the LOGOND keyword in the user data is omitted.

**Related Reading:** For information on BIND user data formats, see *IMS Version 9: Customization Guide* and “Using Default CINIT or BIND User Data Formats” on page 174.

---

## ETO and STSN Terminals

The following topics provide information on administering ETO for STSN terminals:

- “SNA STSN Terminal Considerations”
- “ETO and 3600/Finance and SLU P” on page 192
- “/SIGN Support for ETO STSN Devices: ISC, Finance, and SLU P” on page 192

## SNA STSN Terminal Considerations

ETO terminals that use the SNA STSN function (Finance, SLU-P, and ISC) must provide a user queue name during logon, because this queue is used to resolve the sequence number exchange that is part of the IMS connection process for this type of terminal. The ways to provide the user name include:

- CINIT data sent by the terminal
- CINIT data provided using a separate terminal host product, such as VTAM unsolicited system services
- A user Logon exit routine (DFSLGNX0), except for ISC
- An IMS command (/OPNDST can specify user name)
- Autologon parameters supplied by user descriptors or by the Output Creation exit routine

The Logon exit routine is the last opportunity to provide the user name. If no user name is provided for ETO STSN terminals, the logon is rejected with an error message. This differs slightly from other terminal types, which allow user signon after the logon has occurred. A signon is required before being able to use the terminal for IMS activity (transactions or commands), so the difference is only in requiring the signon data earlier for STSN terminals. The /SIGN command is supported for STSN terminals.

### ETO and 3600/Finance and SLU P

You can sign on to static system-defined 3600/Finance and SLU P terminals in one of two ways: using the /SIGN command or using logon user data. You can change the signon identification by using another IMS /SIGN command at any time. LTERMs are assigned to the terminal during system definition and are not affected by the signon process or by the SNA STSN message recovery process. The signon simply provides user access and input authorization.

IMS supports 3600/Finance and SLU-P terminals as dynamic terminals. They can use autologon or signon data with the logon request in order to dynamically allocate user structures. Signon data must be provided at session initiation for ETO 3600/Finance and SLU-P terminals. Signon data can be supplied in the Logon exit routine (DFSLGNX0) at the cold start of a session. The LTERMs and user IDs allocated at the cold start session are retained across sessions and IMS outages because of the VTAM STSN message resynchronization requirements. This requires that the same user signon data be used for subsequent warm-start sessions to both reverify the user and to allow message resynchronization.

When dynamic XRF Finance and SLU-P terminals are defined as XRF class-2, automatic re-signon and logon occur at takeover time.

### /SIGN Support for ETO STSN Devices: ISC, Finance, and SLU P

For ETO STSN devices, user data is required at the time that the session is allocated to create the user structure. After the user structures are created and allocated to the terminal, /SIGN commands are accepted from ETO STSN terminals.

When you issue the /SIGN command from an ETO STSN terminal, IMS initiates a complete signon process to create the security profile associated with the session for the new user.

When the user signs off, the user's security profile is deleted, leaving the session without any security. RACF rejects all access to RACF-protected resources. The DFS3662 message is displayed if the failing resource is a command. The DFS2469 message is displayed if the failing resource is a transaction. When a user signs on to an STSN device, the same user structure allocated during session allocation is used for the new user. IMS updates the security profile of the session and stores the signon information.

The user ID of a user that is signing on to an ETO Finance, SLU-P, or ISC device with a /SIGN command is a different name from that of the user structure name. Such users do not require suffixing by the Signon exit routine (DFSSGNX0) in order to support multiple signons, because the user structure for these devices was already created during the session initiation.

**Restriction:** Because the user structure allocated to a Finance, SLU-P, or ISC device cannot be changed, most of the options available to the Signon exit routine are not supported, and the work areas are not passed to the Signon exit routine.

#### Related Reading:

- For more information on using execution parameters, see *IMS Version 9: Administration Guide: System*.
- For information on using exit routines, see *IMS Version 9: Customization Guide*.

The DFS3650 message is displayed after a signon, and the DFS058 message is displayed after signoff. The user field in the DFS3650 message reflects the user structure's name rather than the RACF user ID. This is the same as for any other ETO terminal.

**Restriction:** Issuing the /SIGN command from STSN output-only devices is not allowed.

---

## Conversation Mode and Response Mode with ETO

ETO user structures are distinct from static terminal structures, because terminal status is maintained for each user rather than for each terminal. An IMS conversation at a static terminal is distinct from an IMS conversation at a dynamic terminal, even for the same user name. The conversation at a static terminal can be held, and must be released (resumed) at the static terminal. It cannot be moved to a dynamic terminal.

With ETO, an IMS conversation can be resumed at the same terminal or another dynamic terminal. Because the conversation is an attribute of the user structure, it normally follows the user to a different terminal when the user signs on to IMS. The following of the conversation attribute can be a cause of confusion, especially if the user is not aware of which terminals are static and which are dynamic. Also, if an exit routine selects different user structures for signons to different physical terminals, confusion can occur.

Resume Fast-Path response mode at the same static terminal. For ETO, resume Fast-Path response mode from the same or another dynamic terminal. This ability to resume the Fast-Path response mode from any dynamic terminal is similar to the situation with conversations described in the previous paragraph, and the same considerations apply.

### Conversation Mode

For ETO, conversations are associated with the user—not the terminal that initiates the conversation. Conversations are also associated with the terminal, but only while the user is signed on. By signing off, the user can continue a conversation on a different terminal. This flexibility requires the installation to address output formatting problems.

**Related Reading:** For information on how to resolve these problems, see "Delivering Output Messages to Non-Originating Terminals" on page 188.

Users in conversations that are not in response mode can sign off. Regardless of response mode, users in conversation can be automatically signed off through autosignoff or by using an MTO command. Any form of signoff leaves the terminal available for the next user. The conversation mode status follows the user to the next terminal or, with the Resource Manager and global status recovery mode (SRM=GLOBAL), on a different IMS in the IMSplex.

### Response Mode

Response mode is defined on the TERMINAL macro for static terminals, on the ETO user descriptor for dynamic (ETO) users, and on the TRANSACT macro for transactions. Also, response mode is either full function or Fast Path. You can also use response mode with conversation mode, if you are not running Fast Path. Response mode is primarily associated with the user and the transaction, rather than with the dynamic terminal.

## ETO with Conversation Mode and Response Mode

When a user is in response mode, the keyboard or input response is locked until the output reply is available. During this time, it is not possible to enter input at the terminal. Normal signoff and logoff commands are not allowed. However, these functions can occur automatically during abnormal session termination. This can happen in one of three ways:

- VTAM can detect an error and end abnormally (abend).
- The MTO can issue the IMS /CLSDST or /STOP command.
- IMS can autosignoff after the specified autosignoff interval.

Regardless of how signoff occurs, full-function response mode is not retained. If autosignoff occurs, the terminal is available for a subsequent signon by any remote terminal operator (RTO).

**Related Reading:** For more information on delivering messages to a different terminal than the originating terminal, see “Delivering Output Messages to Non-Originating Terminals” on page 188.



## Part 4. Multiple Systems Coupling

### Chapter 10. Overview of Multiple Systems

#### Coupling . . . . . 197

Multiple Systems Coupling Concepts and Terminology . . . . . 197

Physical Links . . . . . 197

Logical Links . . . . . 198

Logical Link Path . . . . . 199

The MSC Network and Routing . . . . . 200

Remote and Local Systems . . . . . 200

Flow of Data within Multiple Systems . . . . . 200

Message Routing . . . . . 201

Routing Path . . . . . 201

Logical Destinations . . . . . 202

Input, Destination, and Intermediate Systems

System Identifiers (SYSIDs) . . . . . 204

Routing Messages with the Destination Name

and SYSIDs . . . . . 206

Remote LTERMS . . . . . 208

Multiple Systems Coupling (MSC) Directed

Routing . . . . . 210

Remote Destination Verification . . . . . 211

### Chapter 11. Administering Multiple Systems

#### Coupling . . . . . 213

Design Considerations for Multiple Systems . . . . . 213

Minimizing Resource Consumption . . . . . 214

Balancing Resource Demand . . . . . 214

Planning for Conversational Processing . . . . . 215

Routing Exit Routines with Conversations . . . . . 216

Remote Destination Verification for

Conversations . . . . . 216

Saving Truncated Data in the SPA . . . . . 216

Conversation Termination . . . . . 217

Abnormal Conversation Termination . . . . . 217

System Definition for Multiple Systems Coupling . . . . . 217

Local System Definitions . . . . . 218

Defining Partner Systems . . . . . 218

Defining the Physical Link . . . . . 219

Defining the Logical Link . . . . . 219

Defining a Logical Path . . . . . 220

Setting Link Priorities for Remote Transactions . . . . . 220

Serial Transaction Processing in an MSC

Network . . . . . 221

Specifying Exit Routines . . . . . 222

How Network Definition Is Affected by

Multiple Systems . . . . . 223

Verifying Transaction Definitions Across Systems . . . . . 224

Using the Multiple Systems Verification Utility . . . . . 224

Verifying the System Definition Status Online . . . . . 224

Security Considerations for MSC . . . . . 225

Establishing Operating Procedures for Multiple

Systems . . . . . 227

Initializing Multisystem Communication . . . . . 227

Terminating Multisystem Communication . . . . . 227

IMS Commands That Affect MSC Operation . . . . . 228

Logical Link Assignments . . . . . 228

Restarting a Logical Link . . . . . 229

Commands That Help Control Resources . . . . . 229

Using the /DISPLAY Command . . . . . 230

Logical Link Path Control . . . . . 231

Recovery Considerations . . . . . 232

Message Recovery . . . . . 232

Stopped Transactions . . . . . 232

Application Program Abnormal Termination . . . . . 232

Dequeuing Messages, Responses, and

Transactions . . . . . 232

Monitoring and Tuning Multiple Systems . . . . . 233

Coordinating Performance Information . . . . . 233

Interpreting IMS Monitor MSC Reports . . . . . 234

Determining Cross-System Queuing . . . . . 234

Assessing the Effect of Link Loading . . . . . 235

Assessing Link Queuing Times . . . . . 236

Extracting Multiple-System Transaction Statistics . . . . . 236

Controlling the Log Merge . . . . . 236

Interpreting the Transaction Analysis Report . . . . . 237

MSC and IMSplex with Shared Queues: Migration

and Coexistence . . . . . 237

Message Routing Across MSC and IMSplex

Environments . . . . . 238

Migrating From an MSC Network to an

IMSplex Network . . . . . 240

Managing Remote Transactions for APPC and

OTMA When MSC and IMSplexes Coexist . . . . . 245

Avoiding Pseudoabend U0830 . . . . . 247

TM and MSC Message Routing and Control User

Exit Routine . . . . . 247

Terminal Routing . . . . . 248

Link Receive . . . . . 249

Program Routing . . . . . 249



---

## Chapter 10. Overview of Multiple Systems Coupling

Multiple Systems Coupling (MSC) makes it possible for transactions to be entered in one IMS and processed in another IMS. The responses can be returned to the terminals that entered the transactions or to other terminals. IMS uses MSC to route and control message traffic between connected IMS systems.

### **In this Chapter:**

- “Multiple Systems Coupling Concepts and Terminology”
- “The MSC Network and Routing” on page 200

---

### Multiple Systems Coupling Concepts and Terminology

MSC provides the ability to connect geographically dispersed IMS systems in such a way as to allow programs and operators of one IMS to access programs and operators of the connected IMS systems. Communication can occur between two or more (up to 2036) IMS systems running on any supported combination of operating systems.

MSC also provides a way to extend the throughput of an IMS beyond the capacity of a single CPU. This extension is possible if the IMS applications can be partitioned among IMS systems two ways:

- *Horizontal partitioning*: Applications execute in more than one IMS with database contents split between IMS systems.
- *Vertical partitioning*: Applications execute in one IMS with the complete database that they reference attached to that IMS. Transactions can originate in any IMS.

A *link* is a connection between two IMS systems. All links must be defined during the IMS system definitions for each IMS. There are two types of links: physical links and logical links.

- A *physical link* access method or hardware.
- A *logical link* is the mechanism through which a physical link is related to the transactions and terminals that make use of that physical link.

You can assign a logical link to a physical link during system definition, or the MTO can assign it dynamically during system execution.

- “Physical Links”
- “Logical Links” on page 198
- “Logical Link Path” on page 199

### Physical Links

A physical link is how the IMS systems connect to one other through access methods or hardware. You define a physical link with the SYSGEN macro MSPLINK. A maximum of 675 physical links are allowed in each IMS in a multiple systems coupling (MSC) network.

Multiple Systems Coupling supports three types of physical links:

- VTAM, usually if the IMS systems are in different data centers

## MSC Concepts and Terminology

- Channel-to-channel (CTC) adapter, usually if the IMS systems are in the same data center
- Memory-to-memory (MTM), if the IMS systems are in the same operating system

VTAM is an access method that usually uses a teleprocessing media connection. The CTC adaptor is a channel-to-channel hardware connection. The memory to memory (MTM) link is a software link between IMS subsystems that are running in the same operating system, and it is used primarily for backup and testing purposes. Physical link buffer sizes must be equal between the two IMS systems. Figure 25 illustrates the three types of physical links.

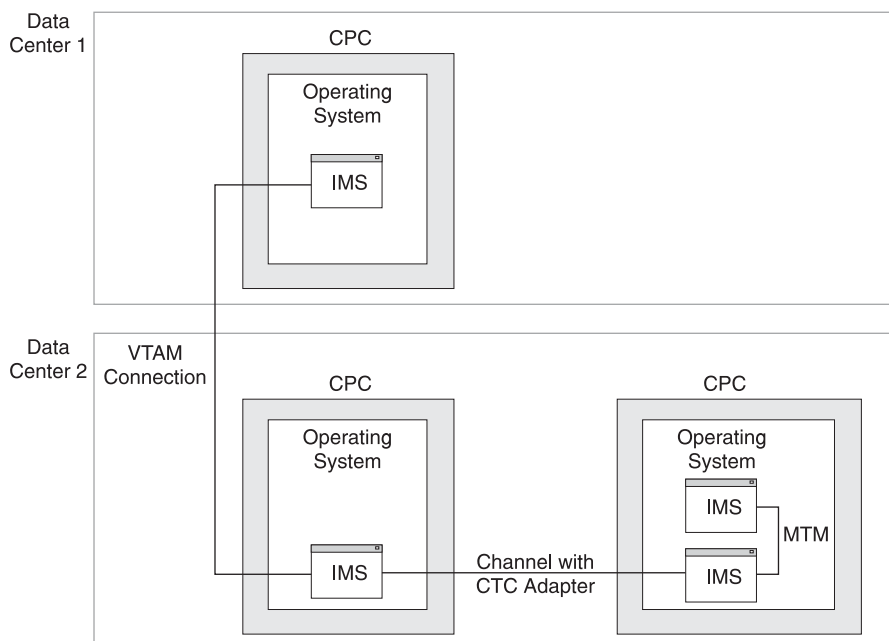

Figure 25. MSC Physical Link Types

## Logical Links

A logical link relates a physical link to the transactions and terminals that can use that physical link. Each IMS in an MSC network has one or more defined logical links. A maximum of 675 logical links are allowed for each IMS in the MSC network.

**Definition:** Two IMS systems that are defined to communicate with each other, each through a specific logical link, are called *partner systems*.

To establish connection between two IMS systems, each partner must have a logical-link definition. The two logical-link definitions must specify the same partner identifications and be assigned to the same physical link. The IMS system definition process assigns a number to each defined logical link. Logical link numbers are assigned sequentially, beginning with 1, in the order in which the links are defined. A logical link can be reassigned to a different physical link, but the two IMS systems must always communicate through a logical link partnership.

With VTAM, multiple sessions can use the link. During IMS system definition, you can specify how many sessions are to share the SDLC link. Each session that is activated becomes a logical link between partner systems.

The IMS system definition process does not require that a physical link be specified for each logical link. You can assign a physical link to the logical link online by using the IMS /MSASSIGN command. No communication between partners can occur until the assignment is made.

### Logical Link Path

A *logical link path* is the path between any two IMS systems. One or more logical link paths must be defined for each logical link. A logical link path is defined in the MSNAME macro and specifies the following:

- A system identification for the IMS in which messages using this path are to be processed.
- A system identification for the IMS being defined.

Each IMS in an MSC network has one or more unique system identifiers (SYSIDs) ranging from 1 to 2036. SYSID assignments are implicit, based on the logical link paths defined by MSNAME macros.

**Example:** Consider the two MSNAME definitions:

```
MSNAME  SYSID=(2,1)
MSNAME  SYSID=(3,1)
```

The first definition says that messages using this logical link path are processed in the remote system whose local SYSID is 2. The second definition says that messages using this logical link path are processed in the remote system whose local SYSID is 3. By using these definitions, the IMS system definition process assigns SYSID 1 to the IMS being defined and recognizes two remote systems with SYSIDs of 2 and 3. If a third path were defined with SYSID=(5,4), IMS would also assign SYSID 4 to the local system.

Transactions are assigned to logical link paths in the APPLCTN macro definition.

**Example:** Consider the following application definitions, each with one transaction code defined:

```
APPLCTN  PSB=A
          TRANSACT  CODE=A
APPLCTN  PSB=B,SYSID=(2,1)
          TRANSACT  CODE=B
APPLCTN  PSB=C,SYSID=(3,1)
          TRANSACT  CODE=C
```

The SYSID keyword identifies the logical link path to be used for the transactions associated with the application. Transaction A is considered to be a local transaction, because the absence of the SYSID keyword indicates transaction A is only processed by the IMS being defined. Transactions B and C are remote transactions. Relating the application definitions to MSNAME definitions, IMS would return responses from transactions B and C to the IMS defined as SYSID 1, unless the application program specified an alternative destination for the response.

If any logical terminals in a remote system are referred to by messages originating in the local system, the logical link definition must also include NAME macros to identify those remote logical terminals, unless directed routing is used.

## The MSC Network and Routing

These topics explain the following concepts necessary for MSC administration:

- “Remote and Local Systems”
- “Flow of Data within Multiple Systems”
- “Message Routing” on page 201
- “Routing Path” on page 201
- “Logical Destinations” on page 202
- “Input, Destination, and Intermediate Systems” on page 203
- “System Identifiers (SYSIDs)” on page 204
- “Routing Messages with the Destination Name and SYSIDs” on page 206
- “Remote LTERMs” on page 208
- “Multiple Systems Coupling (MSC) Directed Routing” on page 210
- “Remote Destination Verification” on page 211

### Remote and Local Systems

Figure 26 shows local and remote transactions and systems. When Transaction A is entered in IMS A, which is the local system, transaction A is processed locally. When Transaction A is entered on IMS B, which this time is the local system, it is sent across the MSC link to remote system IMS A and is processed remotely.

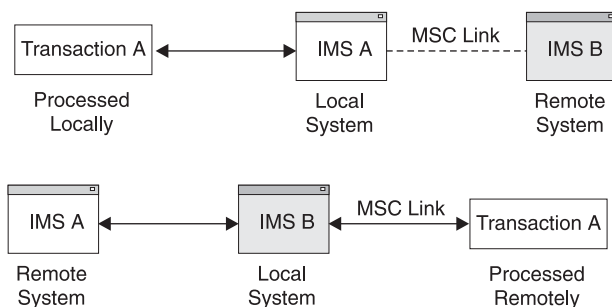

Figure 26. Remote and Local Transactions and Systems

#### Definitions:

- In an MSC network, a *local system* refers to a specific IMS where a message is entered. All other IMS systems are considered *remote systems* in regard to the specific local system.
- A *local transaction* is a transaction that is processed in the same IMS in which it is entered.
- A *remote transaction* is a transaction that is entered into a IMS from a terminal or a link that is not processed in that IMS.

In Figure 26, transaction A, when entered from IMS A and processed in IMS A, is considered a local transaction. When transaction A is entered from IMS B and sent across an MSC link to be processed in IMS A, it is considered a remote transaction.

### Flow of Data within Multiple Systems

The flow of a transaction in an MSC network requires additional steps as compared to one IMS. The general steps are illustrated in Figure 27 on page 201, and explained as follows:

- In the local system, a remote transaction entered from an LTERM is placed on the message queue of the local system with the destination of the remote transaction name (1).<sup>24</sup>
- MSC removes the message from the message queue (2), sends it across the MSC link (3), and places it on the message queue of the remote system (4).
- The remote system sends the message from the message queue to the application program to be processed (5). After the application program processes the message, the program sends a reply (6).
- The remote system places the reply message, with a destination of the output LTERM, on its message queue (7).
- MSC removes the message from the message queue of the remote system (8) and sends it back across the MSC link (9).
- MSC places the message on the message queue of the local system (10) and sends it to the output LTERM (10).

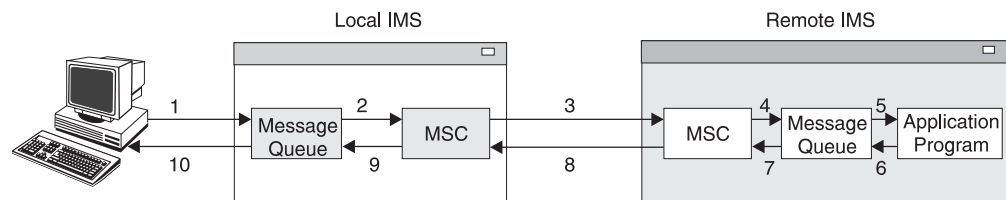

Figure 27. Remote Transaction Flow

## Message Routing

The message-routing function of MSC supports several types of message routing:

- Routing of transaction messages from a terminal in one IMS to an application program in another IMS. The transaction can be defined as recoverable, nonrecoverable, response mode, or conversational.
 

**Restriction:** Fast Path transactions across an MSC link are not supported. However, Fast Path transactions within the local system are supported.
- Routing of message switches from an LTERM in one IMS to an LTERM in another IMS and message switches between LTERMs in the same IMS. This support includes messages sent with a /BROADCAST command.
- Routing of response messages from an application program to the terminal that sends the transaction, or messages from an application program to an alternate terminal. Routing messages to alternate remote terminals (the transaction and the LTERM are in different IMS systems) requires that the alternate LTERM be defined as a remote LTERM. If directed routing or the TM and MSC Message Routing and Control User Exit routine is used, the alternate LTERM does not need to be defined as remote.
- Program-to-program switches between transactions in different IMS systems or within the same IMS.

## Routing Path

IMS passes messages from the local system to the remote system on a routing path. One or more IMS systems can be included in a routing path. In Figure 28 on page 202, IMS B has a path to IMS A and back (path BA). Similarly, back-and-forth paths exist between IMS B and IMS D (path BD), IMS B and IMS C (path BC), and IMS

24. The message is queued to the MSNAME associated with the specified remote destination.

## MSC Network and Routing

A and IMS D (path AD). A path can go through an IMS in order to get to another IMS, such as path CAD between IMS C and IMS D. More than one path can exist between the same two IMS systems. IMS C and IMS D have two direct paths, CD1 and CD2, in addition to the indirect path CAD. A total of 255 paths are allowed in one MSC network.

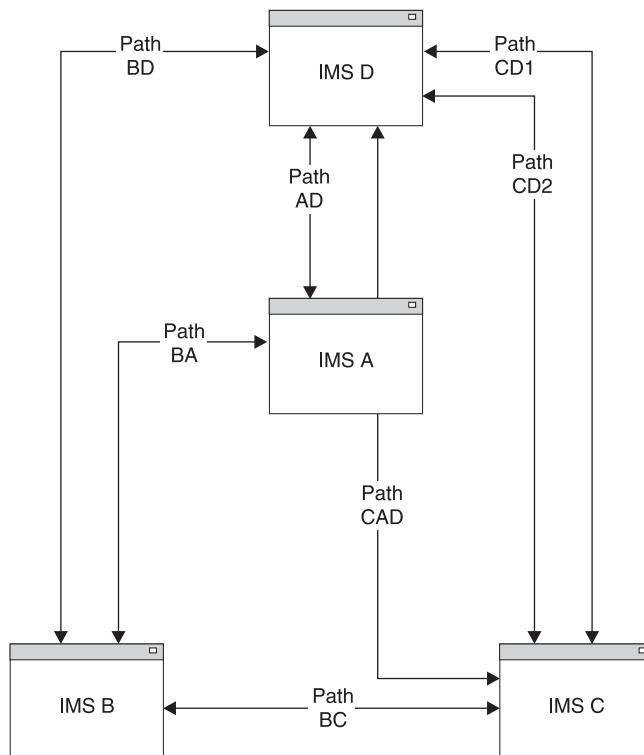

Figure 28. Routing Path

## Logical Destinations

Message routing for an MSC network uses logical destinations, as does a single-system environment. A destination is either an LTERM or a transaction code. A local destination resides in the local system, and a remote destination resides in a remote system. Within each local system, all local and remote destinations must be defined with unique names. In Figure 29 on page 203, all the local and remote destinations are uniquely defined within each local system. Destinations that are defined remotely are not also defined locally within the same IMS. Similarly, destinations that are defined locally are not also defined remotely.

The same destination names can be used for local destinations in different IMS systems that are connected by MSC. The destination names cannot conflict with the global intent of the destination within the MSC network. For example, in Figure 29 on page 203, TRANAB is a local transaction in IMS B and IMS A. It is a remote transaction in IMS C. IMS C is referencing the local TRANAB in IMS A only and not the one in IMS B. IMS C cannot remotely reference TRANAB in IMS B. The destination system that is referenced in a remote destination is determined by the system identification (SYSID) value.

**Related Reading:** For more information on SYSIDs, see “System Identifiers (SYSIDs)” on page 204.



With directed routing and the TM and MSC Message Routing and Control User exit routine, you can send messages from an application program to a remote destination that is not explicitly defined in the destination system. The validation of the destination name in the transaction processing system is delayed until the message arrives in the local system. Delaying this validation provides more flexibility in the resource naming requirements.

**Related Reading:** For more information on directed routing and the TM and MSC Routing and Control User exit routine, see *IMS Version 9: Customization Guide*.

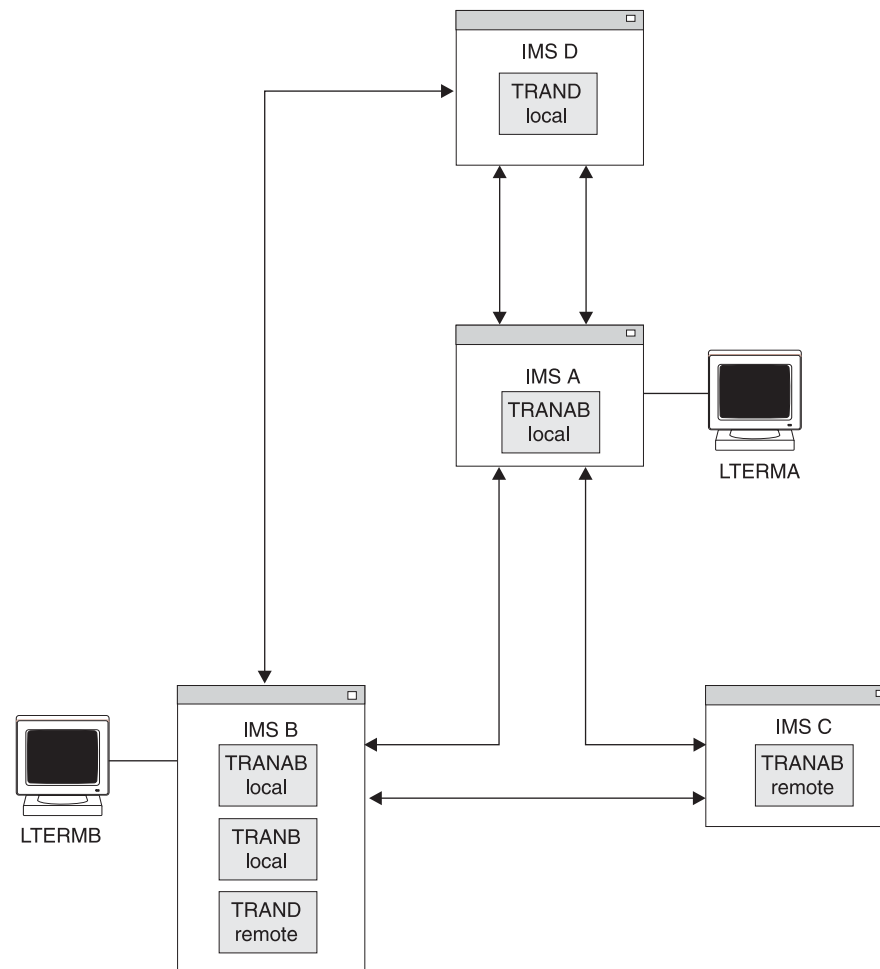

Figure 29. Logical Destinations

## Input, Destination, and Intermediate Systems

Depending on the message, an IMS can be either an input system, a destination system, or an intermediate system. For example, in Figure 30 on page 204, the transaction message originates from LTERMB in IMS B and is routed over path BD to TRAND in IMS D. IMS B is the input system and IMS D is the destination system. This message is called a primary message. When the message is processed by the application program in IMS D and a reply is returned to the input terminal in IMS B, this reply message is called a response. For this response message, the destination and input system is IMS B. The destination of the message is LTERMB in IMS B. The input that caused this response message is also from LTERMB in IMS B, which is the primary transaction.

## MSC Network and Routing

If a message is sent through one IMS and routed directly to another IMS for processing, the routing system is called the intermediate system. For example, if TRAND is sent from IMS B through IMS A to IMS D (path BAD), IMS A is the intermediate system and IMS D is the destination system. Similarly, IMS A and IMS D are intermediate systems for TRANC when TRANC is sent from IMS B through IMS D through IMS A to IMS C (path BDAC).

Remote destination names must be defined as remote in the input system and as local in the destination system. Intermediate systems, however, do not need to define the input, destination name, or the path back (a local SYSID) for the routed message. Only the path to the destination system needs to be defined. The path back might not even be through the intermediate system. Input and destination name checking is not performed on a message when it is routed through an intermediate system.

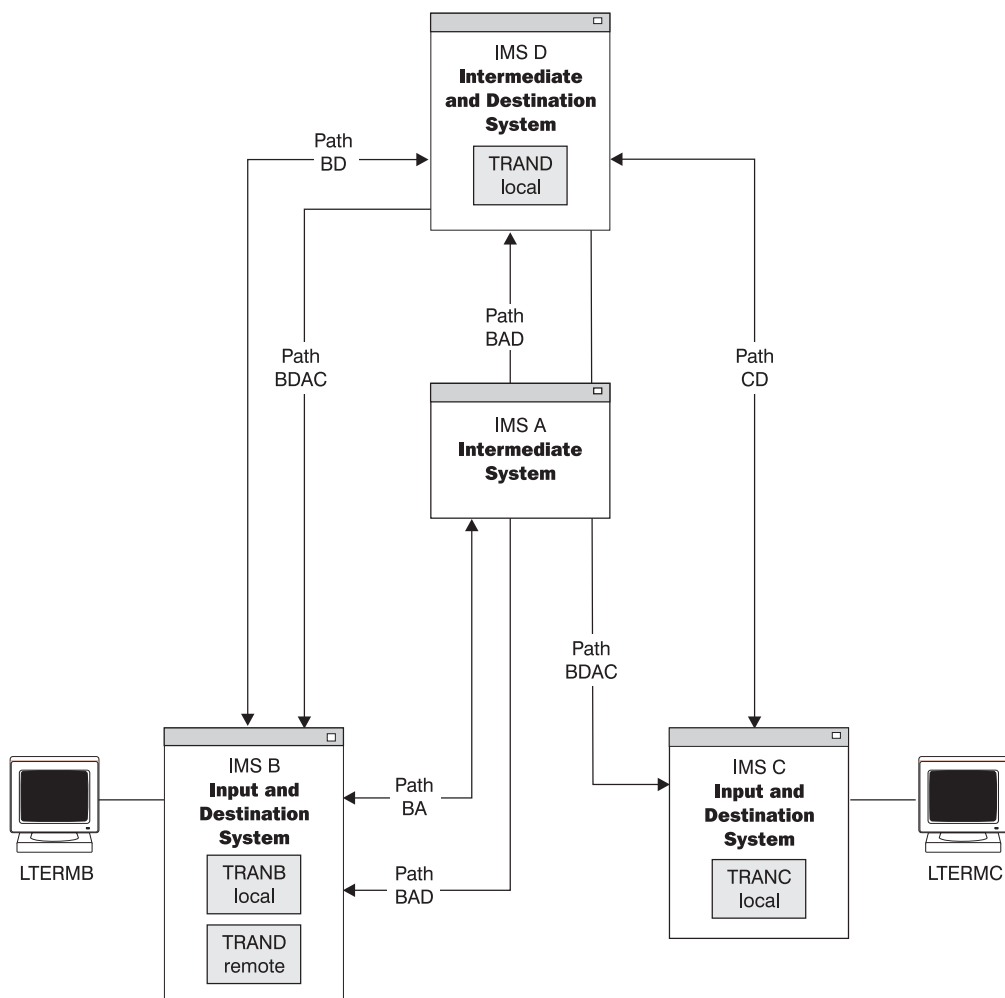

Figure 30. Input, Destination, and Intermediate Systems

## System Identifiers (SYSIDs)

Each IMS must be assigned at least one unique system identifier (SYSID) in the MSC system definition process. The SYSID is a two byte number between 1 - 2036. The SYSID is local to the owning IMS and remote to any other IMS in the MSC network. In Figure 31 on page 206, IMS B has local SYSIDs 1, 2 and 3. IMS A has local SYSID 4. IMS C has local SYSID 5. IMS D has local SYSIDs 6 and 7. Local

| SYSIDs are implicitly defined when MSNAME macros specify the paths to other  
| IMS systems. That is, the local SYSID value of the SYSID parameter on the  
| MSNAME macro determines which local SYSIDs are defined to an MSC system.

**Related Reading:** For more information on the MSNAME macro, see *IMS Version 9: Installation Volume 2: System Definition and Tailoring*.

In Figure 31 on page 206, IMS B has local SYSIDs 1, 2, and 3 because of the three MSNAME macros with local SYSIDs of 1, 2, and 3. Paths to other IMS systems are determined by the remote SYSID value on the MSNAME macro SYSID parameter. IMS B has three paths to remote SYSIDs 6 (IMS D), 7 (IMS D), and 5 (IMS C). IMS D and IMS B cannot route messages to IMS A, because they do not have paths to SYSID 4 (IMS A). IMS A does, however, have a path to SYSID 7 (IMS D) and SYSID 2 (IMS B). IMS A cannot send messages that originate in IMS A to SYSID 7 or SYSID 2, because the source SYSID (SYSID 4) is not recognized by IMS B or IMS D. In this configuration, IMS A can only function as an intermediate system for IMS B and IMS D. Another path (MSNAME) must be defined for IMS B to communicate with IMS A and IMS D.

**Related Reading:** For more information on paths and how a transaction uses a path, see “Logical Link Path” on page 199.

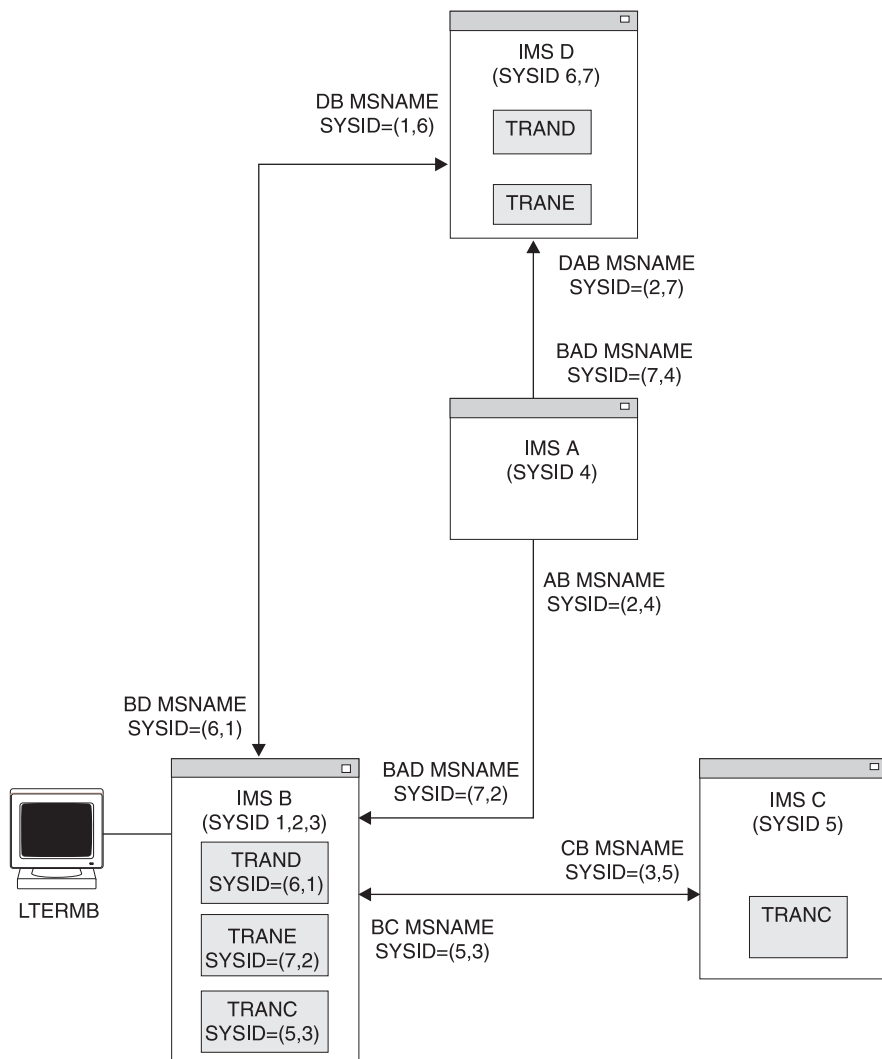

Figure 31. System Identifiers (SYSIDs)

### Routing Messages with the Destination Name and SYSIDs

Messages in an MSC network contain information that makes it possible to route the message between IMS systems. When a remote transaction is entered from an LTERM, a transaction message is built and queued on the message queue. This message contains information that is needed to route the message to its remote destination:

- Remote destination name (transaction code)
- Local or source LTERM name of the LTERM that entered the transaction
- Remote SYSID value
- Local or source SYSID value

If the transaction is processed by the application program and secondary messages are sent to other transactions (program-to-program switches), these messages have the destination name and SYSID of the switched-to transaction. The source (origin) name and SYSID remain the same. That is, the source SYSID and name never

change. This facilitates sending the response message back to the input LTERM, regardless of where the transaction is processed.

Any IMS that locally processes a message that is received from a remote system must have a local SYSID defined to it that is the same as the remote SYSID of the message. It must have a path back to the source (origin) of the message. In Figure 32 on page 208, if TRANA is entered from LTERMB in IMS B, it is sent across the path MSNAME=(4,2) to IMS A. The destination name and SYSID of the message are TRANA and 4. The source name and SYSID are LTERMB and 2. IMS A accepts the message and processes it. It has SYSID=4 defined as local and has a path back to IMS B with the destination SYSID=2. If TRANA in IMS A issues a program-to-program switch to TRAND in IMS D, the destination name and SYSID are TRAND and 5. The source name and SYSID remain LTERMB and 2. IMS D accepts and processes the transaction. The transaction has SYSID=5 defined locally and has a path back to IMS B with destination SYSID=2.

If TRAND in IMS D sends a response back to input LTERMB, the response message has a destination name and SYSID of LTERMB and 2, and the source name and SYSID are also LTERMB and 2.

The input LTERM, LTERMB, is never defined as remote in IMS A or IMS D, yet the response message is returned to LTERMB in IMS B. IMS carries the originating LTERM name and SYSID in the primary message and all secondary messages. IMS knows where to route the response message when the application program responds to the input LTERM.

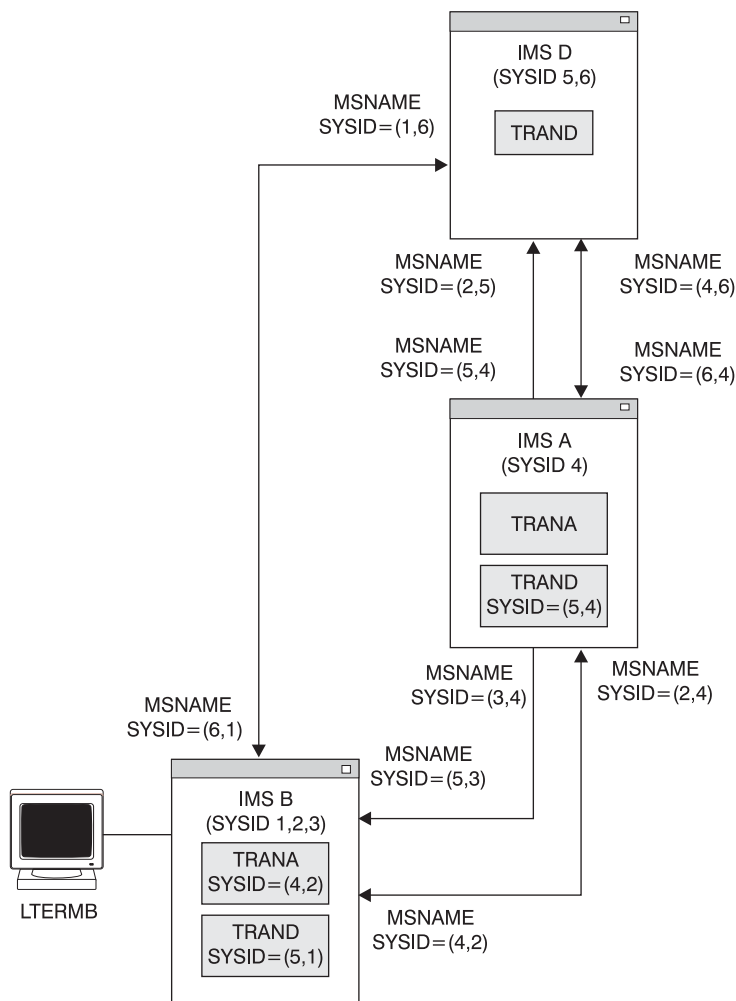

Figure 32. Message Routing

## Remote LTERMs

**Definition:** A *remote LTERM* is a logical terminal that does not reside on the local system.

**Recommendation:** Define the input LTERM as a remote LTERM only to send message switches, remote broadcasts, or messages from an application program to an alternate remote terminal (alternate PCB).

You can define remote LTERMs by using ETO MSC descriptors. The ETO MSC descriptor relates remote LTERMs to statically defined MSC links.

**Related Reading:** For more information on ETO MSC descriptors, see “MSC Descriptor Format” on page 171.

To help return response messages to the input (source or origin) LTERM, IMS carries the source LTERM name and SYSID in the remote message. To send a response message to an LTERM other than the source LTERM, you must define a remote LTERM. In the remote system, define NAME macros that have the name of

the local terminal in the local system. Associate the NAME macro with the MSNAME that defines the destination SYSID of the local system.

For example, in Figure 33 on page 210, IMS A has local LTERMA, IMS B has local LTERMB, and IMS D has local LTERMD. IMS B can send message switches and remote broadcasts from LTERMB to LTERMD because LTERMD is defined remotely in IMS B. LTERMD is not actually defined with SYSID=(5,2), but it assumes those SYSIDs when the message is issued. LTERMD is associated with MSNAME BAD, which is defined with SYSID=(5,2) in IMS B. This association is established by placing the NAME macro for LTERMD after the following MSNAME macro:

```
BAD MSNAME SYSID=(5,2)
    NAME LTERMB
```

This naming differs from remote transaction definitions, which are explicitly defined with remote and local SYSIDs.

Also, LTERMA in IMS A can send message switches or remote broadcasts to LTERMD in IMS D. Similarly, LTERMD in IMS D can send message switches or remote broadcasts to LTERMA in IMS A. Both IMS A and IMS D have remote LTERM specifications for the other system's local LTERM.

TRAND in IMS D can send alternate messages to LTERMB in IMS B or to LTERMA in IMS A. MSNAMEs are defined with names for the purpose of:

- Displaying the queue counts for the named logical link path
- Stopping the sending of all messages from a terminal except those continuing a conversation
- Starting the logical link path
- Purging the logical link path in an MSC network for which input is stopped
- Allowing application programs to use directed routing
- Reassigning using the /MSASSIGN command

In Figure 33 on page 210, the name of each MSNAME is the two-character name preceding MSNAME.

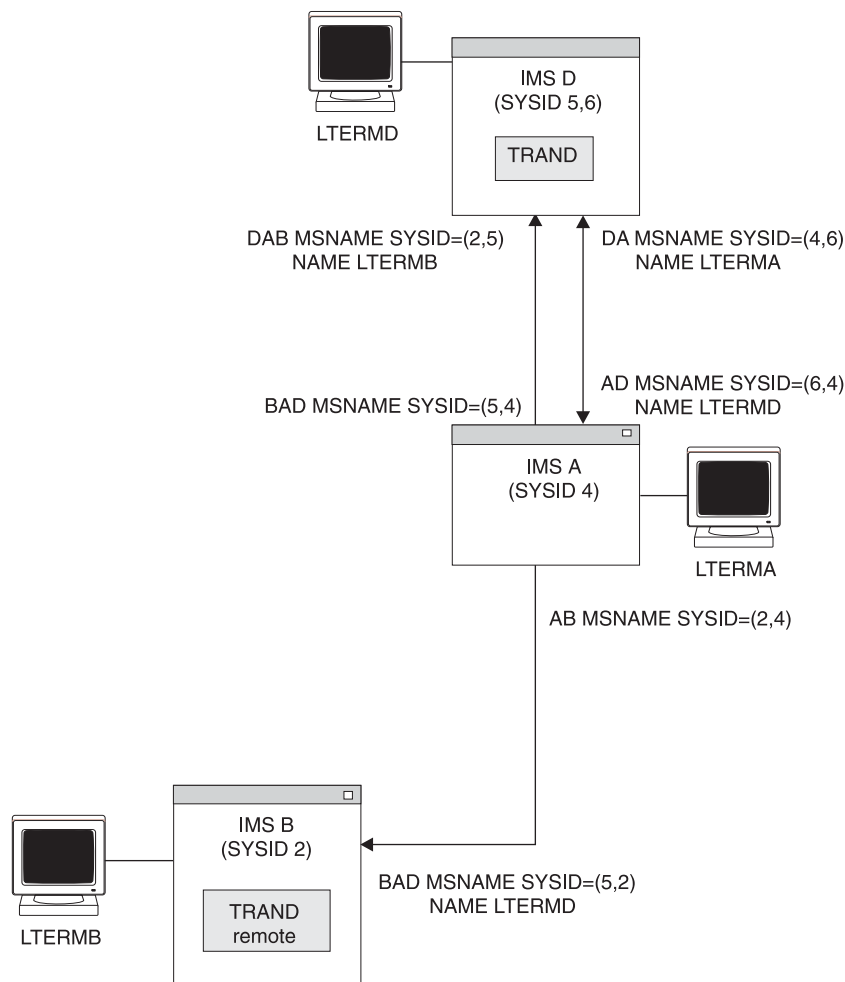

Figure 33. Remote LTERMs

## Multiple Systems Coupling (MSC) Directed Routing

*MSC directed routing* is a function of MSC that allows an application program to specify the IMS name (MSNAME) and destination within that IMS for a message to an LTERM or an application program. The receiving application program can determine the MSNAME of the IMS that originally scheduled it. With directed routing, the specified remote destination (a transaction or an LTERM) in another IMS does not need to be declared explicitly in the IMS system definition for the sending IMS. These logical (local) names for terminals enable different IMS systems in the MSC network to use the same logical names for terminals and transaction codes. Names must still be unique within a given IMS. The Multiple Systems Verification utility (DFSUMSV0) cannot detect errors associated with MSC directed routing.

### **Restrictions:**

- MSC directed routing does not support a program-to-program switch between conversational transactions.
- MSC directed routing does not support a program-to-program switch from a nonconversational transaction to a conversational transaction. For example, a



conversational transaction in System A cannot use directed routing to perform a program-to-program switch to invoke a conversational transaction in System B.

- Response mode cannot be propagated on a DL/I ISRT call in a directed routing transaction.

**Related Reading:** For more information on directed routing, see *IMS Version 9: Application Programming: Transaction Manager*.

### Remote Destination Verification

To maintain system integrity and prevent errors, an IMS in an MSC network verifies all specified destinations, unless MSC directed routing is used. When MSC directed routing is used, IMS only ensures that a program-to-program switch is not being performed from a nonconversational transaction to a conversational transaction. Remote destination verification occurs when a message is received from a terminal or on receipt of an application program reply if a remote destination is specified for the message. Destination verification occurs as follows:

**Destination      Verified For:**

**LTERM**            Destination type: The original destination must have been a logical terminal.

**Transaction**    Destination type: The original destination must have been a transaction.

Transaction attributes: The following attributes must be consistent in the transaction definitions in the input and destination systems:

- Single segment or multiple segment
- Recoverable or irrecoverable
- Conversational or nonconversational

The SPA size for a conversation from a remote system cannot be changed except by the remote system on an insert.

When an invalid destination is recognized, IMS cancels the message, sends an error message to the input terminal and to the master terminal of the local system, and logs an invalid request. If the message is conversational, the Conversation Abnormal Termination (name) exit routine is called in the input system, and the conversation is terminated.



---

## Chapter 11. Administering Multiple Systems Coupling

These topics describe the system administration activities required when you connect two or more IMS online systems in a network using MSC.

LU 6.2 application programs can process transactions on remote IMS systems. ETO also supports remote LTERMs.

**Related Reading:** For more information on remote LTERMs, see “Remote LTERMs” on page 208.

### **In this Chapter:**

- “Design Considerations for Multiple Systems”
- “Planning for Conversational Processing” on page 215
- “System Definition for Multiple Systems Coupling” on page 217
- “Verifying Transaction Definitions Across Systems” on page 224
- “Security Considerations for MSC” on page 225
- “Establishing Operating Procedures for Multiple Systems” on page 227
- “IMS Commands That Affect MSC Operation” on page 228
- “Recovery Considerations” on page 232
- “Monitoring and Tuning Multiple Systems” on page 233
- “MSC and IMSplex with Shared Queues: Migration and Coexistence” on page 237
- “TM and MSC Message Routing and Control User Exit Routine” on page 247

---

## Design Considerations for Multiple Systems

The major design goals for MSC are:

- Minimizing resource consumption by defining suitable connections between the systems
- Balancing resource demand by distributing functions among systems to obtain acceptable performance
- Programming design considerations for multisystem conversational transactions

The design and tuning recommendations that apply to a single IMS system are applicable to each IMS system in an MSC environment. Resource demand and consumption are taken into account when defining systems that are part of an MSC configuration.

An IMS transaction that is processed in a local system uses the same hardware and software resources that it would in a non-MSC environment. Transactions that are processed in a remote system require additional resources. In addition to resources used to transmit the transaction over physical links to the remote processor and to receive the response from the remote processor, resources are needed for message queuing and logging. Performance considerations are directly related to minimizing the resources consumed by remote processing and balancing the resource demand between several processors in an MSC configuration.

### Minimizing Resource Consumption

To minimize resource consumption, do each of the following:

- Design the environment so that as many transactions as possible are processed locally.
- Provide physical links that go directly from local to remote systems; no intermediate systems should be involved in the transaction routing process. Transactions that must be routed through intermediate systems require additional processor activity, message queue activity, and logging activity.
- Design the message queue buffer pool in each processor to eliminate unnecessary message queue I/O activity.
- Define the physical link buffer sizes large enough to hold the message prefix plus all the segments of most messages. Also, the queue buffer size should be large enough to hold the largest segment that is inserted to the message queue by a transaction as response to the input terminal.

### Balancing Resource Demand

In an MSC environment with two or more processors, try to distribute the workload in a way that avoids excessive use of any one processor. You can distribute the workload by distributing IMS applications and their associated transactions and terminals between the available processors. Depending on the complexity of the application and the capability of the processor, you can avoid overloading any single processor.

If the current design of the databases is such that the databases and their associated applications cannot be distributed across the available processors, you can:

- Duplicate inquiry-only databases; this allows more than one system to reference the whole of the database. (This is called vertical partitioning.)
- Split the databases into several component databases. (This is called horizontal partitioning.) The component databases must be completely independent for distribution among the available processors. For example, it might be possible to divide a database by key range intervals. The new databases and their associated applications can then be distributed among the existing IMS systems, and you can use the Terminal Routing exit routine to route incoming transactions to the correct IMS system. Another possibility is to divide the database by geographic area. Each IMS system could process the transactions that refer to the databases for its own geographic area and route transactions that refer to a remote geographic area.

In addition to balancing the workload across processors, you might also need to balance the workload on physical links. This occurs when a physical link between two systems is of the SDLC type and multiple physical links have been installed. You can balance the workload on physical links by:

- Specifying, during IMS system definition, proper logical link paths and logical links for each remote application.
- Using a user-written Terminal Routing exit routine to distribute the transaction load on each of the alternative physical links.

## Planning for Conversational Processing

Conversational processing is available to terminals that are attached to any IMS in an MSC network to the same extent as if they were in a single-system environment.

The following differences apply to conversational processing in an MSC network:

- All transactions used in a conversation must be defined as conversational in each IMS of the MSC network.
- The input system controls the conversational resources for the duration of the conversation. When the input system receives a conversational transaction, it inserts the scratch pad area (SPA) as the first message segment, and routes the message to the destination application program.
- Any system in the MSC network can process any step in the conversation.
- Program-to-program switches can be routed from system to system.
- SPAs that are used in multisystem conversations must follow these rules:
  - For the SPA ISRT, conversational program-to-program switches can occur to a transaction with a SPA that is equal, larger, or smaller in size.
  - For transactions sent to IMS Version 5.1 systems or older (using MSC links), the following requirements apply:
    - If the SPA ISRT occurs on a remote system, the SPAs must be the same size.
    - If the SPA ISRT is being returned to the input terminal, the SPA must be less than or equal to the SPA size of the transaction issuing the ISRT.
  - The minimum size of a SPA is 16 bytes (X'10'), and the maximum size is 32767 bytes (X'7FFF').

Generally, terminal operators and application programs are unaware of whether a conversation is multisystem.

### Exceptions:

- Suppose a conversational program inserts a message to a response alternate PCB in a remote system. By implication, this destination is in the input system and is verified by the input system. Destination verification in this case involves confirming that the specified logical terminal is still assigned to the input terminal. If the logical terminal has been reassigned, the input system activates the Conversation Abnormal Termination exit routine, and terminates the conversation. The status code that is returned to the application program is blank, indicating success. This status code is blank even when the actual result is unsuccessful due to the condition described.
- Suppose an application program executing in a system other than the input system uses the SPA to specify a transaction code, thereby passing conversation control to another program. If the specified transaction code is invalid, the input system activates the Conversation Abnormal Termination exit routine, and terminates the conversation. No status code is returned to the application program.

MSC support for APPC/IMS and OTMA includes the following IMS transaction types:

- Conversational
- Nonconversational
- Response mode
- Non-response mode

**Restriction:** MSC does not support Fast Path.

### Routing Exit Routines with Conversations

You can use the program routing and link routing entry points of the TM and MSC Message Routing and Control User exit routine to input messages that starts a conversation. It is not applicable at any other conversational step, because the application program, not the input terminal, provides the destination for continuation of the conversation.

### Remote Destination Verification for Conversations

Destinations for program-to-program switches are verified in the system in which the program requesting the switch executes, except where MSC directed routing is used. When MSC directed routing is used, IMS ensures only that a program-to-program switch is not being performed from a nonconversational transaction to a conversational transaction. If valid, the system sends the SPA and the message directly to the destination transaction. If invalid, the system returns a status code to the application program.

Destination verification for a message to the input terminal is performed by the input system. The specified logical terminal must still be assigned to the input terminal. The input system also verifies, except when MSC directed routing is used, the next transaction that is specified in the SPA. If the destination is invalid, the input system invokes the Conversation Abnormal Termination exit routine and terminates the conversation. No status code is returned to the application program.

### Saving Truncated Data in the SPA

The SPA=STRUNC option on the TRANSACT macro applies to conversations that use program switches to other transactions that have different sized SPAs:

- If you use the SPA=STRUNC option, IMS preserves all of the data in the SPA, even when a program switch is made to a transaction that is defined with a smaller SPA. The transaction with the smaller SPA does not see the truncated data. However, when this transaction switches to a transaction with a larger SPA, the truncated data is used. IMS tracks the longest data that is inserted to the SPA to determine the truncated data length.

**Example:** If you have the three transactions:

```
TRANA SPA=100  
TRANB SPA=50  
TRANC SPA=150
```

If the application program for TRANA switches to TRANB, the last 50 bytes of the SPA for TRANA are not sent to TRANB. If the application program for TRANB subsequently switches to TRANC, the SPA that is received by TRANC contains the following 150 bytes:

- The first 50 bytes from the SPA that was inserted by TRANB
  - The second 50 bytes from the second 50 bytes that was inserted by TRANA
  - The third 50 bytes are binary zeros.
- If you do not use the SPA=STRUNC option, the truncated data is lost. In the previous example, the second 50 bytes that is received by TRANC would be binary zeros.

**Restriction:** Truncated SPA data from a previous transaction is lost if it is sent using MSC to an IMS 5.1 (or earlier) system.

## Conversation Termination

A conversation can be terminated by either the application program or the terminal operator. An application program terminates a conversation by inserting a message to the input terminal with a SPA that contains either blanks as the transaction code or the transaction code of a nonconversational transaction.

A conversational transaction can also be terminated by the /EXIT command.

An IMS shutdown does not terminate conversations. The conversation is continued after IMS restarts, unless an IMS cold start occurs or the conversation is terminated by an operator command such as /EXIT. If the input system is shut down and subsequently cold starts, all the conversations that it controls are lost. If using Resource Manager (RM) and the status recovery mode is GLOBAL, an IMS conversation can survive an IMS cold start because the status is stored in RM. The input system cancels any conversational messages it receives for input terminals that were previously involved in active or held conversations. IMS retains conversations over a restart. An IMS cold start is an unusual procedure, and can cause many problems beyond losing conversation state.

If a remote system is shut down when a conversational step is processing or in its queue, and it is subsequently cold started, all references to the conversation are lost. A conversation that is lost in this way must be specifically canceled in the input system by the /EXIT command.

## Abnormal Conversation Termination

A conversation is abnormally terminated if any one of the following events occur:

- The conversational application program abnormally terminates.
- An invalid destination is recognized in the input system or in the remote system (for a conversation response, a program-to-program switch, or in the SPA).
- A conversational message is inserted into a terminal whose conversation was terminated.
- Destination verification fails for a conversational message.
- No output was generated in the application program.

The conversation's SPA (along with an indication of the cause of termination) is passed to the Conversation Abnormal Termination exit routine in the input system.

---

## System Definition for Multiple Systems Coupling

You need to define, using system definition macros, transaction codes for each IMS system that has any part in transaction entry or processing. An individual system can play several roles. It can be the input system, it can be an intermediate system responsible for routing transactions, or it can be a destination system in which the transaction is processed.

To generate an IMS online system that includes MSC facilities, your IMS system definition must include three macros: MSPLINK, MSLINK, and MSNAME.

**Related Reading:** For more information on the MSPLINK, MSLINK, and MSNAME macros, see *IMS Version 9: Installation Volume 2: System Definition and Tailoring*.

Using MFS is the same in an MSC network as in a single-system environment. If a message is created in one IMS for a terminal that is attached to another IMS, the

## System Definition for Multiple Systems Coupling

required message and format descriptions must be available to the IMS to which the terminal is attached, and definitions with the same name must be defined identically in each IMS.

### Local System Definitions

When the MSC network is defined, the items that are defined for each local system include:

- All transactions entered or processed by that system
- All logical terminals that are attached to that system and all logical terminals in remote systems that are referenced by transactions processed in that system, or by terminal operators, unless a Program Routing exit routine is used
- The physical and logical connections between that system and the remote systems that share in the processing of the specified transactions

The system definition macros that you need to prepare in each system are summarized in Table 13. The first macro you use is IMSCTRL. Using the MSVID keyword, you assign a number in the range from 1 to 255 as a unique identifier of that system. This causes a control block, DFSMSxxx, to be built for use with the Multiple Systems Verification utility. (The 3-digit suffix, xxx, matches the MSVID parameter; one unique control block exists for each system in the MSC network.) This offline utility helps verify that system definitions for all partner systems are consistent. The IMSMSV procedure is generated in IMS.PROCLIB in order to execute this utility.

Table 13. Summary of Macros for Multiple Systems

Resource	Identification	Macro	Number Coded
System	System ID	IMSCTRL	1
Programs	PSB name	APPLCTN	1 per PSB
Local transactions	Transaction code	TRANSACT	1 or more per APPLCTN
Remote transactions	Transaction code	TRANSACT	1 or more per APPLCTN in a remote system
Exit routines	Exit routine type	COMM	1
Physical connections	Physical link name	MSPLINK	1 per connection
Logical connections	Logical link name	MSLINK	1 per MSPLINK <sup>1</sup>
Routing names	Logical path name	MSNAME	1 or more per MSLINK
Local terminals	LTERM name	NAME	1 per local terminal
Remote terminals	LTERM name	NAME <sup>2</sup>	1 per remote terminal

**Notes:**

1. Multiple-session SDLC links that are VTAM have additional MSLINK macros.
2. Define with an ETO MSC descriptor if the corresponding local terminal is an ETO terminal.

### Defining Partner Systems

A relationship exists between the three system definition macros (MSPLINK, MSLINK, and MSNAME) that define the names of connections between systems and the logical names that are used in commands.



### Defining the Physical Link

You can define three types of physical links to connect IMS systems. Your choice depends on the hardware that is required for each of the links. The choices are:

- Channel-to-channel (CTC)
- Memory-to-memory (MTM)
- VTAM

You use the MSPLINK macro to declare which type of physical connection you are going to use. You must declare all physical connections that can potentially be used, even if several might be for backup purposes or might not be intended for continual use. You must declare the physical link for partner systems in both system definitions. Using the TYPE keyword, declare the kind of physical link to use.

Assign a name to the MSPLINK macro; for example, LINK1. This name is used for logical link definition to match a connection between systems with the physical device or transmission technique that is to be used.

If the type is CTC, add a DD name and an address parameter value. Also specify a buffer size with the BUFSIZE keyword. This size must be equal for each end of a physical link. Use at least the size of the largest message segment that is to be transmitted across this physical link. The minimum size is 160 bytes. If the type is SDLC using VTAM, a minimum of 208 bytes is required for BUFSIZE. These buffer sizes are allocated from the communications input/output pool. Use the COMM keyword on the BUFPOOLS macro in order to allocate additional space for buffers for SDLC links. If part of a conversation is to be passed from one system to another, use the maximum scratch pad area (SPA) size, if that SPA size exceeds the message segment size.

APPC and OTMA transactions that are transmitted over MSC links need larger link buffers in order to accommodate the APPC and OTMA message prefix and the IMS extended prefix. The BUFSIZE parameter of the MSPLINK macro must specify a buffer that accommodates a prefix of 500 bytes. MSC non-VTAM links require a minimum buffer size of 160 bytes. MSC VTAM links require a minimum of 208 bytes and allow a maximum buffer size of 30720 bytes.

For SDLC that uses VTAM, you must supply a NAME keyword that matches the label on the VTAM APPL statement for the remote system. The NAME keyword and the VTAM APPL statement both specify the VTAM node name.

The label on the VTAM APPL statement also serves as a default value for the ACBNAME parameter on the same statement. Regardless of whether you use the default value for the ACBNAME parameter, this value must match the APPLID parameter on the IMS COMM macro.

The SESSION parameter indicates the number of parallel sessions that can be active for the physical link.

### Defining the Logical Link

The logical link definition is defined with the MSLINK macro, and has two parameters. The first parameter uses the PARTNER keyword and requires you to give a two-character identifier to represent a logical connection with the link of the same identifier in the partner system. For example, if BC is the partner

## System Definition for Multiple Systems Coupling

identification in one logical link defined by the MSLINK macro, this same identifier is in the MSLINK macro of the partner system.

The second keyword, MSPLINK, enables you to match the type of physical connection to be potentially used with this logical link:

- When the physical link type is CTC or MTM, one MSLINK macro exists for each kind of physical connection.
- When the physical link type is SDLC that was VTAM parallel sessions, multiple logical links can be assigned to one physical link. For example, System\_B and System\_C can have two logical links, one using MTM and the other CTC; System\_C and System\_D can have two logical links, both of which use one VTAM physical link.

You can define a maximum of 676 logical links for each IMS.

### Defining a Logical Path

When the operator connects two systems, a choice of physical connection type might be possible, therefore the logical link name is used. The MSNAME macro lets you define that logical path name. The SYSID keyword is used to declare the two systems that are joined in a pathway. You select the 1-digit identifiers from the range 1 to 2036, one for the remote system and the other for the local system. For example, (1,3) specifies that any message using this path is being sent to the remote system number 1, and that the local system number is 3.

The MSNAME macro can be followed by a set of NAME macros on which you can specify the LTERM names for terminals that are in remote systems. You do not need to declare every terminal in the remote system that is entering transactions, but only those that enter traffic destined for this local system. If the LTERM in the remote system is for an ETO terminal that enters transactions destined for this system, define the LTERMs using ETO MSC descriptors instead of NAME macros.

### Setting Link Priorities for Remote Transactions

A remote input transaction might have a different scheduling priority in the destination system from that defined for it during system definition of the originating system. This means there could be a long wait for a response, even though the remote transaction had a high priority when it was defined with the SYSID= parameter of the TRANSACT macro. You can assign priorities to remote transactions using the PRTY= keyword on the TRANSACT macro during system definition in the destination system.

**Example:** In Figure 34 on page 221, Terminal 1 is sending a remote transaction (ASMB1) to System B.

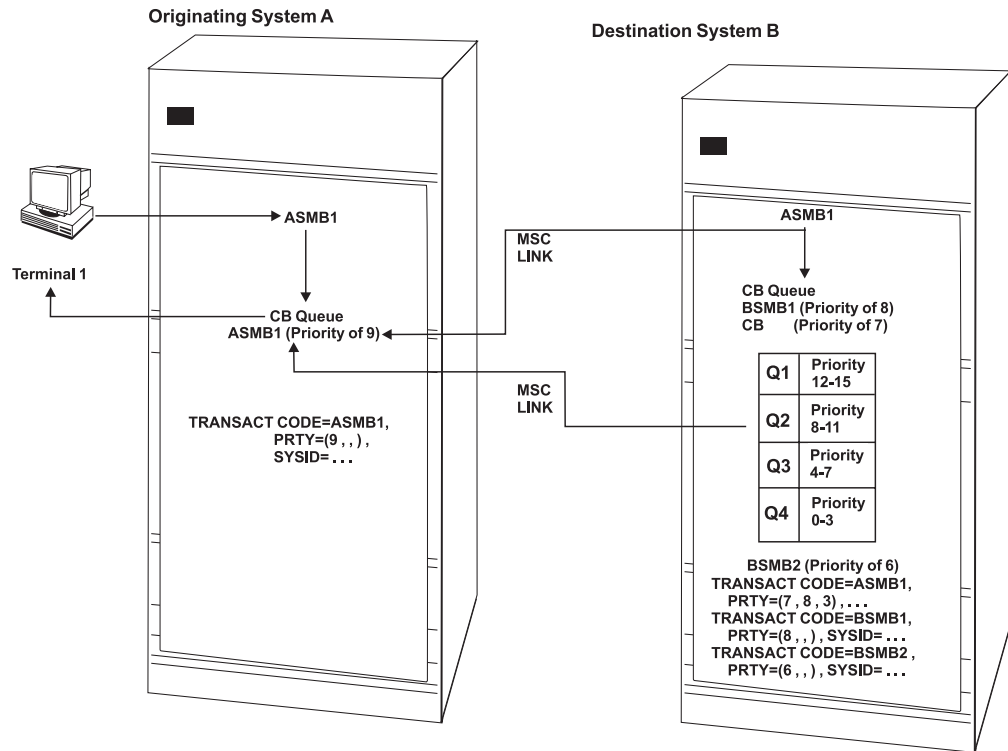

Figure 34. Link Priorities for a Remote Transaction

In IMS system A, this transaction is enqueued to a control block (CB) and has a priority of 9 (defined with the SYSID= parameter). When ASMB1 is sent to system B, it becomes a local transaction and is processed. When the message router is called to send a response, it enqueues the response on the control block that represents the MSC link. If ASMB1 is defined in system B with a priority of 7, all transactions with priorities of 12-15 (in queue 1) are processed first, and 8-11 (in queue 2) are processed next. The ASMB1 (with a priority of 7 in queue 3) is processed next. However, as shown in the figure, the limit priority can be set at 8 and the limit count can be set at 3. As a result, when the number of message queues to be processed reaches 3, the priority of ASMB1 is changed to 8, and subsequent responses are placed on queue 2. On system B, all messages for BSMB1 are sent before responses are sent. Messages for BSMB2 are sent last in this example.

In a shared queues environment, however, priority only applies to messages received from the MSC link to be processed. Priority does not apply to response messages (messages going back to the input system) because the coupling facility does not have the four queues. Instead, all response messages are sent FIFO.

## Serial Transaction Processing in an MSC Network

Serial transactions are processed in the order in which they are received relative to other transactions of the same type. You can ensure serial processing of transactions in remote MSC IMS systems by taking the following steps:

- Define the transaction as serial in both the local and remote MSC IMS systems.
- Restrict the transactions to a single logical link path between the local and remote MSC IMS systems.
- Send all serial transactions of the same type to the same remote MSC IMS for processing.

## System Definition for Multiple Systems Coupling

Serialization is not preserved for transactions that:

- Are sent across different logical link paths
- Originate from different MSC IMS systems
- Are processed in different remote MSC IMS systems

### The PRTY= Keyword and Output Messages of Serial Transactions in an MSC Network

The serial processing of the output messages of a serial transaction can become unpredictable in an MSC network if the *normal* and *limit* parameters of the PRTY= keyword are not equal in the TRANSACT macro.

If the *normal* and *limit* parameters are not equal and the number of output messages on a message queue becomes equal to or greater than the value of the *limit\_count* parameter of the PRTY= keyword, output messages received by a remote MSC IMS system after the *limit\_count* value has been reached might be processed before messages received earlier by the remote MSC IMS system.

**Related Reading:** For more information on the PRTY= parameter of the TRANSACT macro, see the Transact macro topic of the Macros chapter in *IMS Version 9: Installation Volume 2: System Definition and Tailoring*.

## Specifying Exit Routines

This topic describes how to specify exit routines used with MSC.

**Related Reading:** For an introduction to the TM and MSC Message Routing and Control User exit routine, see “TM and MSC Message Routing and Control User Exit Routine” on page 247.

### Routing Messages with DFSMSCEO

The TM and MSC Message Routing and Control User exit routine (DFSMSCEO) is not included in the system definition process. Therefore, incorporate DFSMSCEO in IMS.SDFSRESL.

The terminal routing entry points are invoked in the input system, possibly changing the destination. When transactions arrive at an IMS across the MSC link, the link-receive entry points can be invoked. These entry points can change the destination again. Because destinations can be changed at so many different points, clearly document how the destinations are changed, and explain the reasons for the new destinations, which are used for processing. You might need to correlate the transaction code changes as information for master terminal operators so that they can interpret a display of queue status.

Be aware of how transactions can be routed for different stages in the total processing. If input from IMS A is being processed in IMS C, the processing program can invoke the exit routine to determine whether to send its output to the original input terminal or to another location. Your documentation of the exit routine should show the patterns of alternative message destination. An end user could be expecting output and be unaware that it is being sent to another component.

**Related Reading:** For more information on routing exit routines, see:

- “TM and MSC Message Routing and Control User Exit Routine” on page 247
- *IMS Version 9: Customization Guide*

### Managing Error Messages with DFSCMUX0

The Message Control/Error exit routine (DFSCMUX0) allows you to manage and control messages that are in error on an MSC link or on a message queue. It is activated by an MSC link start, link termination, send error, or receive errors. The Message Control/Error exit routine is called for these situations for APPC/IMS:

- If an LU 6.2 session fails while sending an output message to an LU 6.2 program
- If a send to an LU 6.2 application program is rejected with a Deallocate with Send\_Error message
- When `/DEQUEUE lunametpname` is entered

You can customize the Message Control/Error exit routine to ask IMS to take any of these actions:

- Take the default action: discard the message and proceed with the `/DEQUEUE` command.
- Discard the message in error.
- Discard the message in error and notify the MTO or originating terminal of this error.
- Re-route the message in error to a different local or remote transaction, a local or remote LTERM, or an LU 6.2 application program.

The sample exit routine that is provided in `IMS.ADFSSRC` uses the default action.

**Related Reading:** For more information on the Message Control/Error exit routine, see *IMS Version 9: Customization Guide*.

### How Network Definition Is Affected by Multiple Systems

Each system definition must have all terminals that are connected to it defined using the `TERMINAL` and `NAME` macros. However, if terminals in other systems are capable of sending messages that are destined for the defined system, those terminals are logically part of the network for that system.

Although MSC physical and logical links continue to be predefined through the system definition process, you can dynamically create MSC remote LTERMs during IMS initialization with Extended Terminal Facility (ETO). Although you cannot define your MSC links using ETO, ETO does allow you to associate one or more message queues with an MSC logical link.

**Related Reading:** For more information on creating MSC remote LTERMs with ETO, see Chapter 9, “Administering the Extended Terminal Option,” on page 147.

When a transaction is processed in a remote system, the input LTERM name in the local system is carried over as part of the message. If the processing program uses the alternate PCB to direct a message to another terminal besides the input terminal, those destinations need to be declared as remote, unless directed routing is used. Define the LTERM names for all inputs with `NAME` macros. Position the `NAME` macros in a group after the `MSNAME` macro. You now have a set of LTERMs that collectively can occur in several system definition decks. For example, `TERMA` can be present in the input system, in the intermediate system, and in the processing system.

When planning for the network, keep in mind that message queues for an input system or an intermediate system must allow for the remote transactions being queued. When allocating space for the message queues take into account the

## System Definition for Multiple Systems Coupling

message lengths and their expected loads. In a similar way, you must allow for the presence of these messages in I/O buffers, even when they are not going to be processed in that system.

---

## Verifying Transaction Definitions Across Systems

After you have completed system definitions for several systems that are to be part of a multiple-system network, the transaction codes, LTERM names, and system identification numbers are all identifiable in control blocks.

### Using the Multiple Systems Verification Utility

You can use the IMS Multiple Systems Verification utility offline in order to verify that the names you have used are consistent across system definitions.

**Example:** If you use TRANX as a code in two definitions but TRANXX in a third system, the Multiple Systems Verification utility sends you a message highlighting the single reference to TRANXX.

You can execute the Multiple Systems Verification utility by using the IMSMSV procedure in IMS.PROCLIB.

The Multiple Systems Verification utility also checks to ensure that transaction codes are not defined as local in more than one system.

The Multiple Systems Verification utility uses input control statements that specify the system identification numbers that you want to include in the checking. Its output is in the form of a multisystem path map.

**Restriction:** The Multiple Systems Verification utility cannot detect errors caused by improper use of MSC directed routing.

**Related Reading:** For a description of the output and execution JCL for the Multiple Systems Verification utility, see *IMS Version 9: Utilities Reference: Database and Transaction Manager*.

### Verifying the System Definition Status Online

You can check the consistency of your system definitions or ETO MSC descriptors using the /MSVERIFY command when each of the component systems of your network is operational.

**Recommendation:** Use the /MSVERIFY command during the system test phase, rather than during production. The /MSVERIFY command generates considerable traffic.

The /MSVERIFY command validates that:

- Logical terminals exist for the remote LTERMs defined.
- Transactions are defined and have the same attributes in their remote system as in the local system.
- Logical path definitions are consistent and usable.

**Recommendation:** Define your remote LTERMs using ETO MSC descriptors. Otherwise, the Multiple Systems Verification utility recognizes remote LTERMs, but not the corresponding local LTERM in the target system.

## Verifying Transaction Definitions Across Systems

The /MSVERIFY command verifies consistent definition between the local system and one remote system for each command. Verification begins with local SYSIDs and then proceeds to remote SYSIDs. As each segment of the processing begins, the MTO is notified of the local and remote SYSIDs to be verified. This message, DFS2234I or DFS2236I, also is time-stamped. As the specific local and remote SYSIDs are verified, the MTO receives verification-completed notifications with corresponding time stamps. If a definition or assignment error is discovered, error messages are returned.

During command processing, the local system sends all its own locally defined MSC elements (SYSIDs) to the remote IMS system specified in the /MSVERIFY command. The remote system responds by returning all destinations and their attributes that belong to the local system (as the remote system definition or assignments have them described). The command input system checks local and remote definitions for consistency.

The response list should be checked for completeness using the listing of SYSIDs that are to be verified given in the DFS2234I or DFS2236I IN PROGRESS messages and the correspondence of time stamps in responses.

The local system then sends all MSC elements to the remote system expecting them to be defined in that remote system with corresponding attributes (as the local system has them defined). The remote system performs consistency checks and routes error messages to the command input terminal.

MSC path consistency is only checked for current operational assignments of logical link paths to logical links, and logical links to physical links.

**Recommendation:** Ensure that the MSC definition and assignments are accurate, even when receiving favorable responses (that return no errors). Definition and assignment errors can prevent the return of a command response for some SYSIDs. Regard the absence of a response for a particular SYSID as significant.

Reviewing these error responses from the /MSVERIFY command might help you to avoid these definition and assignment errors:

```
DFS2235I SYSID __ is defined as local in both systems
DFS2241I __ is defined as remote transaction in both systems
DFS2242I __ is not defined as LTERM in both systems
DFS2243I __ is not defined as transaction in both systems
DFS2245I Multisegment transaction flag for __ not consistent
DFS2246I Non-inquiry only flag for __ not consistent
DFS2247I Conversational flag for __ not consistent
DFS2248I Irrecoverable flag for __ not consistent
DFS2249I Fixed length SPA flag for __ is not consistent
DFS2250I The SPA length for __ is not the same
```

The /MSVERIFY command cannot detect errors caused by improper use of MSC directed routing.

---

## Security Considerations for MSC

For those transactions that are processed in another system, perform as much security checking as is required for the primary message. RACF and the Security Maintenance utility (SMU) can both be used to protect IMS resources in an MSC network.

## Security Considerations for Multiple Systems

Signon verification, combined with transaction authorization and password checking, allows you to control the processing at input time. The resource definition to RACF or SMU must declare the transaction name, even when the transaction is not processed in the system where the security tables are built.

Security controls in an MSC network are performed independently in each local and remote IMS. An intermediate IMS in an MSC environment, which is neither local nor remote for a given transaction, does not perform any security checking for that transaction.

SMU password security is verified in the local IMS when a terminal receives input and after execution of the TM and MSC Message Routing and Control User exit routine (DFSMSCE0). SMU terminal security is verified in the local IMS at the time of terminal input and after an application's use of a DL/I CHNG call, if the call is issued in the input system.

When a remote IMS receives a message to process, it verifies security based on the transaction's association with the logical link path. Using link security, you declare transactions in SMU input of the destination system that are authorized for each link path name. This prevents transactions that are sent by unauthorized systems from being processed.

RACF can also provide transaction authorization checking when a destination system receives a message to process. The amount of checking that RACF provides depends on the MSCSEC= parameter in the DFSDCxxx IMS.PROCLIB member and on feedback from the DFSMSCE0 exit routine. The DFSMSCE0 user exit can optionally override or accept the system DFSDCxxx member security, on a message by message basis.

Transactions received in a remote IMS on an MSC link are passed to the transaction authorization module for authorization checking, but because the password is not passed across the link, transaction authorization checking fails if a password is required. Transactions that don't require a password can be accepted.

To allow a transaction to be scheduled in a remote destination IMS, you can authorize its processing with application group name (AGN) security or resource access security (RAS). If you use AGN security, an AGN name must be authorized by a user-written security exit routine, or you can use RACF. The transaction must be declared in SMU input for the processing system as part of the AGN table for the dependent region. If RAS security is used, the transaction must be defined to RACF as authorized for use by the dependent region.

If the RACF security environment is not available in the destination system (as when a /SIGN ON command is entered with RACF), the security environment will be dynamically created to allow the transaction authorization to proceed.

**Related Reading:** For more information on security, see

- Establishing IMS Security, in *IMS Version 9: Administration Guide: System*
- Security Maintenance utility (DFSISMP0), in *IMS Version 9: Utilities Reference: System*



---

### Establishing Operating Procedures for Multiple Systems

Each system in an MSC network is operationally an independent unit. Each system exclusively owns its own communication resources, which are controlled by its own master terminal.

#### Initializing Multisystem Communication

Communication between two IMS systems using non-VTAM connections does not begin until the /RSTART LINK command is issued in each system. When the physical link type is controlled by VTAM, only one side needs to issue the /RSTART LINK command. The normal procedure is for the master terminal operator to issue this command when a system is started up. Communication is allowed only if the characteristics of the specified links are compatible. If a required link is not successfully started, messages wait until the links are reassigned.

The SYSID of each IMS system running in a shared queues group (SQG) can either be cloned across all systems, or not. If the SYSIDs are not cloned, then all IMS systems in the SQG must be initialized so that they are all running at the same time. Once all IMS systems have been initialized, transaction processing can begin, and individual IMS systems can be brought down and later restarted as needed. Initialization allows all IMS systems to exchange MSC SYSIDs and MSNAMES, and creates a SYSID table that contains all of the SYSIDs for that SQG. If the SYSIDs for all IMS systems in a SQG are cloned, then you do not need to perform this initialization.

If a system that has messages queued in it is cold started, these messages are lost. Because the messages that were lost can be from or to terminals and programs in other systems, the impact of a cold start is not limited to the cold-started system.

In a shared-queues environment, IMSs in the IMSplex exchange SYSIDs and MSNAMES at initialization. An IMS then create dynamic MSNAMES based on the MSNAMES other IMSs have and it does not. The dynamic MSNAMES result in paths to all of the IMSs in the IMSplex. The SYSIDs are merged to create a common SYSID routing table. The table is the same in each IMS. Therefore, any local SYSIDs are local in all IMSs and override any remote or undefined SYSIDs. Remote SYSIDs override only undefined SYSIDs.

#### Terminating Multisystem Communication

A /PSTOP LINK command from either of two linked systems terminates transmission on the specified link. When transmission is terminated on one side, its partner in the other system terminates its own transmission and notifies the master terminal operator.

The command forms shown in Table 14 on page 228 are used for physical link termination between partner MSC systems.

## Establishing Operating Procedures for Multiple Systems

Table 14. Commands to Terminate Physical Links

Command	Keyword	MSC Use/Effect
/PSTOP	LINK PURGE	<p>Transmissions associated with the logical link between two partner systems are halted, but queuing for the remote resources continues. Broadcast messages that would use the link are queued but not sent.</p> <p>The logical link is stopped in the partner system and its MTO is notified by message DFS2161.</p> <p>This command applies to CTC link type only, and forces a /PSTOP condition even if the other system fails while CTC I/O is in progress.</p>
/IDLE	LINK NOSHUT	<p>Forces termination of all transmissions on a physical link associated with the named logical link. Use only after shutdown checkpoint.</p> <p>This command applies to SDLC link type only, and forces the /IDLE condition without a checkpoint shutdown.</p>

## IMS Commands That Affect MSC Operation

These topics contain information about the use of IMS commands that have a particular effect relative to the use of MSC facilities.

**Related Reading:** For the definition and format of these commands, see *IMS Version 9: Command Reference*.

### Logical Link Assignments

Initial logical link assignments (logical link to physical link) are made during IMS system definition. Use the /MSASSIGN command to dynamically make or change a logical link assignment. Use this approach primarily for unscheduled reassignments resulting from failing physical connections or systems.

Because a logical link must *always* communicate with its partner, the master terminal operators of the two systems must coordinate their assignments to a corresponding physical link. Any type of physical link can be replaced by any other type of physical link.

The /MSASSIGN command is used to change the logical assignments of MSC system resources. All such changes remain in effect until they are changed by another /MSASSIGN command or until IMS is cold started. The relationship of MSC resources is changed only in the local system.

You can change these logical link relationships using the /MSASSIGN command:

1. Logical link to physical link
2. Remote SYSID to logical link
3. Logical link path to logical link

The /MSASSIGN command can also change a remote program to local, or it can change a local program to remote and assign a logical path.

When you use the /MSASSIGN command:

- Operating logical or physical links must be assigned one-to-one, except for a VTAM-type link with parallel sessions in effect. In this case, multiple logical links can be assigned to one physical link.
- Logical links must be halted by /PSTOP and must be idle before being reassigned.
- A destination SYSID cannot be reassigned to a logical link unless its currently assigned logical link is idle after a /PSTOP.
- MSC communication can occur only when logical links in two IMS systems share the same partner identification and have assignment to an operating communications facility between the systems.
- The /MSASSIGN command does not determine whether the requested assignment is reasonable or results in a valid configuration for MSC communication. This is only done by communication with appropriate remote systems, you can accomplish this using the /MSVERIFY command after making assignment changes.

### Restarting a Logical Link

If a restart is pending on a logical link because of a physical link failure, both systems should use this procedure to reestablish communication through an alternative physical link:

1. Reassign the logical link to the alternate physical link.
2. Use the /RSTART LINK command to start the logical link.

If the link uses VTAM, the /PSTOP MSPLINK command must be executed before assignment either to or from the VTAM MSPLINK name.

### Commands That Help Control Resources

You can review the commands shown in Table 15 to assess their effects in your MSC environment.

If an MSC error occurs when the MSC trace is not operational, check the log for X'67' records, because some error information is logged even when the link trace is not set on.

You can use the /TRACE command when link problems are suspected:

```
/TRA SET ON LINK X LEVEL 3 MODULE DDM
```

*Table 15. MSC Environment Commands*

Command	MSC Use and Effect
/ASSIGN	Change transaction priorities.
/CHANGE	Change link mode table and session restart.
/DELETE	Remove password security.
/PSTOP	Queue for remote processing, but do not send.
/PURGE	Reject subsequent primary requests for remote processing. Accept secondary or continued conversational requests. Continue sending those requests that are allowed to queue.

## IMS Commands That Affect MSC Operation

Table 15. MSC Environment Commands (continued)

Command	MSC Use and Effect
/STOP	If remote program or terminal stopped in input system: Return DFS065 to input terminal if a primary request. Queue but do not send secondary requests. If local program or terminal accessed by remote MSC systems: Queue secondary requests. Return message DFS065 to input terminal in input system for primary requests. Message DFS065 identifies, by SYSID, the MSC processing system that rejected the message. Message is logged, but canceled.
/START	Reset previous /START and /PSTOP effects.
/BROADCAST	Use of the LTERM keyword value ALL sends the broadcast message to all terminals of the local system only. No general broadcast capability exists for remote MSC terminals. Their LTERMs must be defined in the broadcasting system and specified in the command. Broadcasts to MTOs of remote MSC systems are possible even when the MTO terminals are not defined in the broadcasting system; use the keyword MASTER. The system must have defined the SYSIDs of such remote systems by MSNAME macros.
/TRACE	Using the LINK keyword, you can invoke a trace of MSC operation. Trace data is recorded within type X'67' records on the IMS system log.

## Using the /DISPLAY Command

The IMS /DISPLAY commands show available information that helps you manage a Multiple Systems Coupling environment. These facilities operate only within the domain of the local system, however, and do not provide information that is available only from remote systems. Table 16 summarizes the information that is available to the MTO with the /DISPLAY command.

Table 16. MSC Information from the /DISPLAY Command

Command	Keyword	MSC Use/Effect
/DISPLAY	ASSIGNMENT	Display current assignment of logical link path (MSNAME) to logical link, and logical link to physical link
	LINK	Logical link (#)
		Physical link (MSPLINK name)
		Local and remote SYSID's by MSNAME
		Resynchronization for SDLC link type (forced or not)
	MSNAME	Same as link display
/DISPLAY	MSPLINK	Logical link (#)
		Physical link (MSPLINK name)
		Physical link type (MTM, VTAM, CTC)
		Physical link address
		Maximum parallel session number for SDLC link type
	SYSID	Same as link display

*Table 16. MSC Information from the /DISPLAY Command (continued)*

Command	Keyword	MSC Use/Effect
/DISPLAY	LINK	Logical link (#) Partner ID Number of messages received, sent, enqueued, dequeued, currently queued for link, link status mode table names, and ASR status
/DISPLAY	MSNAME	Logical link path Total messages dequeued for MSNAME Messages currently queued for MSNAME

### Logical Link Path Control

Several commands are used to control logical link paths. Logical link paths are defined by SYSID pairs that identify sending and destination systems. Logical link paths are named by the MSNAME macro. The logical link path is the lowest level of control across an MSC environment, because it is the lowest level that is necessarily defined in intermediate MSC systems. Table 17 summarizes the commands used for link control.

*Table 17. Commands Used to Control MSC Link Paths*

Command	Keyword	MSC Use/Effect
/START	MSNAME	Start a previously stopped MSNAME.
/STOP	MSNAME	Stop the sending and receiving of primary request messages associated with the logical link path.  When stopped by an input system, primary requests for remote programs or terminals associated with the stopped logical link path are canceled, and message DFS065 is returned to the input terminal. Conversations in progress are allowed to continue.  When stopped by a destination system, messages received from other systems over a stopped logical link path cause a logical link path to be stopped in the sending system (input or intermediate), and MTOs of the sending and receiving systems to be notified by messages DFS2140 and DFS2142, respectively. The message remains queued in the sending system until the logical link is subsequently started in both systems.
/PURGE	MSNAME	Queuing of primary requests for all remote terminals and programs represented by the MSNAME is halted. Continued conversations and secondary requests are handled. Primary requests entered through an input terminal receive DFS065. Requests from other systems that require use of the logical link path for a response are not accepted but remain queued in the sending system. See /STOP MSNAME.

### Recovery Considerations

Each system in the MSC network uses the full recovery capabilities of IMS. These capabilities assure that messages are not lost or duplicated within the single system, as long as no cold start is performed and no log records are lost. VTAM provides message integrity for SDLC in each IMS system link, in addition to the MSC control functions.

#### Message Recovery

MSC assures that messages are not lost or duplicated across a multisystem link, as long as no system in the configuration is cold started and no log records are lost. This is accomplished by logging information about a transmission in both the sending and receiving systems. This information is restored during restart and exchanged between the systems after the link is started. The sending system can then dequeue a message that was received by the receiving system but for which the acknowledgment was lost because of a link or system failure. The sending system can also resend a message that was sent but not enqueued by the receiving system because of a failure in the receiving system. If a system in the MSC network fails to recover, the messages for which it has recovery responsibility are lost.

Because IMS provides commands to dynamically change link assignments, an inoperable processor can be backed up by an alternate processor. The IMS system that resides in the inoperable processor can be executed in the alternate processor after all involved links are properly reassigned by the master terminal operators.

#### Stopped Transactions

If a destination transaction code is stopped for queuing, the action taken by the destination system varies based on the type of request:

- For a primary request that is not conversational or that starts a conversation, IMS sends an error message to the input terminal and cancels the message.
- For a primary request that continues a conversation or a secondary request, IMS queues the message. If the request is the first one received for that stopped transaction, IMS also sends a message to the master terminal at that transaction's local system.

#### Application Program Abnormal Termination

When an application program abnormally terminates, and the abnormal termination is not the result of a deadlock situation, a DFS554A message is sent to the master terminal of the system in which the abnormal termination occurred. If the input message is still available, an error message (DFS555I) that includes the first portion of the input message is sent to the input terminal. When the error message to the input terminal is sent, the DFS554A message includes the logical terminal name of the input terminal.

#### Dequeuing Messages, Responses, and Transactions

You can use the /DEQUEUE command with the PURGE or PURGE1 keyword to dequeue messages, responses, and transactions that are in error for a specific MSC link. When you enter the /DEQUEUE MSNAME PURGE command, the Message Control/Error exit routine (DFSCMUX0) is called before the command executes. The exit routine protects you from inadvertently entering the command in error and potentially destroying a message, response, or transaction by dequeuing it before it reaches its destination. The exit routine can suppress the dequeue of a message.

The system programmer must be aware of each of:

- The existence of the /DEQUEUE command, and the consequences of using it
- The interaction of the /DEQUEUE command with the Message Control/Error exit routine

The MTO should be aware of each of these facts:

- Your installation policy for using the /DEQUEUE command
- The fact that any messages that are dequeued are destroyed
- The /DEQUEUE command should be reserved for emergency use only, or as dictated by your site

### **Recommendations:**

- Only authorize the MTO to issue the /DEQUEUE command.
- Establish installation-specific standards for using the /DEQUEUE command. Be sure to identify in advance and validate the scenarios where the MTO should use this command. Consider the /DEQUEUE command when coding the Message Control/Error exit routine.

### **Related Reading:**

- For more information on the /DEQUEUE command with the PURGE keywords, see *IMS Version 9: Command Reference*.
- For more information on coding the Message Control/Error exit routine, see *IMS Version 9: Customization Guide*.

---

## Monitoring and Tuning Multiple Systems

Plan to obtain both statistical and performance data for IMS online systems that are part of a MSC network. You can use the same monitoring tools that are used for generating performance data for single IMS systems:

- You can execute the IMS Monitor in several systems concurrently. You obtain IMS Monitor reports for each individual IMS system and coordinate your processing analysis.
- The Statistical Analysis utility produces summaries of transaction traffic for each individual system. Again, you combine the statistics for a composite picture.
- The IMS Transaction Analysis utility enables you to trace transactions across multiple systems and examine the traffic using the various active physical links.

## Coordinating Performance Information

If possible, expand your MSC network by increasing the number of SYSIDs (up to 2036) and the number of physical and logical links (up to 676). By expanding the MSC network, you can:

- Access an IMS subsystem from many other IMS subsystems
- Route transactions
- Distribute transaction processing
- Increase network throughput
- Grow beyond the capacity of one IMS system
- Respond to capacity constraints or response-time constraints

The IMS system log for each system participating in MSC contains only the record of events that take place in that system. However, logging is performed to record traffic on the links. Add the SYSIDs of all coupled systems to the system log

## Monitoring and Tuning Multiple Systems

documentation that records the checkpoint intervals. This helps to interpret reports, because you are aware of transactions that might be present in message queues but are not processed, and you can expect additional transaction loads from remote sources.

Your analysis procedures should include ways of isolating the processing that is triggered by transactions originating from another system. Considerations for tuning buffers for the asynchronous communication processing should include a criterion that no exceptional conditions resulting from intersystem traffic exist.

To satisfy the need for monitoring with typical activity that includes cross-system processing, coordinate your scheduling of the DC Monitor and other traces between master terminal operators. The span of the monitoring does not need to be exactly the same, but if it is widely different, the averaging of report summaries might make it more difficult to interpret the effect of the processing that is triggered by cross-system messages.

### Interpreting IMS Monitor MSC Reports

The IMS Monitor Report Print Program includes three reports that highlight message events caused by system coupling:

- MSC Traffic Report, which shows, for the monitor interval, the counts of messages using the various link paths.
- MSC Summaries, which shows summaries of the traffic queues for each input transaction name, each destination name, each link number, and each destination system.
- MSC Queuing Summary Report, which is generated when intersystem messages are queued on the local system before the messages are sent to the destination system. The local system must be an intermediate system. This report shows:
  - Maximum time messages spend in queues
  - Average time messages spend in queues
  - Maximum queue lengths
  - Total number of messages queued for all links the local system participates in

All three reports can have entries in the Distribution Appendix, so that you can examine the frequency distributions of the traffic if you suspect unusual transmission patterns. The Distribution Appendix displays multiple occurrences of an event across a range of values relevant to the event, such as wait times. For example, in the case of wait times, the Distribution Appendix allows you to easily see how often a given event occurs with a specific wait time and what the distribution of the event is across a range of wait times.

#### **Related Reading:**

- For more information on the IMS Monitor Report Print Program, see *IMS Version 9: Utilities Reference: System*.
- For more information on the Distribution Appendix, see both the *IMS Version 9: Utilities Reference: System* and the *IMS Version 9: Utilities Reference: Database and Transaction Manager*.

### Determining Cross-System Queuing

The MSC Traffic report indicates the individual queue loads for all traffic between partner systems for which the monitored system is the local system. The report lists all the unique system identification numbers (SYSIDs) that are defined for



communications for that local system. It then summarizes the total number of messages queued and dequeued for each combination of these variables:

- Input name (terminal or program that was a message source)
- Destination name (terminal or program)
- Input system (SYSID)
- Destination system (SYSID)
- Link number
- Link type (MTM, CTC, or VTAM)

Figure 35 is a sample MSC Traffic report. If a message originates in the local system, its presence is accounted for in the dequeue counts only. Messages with local destinations appear only in the enqueue count.

```

IMS Monitor  **MSC TRAFFIC REPORT**  TRACE START 1993 209 13:30:32  TRACE STOP 1993 209 14:03:49  PAGE 0016
LOCAL SID VALUES = 18, 19, 21, 22, 23, 24, 25, 26, 42

```

INPUT NAME	DESTIN. NAME	INPUT SID	DEST. SID	LINK NO.	LINK TYPE	ENQUEUE COUNT	DEQUEUE COUNT	
T3270V	T3270V	11	11	1	VTAM	0	22	
		13	13	2	VTAM	0	1	
		12	12	1	VTAM	0	2	
		21	21	1	VTAM	4	0	
		TRAN21P0	11	21	1	VTAM	2	0
		CONV21V0	11	21	1	VTAM	22	0
		ITRL	11	11	1	VTAM	0	5
		CONV12V0	11	11	1	VTAM	0	2
			21	11	1	VTAM	0	3
		CONV12V1	12	12	1	VTAM	0	1
		CONV21V1	12	22	1	VTAM	3	0
		LTERM10V	11	11	1	VTAM	0	2
			21	11	1	VTAM	0	4
		CONV21C0	13	23	2	VTAM	1	0
		UTR10U6	14	24	3	VTAM	4	0
		FTRL	11	21	1	VTAM	4	0
	TOTAL TRAFFIC						40	42

Figure 35. MSC Traffic Report

### Assessing the Effect of Link Loading

The MSC Summaries report provides a picture of the enqueue and dequeue activity for messages that are handled by the local system but that are also a part of the MSC traffic.

The report format is illustrated in Figure 36 on page 236.

The first set of queuing counts shows how many transactions of each type were entered in the monitor interval and how many were subsequently dequeued.

The second set of counts summarizes the total traffic for each destination name. You can distinguish the primary transactions and responses by the resource names and examine the relative servicing of the link transmissions using the difference between the enqueue and dequeue counts.

The third set of counts lists the active links by link number, and you can tell if buildup on the link exists by the difference in the enqueue and dequeue counts.

The fourth set of counts records the traffic that is going to other systems by any link path. By looking at the difference in enqueue and dequeue counts, you can

## Monitoring and Tuning Multiple Systems

determine whether the overall pattern of link priorities to one or more systems is causing buildup of cross-system traffic.

```

IMS Monitor   ****MSC SUMMARIES****   TRACE START 1993 13:30:32   TRACE STOP 1993 14:03:49   PAGE 0015

<--SUMMARY OF INPUT NAME--><--SUMMARY BY DEST. NAME--><--SUMMARY BY RELATIVE LINK--><--SUMMARY BY DEST. SYS. ID-->
INPUT  ENQUEUE  DEQUEUE  DESTIN.  ENQUEUE  DEQUEUE  LINK  ENQUEUE  DEQUEUE  DEST.  ENQUEUE  DEQUEUE
NAME   COUNT     COUNT   NAME     COUNT    COUNT   NO.   COUNT    COUNT   SID    COUNT    COUNT

*NONE*  0         1       LINK21B1  0        1       1     12       14       11
      13         14
T3270L1 25        25     T327011  13       13      4     13       12       31     12      12
      CONV31B0  7        7
      TRAN31B0  5        5
  
```

Figure 36. MSC Summaries Report

## Assessing Link Queuing Times

The MSC Queuing Summary report provides information about intersystem message traffic only. You can use the sample of traffic recorded in the IMS Monitor interval in order to examine the maximum and average time messages spend in queues waiting to be sent on active links. You can detect whether the link priorities are causing undue delay of primary messages through the intermediate system, or whether a buildup of responses exists. The report shows the logical link paths for this system, which is an intermediate system. Each incoming link number shows the number of messages that are queued before transmission on their specified outward-bound link number. The maximum queue count is given, as well as the maximum and average time on the intermediate system queues.

The report is illustrated in Figure 37.

```

IMS Monitor   ****MSC QUEUING SUMMARY****   TRACE START 1993 13:30:32   TRACE STOP
1993 14:03:49   PAGE 0016

ENQUEUE.....  DEQUEUE.....  MESSAGES  MAX. 0  MAX. 0  MEAN  DIST.
LINK NO. TYPE  LINK NO. TYPE  MESSAGE   LENGTH  0 TIME  0 TIME  NUMBER

   4  VTAM      1  VTAM      13         1      287011  101902  5
   1  VTAM      4  VTAM      12         1      282596  73531  8
   3  VTAM      3  VTAM      26         1      287012  73641  7

TOTALS.....                51                                83021
  
```

Figure 37. MSC Queuing Summary Report

## Extracting Multiple-System Transaction Statistics

You can use the Log Transaction Analysis utility to obtain counts of the message traffic both in local systems and between systems. The transmissions over the different types of physical links can also be examined. (The activity is summarized for each step of the logical link paths.) You must provide IMS system log input that reflects all partner system activity, that is, sets of system logs for each MSC system. To coordinate the sets of individual system logs, use the Log Merge utility. As many as nine separate system logs can be merged, each log being the output of a uniquely identified IMS system with MSC installed.

## Controlling the Log Merge

To control the log output, you need to:

- Choose the required systems that participate in the logical link paths you want to examine.
- Coordinate the series of input logs for each system so that they cover a similar time span.
- Specify a start and stop time for the Log Merge utility control statements if you want to sample the cross-system processing for a particular interval.

You can give both start date (Julian) and time of day, or just time of day. It is the first system log (specified by the LOG01 DD statement) to which these times apply. Other log activity is collected if it falls between the initial and final events that are present on the first log.

- Specify MSG to select log records that are suitable for the transaction analysis step. (ALL records is the default, but this means the DL/I activity for several systems is included in the utility input, and this can cause extended processing time.)

### Interpreting the Transaction Analysis Report

Using the Log Analysis report produced by the IMS Transaction Analysis utility, you can obtain these statistics for individual transactions that are processed in any system:

- The total response time
- The time on input and output queues
- The processing time

**Related Reading:** For an illustration of this report, see *IMS Version 9: Utilities Reference: Database and Transaction Manager*. It also includes definitions for the format of the detailed report records produced by the IMS Transaction Analysis utility and a list of processing type codes. The absence of times for a message GU call or MPP termination in the report lines indicates an input source or intermediate system report line.

The processing type field is an important one for the interpretation of the detailed report lines. The S code indicates that this line shows a send or receive event for the transaction. You can trace the progress of a cross-system conversation using the codes C, D, P, X, and Y.

The report headings include a column headed ID after the column for the GU to the message queue time. The number shown in a report line under the ID heading matches the sequence in which log input is fed to the Log Merge utility. The field corresponds to starting position 102, the 3-digit field named SYSTEM ID, in the detailed report records.

You can use the sort step to reorder the report records in any order you want, for example, by system ID within transaction code. The default order is the input sequence.

---

### MSC and IMSplex with Shared Queues: Migration and Coexistence

This topic discusses the coexistence of a Multiple Systems Coupling (MSC) network with an IMSplex with shared queues. MSC and IMSplex coexistence can be temporary, such as when migrating from an MSC network to an IMSplex configuration, or permanent, such as when an MSC link connects an IMSplex to an IMS system outside of the IMSplex.

A primary concern when an MSC network and an IMSplex coexist is the proper routing and processing of your transaction messages across both the MSC and IMSplex environments, because each environment uses a different routing method.

Generally, MSC networks route transactions to specific IMS systems using SYSIDs, while IMSplexes with shared queues route transactions by making them available on the shared queue to any IMS system that registers an interest in the

## MSC and IMSplex with Shared Queues

transactions. When an MSC network and an IMSplex with shared queues coexist, both of these methods of routing can apply to transactions.

The following topics provide additional information:

- “Message Routing Across MSC and IMSplex Environments”
- “Migrating From an MSC Network to an IMSplex Network” on page 240
- “Managing Remote Transactions for APPC and OTMA When MSC and IMSplexes Coexist” on page 245
- “Avoiding Pseudoabend U0830” on page 247

## Message Routing Across MSC and IMSplex Environments

MSC uses local and remote SYSIDs and destination names to route messages across links between local, intermediate, and remote IMS systems in an MSC network. IMSplexes with shared queues use destination name registration, IMSIDs, a shared queue, and the registered interest of IMS systems to route messages between front-end and back-end IMS systems in an IMSplex. When an IMSplex and an MSC network coexist, both methods of routing can be used.

In MSC networks and IMSplexes with shared queues, IMS stores the SYSID, destination name, and IMSID value in the message prefix when IMS builds the message and places it on a local or shared queue. The SYSID, destination name, or IMSID stored in the message prefix must match the SYSID, destination name, or IMSID of an IMS system in either the IMSplex or the MSC network. If they do not match, any messages on the shared queue or in flight in the MSC network will trigger a routing error, such as a pseudoabend U0830, when an IMS system attempts to process the message. This condition can occur, for example, if the IMS system that owns the SYSID, destination name, or IMSID is down or has changed its value.

### How Messages Are Routed in an MSC Network

In an MSC network, IMS uses remote transactions, remote logical terminal (LTERM) names, and SYSIDs to route the messages through the MSC network. Remote transactions are defined by specifying remote and local SYSIDs in the TRANSACT macro. Remote LTERMs are defined in NAME macros immediately following an MSNAME macro. The remote and local SYSIDs in the MSNAME macro are then associated with the remote LTERM. IMS stores the remote transaction codes, LTERM names, and SYSIDs in the message prefix of each message routed through the MSC network. In this context, the transaction codes and LTERM names are referred to as destination names.

MSNAME labels can also be used as intermediate destination names, when messages must pass through an intermediate IMS system prior to reaching the IMS system that contains the true destination name. In this case, the MSNAME label is also stored in the message prefix.

### Related Reading:

- For additional information on using SYSIDs and destination names to route messages in an MSC network, see “Routing Messages with the Destination Name and SYSIDs” on page 206.
- For information on completing the MSNAME, NAME, and TRANSACT macros, see:
  - “System Definition for Multiple Systems Coupling” on page 217
  - *IMS Version 9: Installation Volume 2: System Definition and Tailoring*

### How Messages Are Routed in an IMSplex with Shared Queues

In an IMSplex with shared queues, IMS uses origin names and destination names registered with a coupling facility to route messages between front end and back end IMS systems.

Origin and destination names can be logical terminal names, transaction codes, or APPC or OTMA client names. You define static origin and destination names during system definition. You define in descriptor libraries or user exits the origin and destination names that are dynamic LTERMs, ETO terminals, or dynamic transactions. Origin and destination names for APPC or OTMA clients are sent, in the form of an 8-byte token, to IMS when an APPC or OTMA client allocates a conversation.

IMS registers transactions when they are started and a dependent region or an MSC link is started and ready to process messages. IMS registers LTERM names with the coupling facility when they are started or when they sign on and are ready to process messages. IMS registers APPC and OTMA tokens when an APPC or OTMA conversation is allocated. IMS deregisters APPC and OTMA tokens when the APPC or OTMA conversation is deallocated.

Messages carry these origin names and destination names in the message prefix. When an empty shared queue on a coupling facility receives a message from a front-end IMS system for a registered destination name, the coupling facility notifies all interested IMS systems that there are messages to process.

### Message Routing When an IMSplex and MSC Network Coexist

When an IMSplex with shared queues and an MSC network coexist, IMS routes messages between front-end, back-end, and remote IMS systems using origin and destination names, MSC SYSIDs, and IMSIDs.

IMS uses the coupling facility and the shared queues to route messages within the IMSplex. IMS uses MSC links only to route messages to IMS systems outside of the IMSplex. Any MSC link definitions that exist between IMS systems in the IMSplex are not used.

Transactions defined for routing in an MSC network can also be routed in an IMSplex with shared queues but the method used for routing is that of the IMSplex and not MSC; however, the IMSplex does recognize the MSC SYSID attributes of the transaction. The recognition of the SYSIDs by the IMSplex allows the IMSplex to handle remote transaction in a manner similar to the MSC network. This also has implications for local processing affinity, which is discussed in "Processing Affinities in an IMSplex-MSC Coexistent Configuration."

Transactions not specifically defined for routing in an MSC network cannot be routed outside of the IMSplex using an MSC link.

### Processing Affinities in an IMSplex

If a message must process on a specific IMS system in the IMSplex, IMS assigns the message affinity to that IMS system by appending the IMSID of the IMS system to the destination name. Then, only that IMS can process it.

### Processing Affinities in an IMSplex-MSC Coexistent Configuration

In an MSC network, remote transactions bypass any local affinity the transactions might have to the IMS system that receives them as input. In an IMSplex, remote

## MSC and IMSplex with Shared Queues

transactions also cause local affinity to be bypassed. Otherwise, the rules that govern processing affinities in an IMSplex remain unchanged.

**Related Reading:** For more information on how APPC and OTMA messages are processed when IMSplexes coexist with MSC networks, see “Managing Remote Transactions for APPC and OTMA When MSC and IMSplexes Coexist” on page 245.

## Migrating From an MSC Network to an IMSplex Network

When migrating or converting an existing MSC network to an IMSplex with shared queues, you need to retain the MSNAME definitions in your IMS systems for as long as you have transaction messages that use those definitions on the shared queues. You also need to retain any MSC link definitions to IMS systems outside the IMSplex. Once you have finished testing the IMSplex and are sure you will not need to return any IMS systems in the IMSplex to an MSC-only network, you can remove any MSC link definitions between IMSplex member systems.

In an IMSplex, if one IMS system is MSC capable, then all the IMS systems in the IMSplex must be MSC capable. To enable an IMS system for MSC, define an MSC link for the IMS system during system definition. This MSC link definition does not need to be functional.

### MSC Link Definitions in an IMSplex

During the migration process from an MSC network to an IMSplex, you can retain your MSC link definitions for as long as you have a need for them. This allows you to test the IMSplex with shared queues environment and then revert to the MSC network to make adjustments.

After you have established the IMSplex with shared queues, you should not add new MSC links between the IMS systems in the IMSplex. If you attempt to start an MSC link between two IMS systems within the same IMSplex with shared queues, IMS issues message DFS2149 and aborts the link startup.

### Sharing MSNAME Definitions and SYSIDs in an IMSplex

In an IMSplex with shared queues, when you start an IMS system that includes MSNAME statements, the IMSplex shares the MSNAME statements and the local SYSIDs of the joining IMS system with the other IMS systems already in the IMSplex.

For each MSNAME statement in the joining IMS system, the IMSplex creates a duplicate dynamic MSNAME statement in each of the other IMS systems in the IMSplex, unless one already exists.

For each local SYSID owned by the joining IMS system, the IMSplex adds a duplicate local SYSID to the SYSID table in each of the other IMS systems in the IMSplex. This effectively makes the SYSID of the joining IMS system local to the IMSplex as a whole. The IMSplex updates the SYSID table of each IMS system in the IMSplex whenever an IMS system that has an MSNAME statement joins or rejoins the IMSplex.

The generation of dynamic MSNAME statements and the sharing of local SYSIDs throughout the IMSplex allow the IMSplex to function as a single IMS system on the MSC network. It also allows transactions defined to run in an MSC network to take advantage of the distributed processing of the IMSplex with shared queues.

To illustrate dynamic MSNAMEs and shared SYSIDs, Figure 38 shows a simple MSC network prior to introducing an IMSplex with share queues. Figure 39 on page 242 then shows the same MSC network after an IMSplex with shared queues has been created between two of the IMS systems.

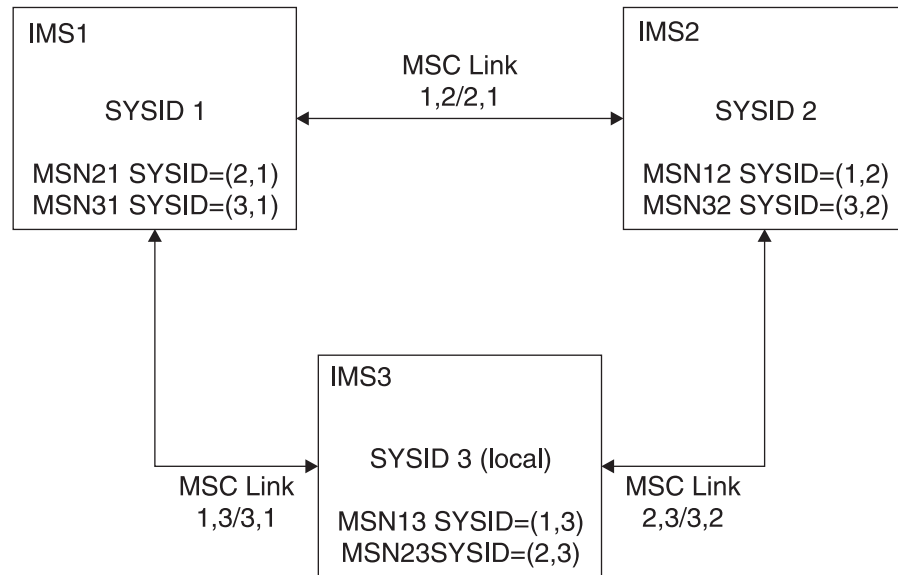

Figure 38. MSC network without an IMSplex

In Figure 38, IMS1, IMS2, and IMS3 are each members of the MSC network. Each of their local SYSIDs are unique and their MSNAME statements only define the links that are defined locally in each IMS system.

## MSC and IMSplex with Shared Queues

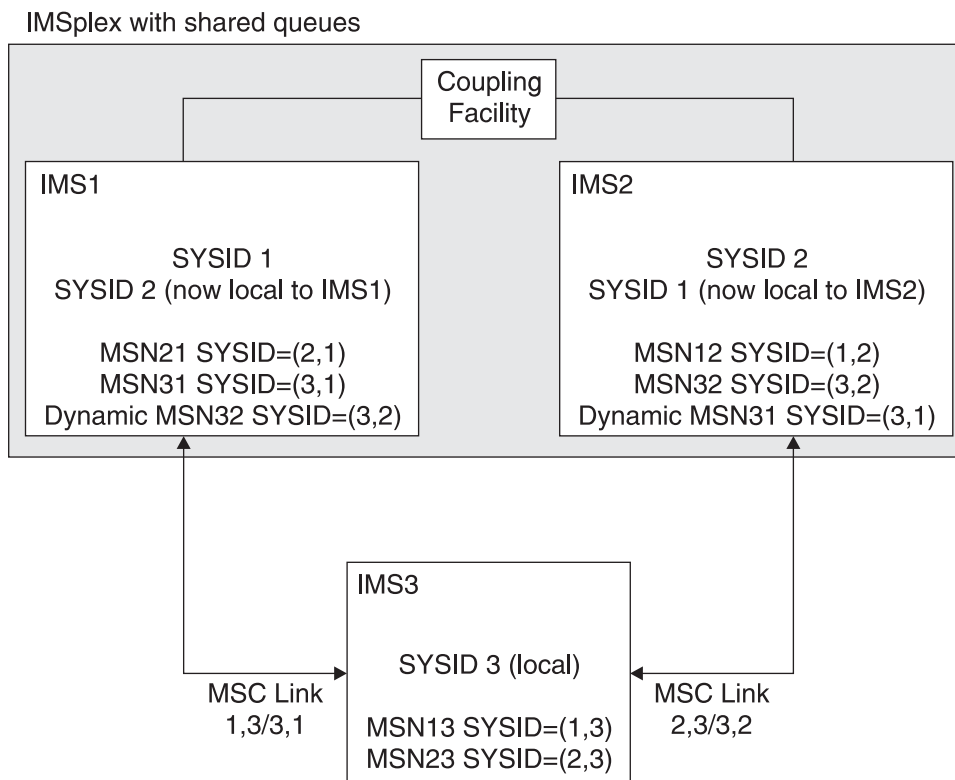

Figure 39. MSC network coexisting with an IMSplex with shared queues

In Figure 39, IMS1 and IMS2 are now part of an IMSplex with shared queues. Because of this, SYSID 1 becomes local to IMS2 and SYSID 2 becomes local to IMS1. Similarly, dynamic MSNAME MSN31 appears in IMS2, and dynamic MSNAME MSN32 appears in IMS1. IMS1 and IMS2 also remain connected to the MSC network and IMS3, although IMS1 and IMS2 now function as a single IMS system, or node, within the MSC network.

Table 18 represents the SYSID tables of the IMS systems shown in Figure 38 on page 241 prior to introducing the IMSplex:

Table 18. SYSID ownership in an MSC network without an IMSplex

SYSID	IMS1	IMS2	IMS3
1	Local	RMT/MSN12	RMT/MSN13
2	RMT/MSN21	Local	RMT/MSN23
3	RMT/MSN31	RMT/MSN32	Local

Table 19 represents the resulting SYSID tables in each IMS after the IMSplex is introduced into the MSC network, as shown in Figure 39:

Table 19. SYSID ownership in an MSC network that coexists with an IMSplex

SYSID	IMS1	IMS2	IMS3
1	Local	Local	RMT/MSN13
2	Local	Local	RMT/MSN23
3	RMT/MSN31 Dynamic MSN32	RMT/MSN32 Dynamic MSN31	Local



When an IMS system leaves the IMSplex, the IMSplex does not change the SYSID tables or delete any dynamic MSNAME statements in the remaining IMS systems. This ensures that if there are any messages on the shared queues that use the MSNAME definitions of the departed IMS, the IMSplex can still process them. When an IMS system rejoins the IMSplex, the IMSplex always exchanges MSNAME statements again and revalidates the rejoining SYSID on all SYSID tables in the IMSplex.

Whenever an IMS system successfully joins or leaves an IMSplex with shared queues, the IMSplex issues message DFS0778I to the master terminal of each IMS system in the IMSplex.

### MSNAME Duplication in an IMSplex with Shared Queues

For each IMS system that participates in both an MSC network and a shared queues group, MSNAMEs and their associated remote and local SYSIDs are exchanged with the other IMS systems in the shared queues group when the IMS is initialized. Dynamic MSNAMEs are created in each IMS system for the MSNAMEs that were defined on the other IMS systems in the shared queues group.

A common MSC SYSID routing table is built in each IMS system from the remote and local SYSID values that are defined in each MSNAME. SYSIDs that are local in each IMS system are also made local to the other IMS systems in the shared queues group. The same local SYSIDs on all IMS systems in the shared queues group allow any message received from an IMS system outside the shared queues group through an MSC link to be routed and processed by any IMS system in the shared queues group.

Duplicate MSNAMEs in IMS systems in a shared queues group must have the same remote SYSID because MSNAMEs and remote SYSIDs are synonymous. The same MSNAMEs must relate to the same remote SYSIDs. Different local SYSIDs for the same MSNAME are allowed.

If the same MSNAME is defined with different remote SYSIDs in two IMS systems, the MSNAME is ignored when MSNAMEs are exchanged within the shared queues group. Dynamic MSNAMEs are not created in the IMS systems with the same MSNAME and each IMS retains its own version of the MSNAME.

Each of these two examples show valid combinations of MSNAMEs that have the same name in a shared queues group:

- A valid MSNAME pair:
  - (On IMSA) MSN12345 MSNAME SYSID=(1,2)
  - (On IMSB) MSN12345 MSNAME SYSID=(1,2)
- Also a valid MSNAME pair:
  - (On IMSA) MSN12345 MSNAME SYSID=(1,2)
  - (On IMSB) MSN12345 MSNAME SYSID=(1,3)

This is an example of an invalid combination of MSNAMEs that have the same name in a shared queues group:

- (On IMSA) MSN12345 MSNAME SYSID=(1,2)
- (On IMSB) MSN12345 MSNAME SYSID=(2,1)

**Related Reading:** For information on the enforcement of resource type consistency for MSNAMEs in an IMSplex, see “TM Resources: MSNAMEs” on page 132.

### Deleting MSNAME Definitions From the SYSID Tables in an IMSplex

To remove a SYSID or an MSNAME statement from the IMSplex, you must first remove it from the IMS system that owns it and then cold start the IMS system back into the IMSplex. After you have removed the SYSID or MSNAME statement from its original owning IMS system, warm or cold start each of the other IMS systems in the IMSplex to rebuild their SYSID tables.

### Removing MSPLINK and MSLINK Definitions When an MSC to IMSplex Migration Is Complete

After the migration of an MSC network to an IMSplex with shared queues is complete and you are sure you will not return any IMS systems to their MSC-only state, you should remove the MSPLINK and MSLINK definitions for the MSC links that you will no longer use.

**Note:** You must retain at least one MSC link definition in each IMS system in the IMSplex to maintain MSC enablement throughout the IMSplex. This link can be a functioning MSC link to an IMS system outside of the IMSplex or a non-functioning link defined only to attach MSNAME statements to and to ensure MSC enablement.

### Managing SYSIDs When MSC and IMSplexes Coexist

Local SYSIDs must be unique in an MSC network. Local SYSIDs are not required to be unique within an IMSplex; however, local SYSIDs owned by IMSplex members linked to an MSC network outside of the IMSplex must be unique in that MSC network. Also, if multiple members of an IMSplex link to the same IMS system outside of the IMSplex, each IMSplex member must use a local SYSID that is unique to that outside IMS system.

You cannot use the same remote SYSID to point to different IMS systems in an MSC network.

### Cloning MSC SYSIDs in an IMSplex

Even though the IMSplex adds every local SYSID in the IMSplex to each SYSID table in the IMSplex, you should clone all local SYSIDs within each IMS system in the IMSplex when removing the intra-IMSplex MSC links. To clone a local SYSID, clone an MSNAME statement that contains it.

Cloning local SYSIDs ensures that the IMSplex can route and process messages on a shared queue even if the IMS system that owns the SYSID is not available and the SYSID is not included in the SYSID tables in the IMSplex. MSC SYSIDs are not stored in the coupling facility within the IMSplex. If an IMS system cannot recognize the SYSID of a message on the shared queue as local when processing application program messages, the IMSplex issues pseudoabend U0830.

### IMSIDs When IMSplexes and MSC Coexist

The IMSplex uses IMSIDs to identify IMS systems and to route any messages that have an affinity to a specific IMS system. IMSIDs must be unique within each IMS in an IMSplex. In an IMSplex-MSC network, IMSIDs must be unique throughout the entire MSC network, even the remote MSC IMS systems outside of the IMSplex.

IMSIDs are not required to be unique in MSC networks that do not include an IMSplex. When migrating an MSC network to an IMSplex with shared queues, make sure the IMSIDs of each IMS system are unique.

## Managing Remote Transactions for APPC and OTMA When MSC and IMSplexes Coexist

Read this topic if:

- You are migrating from an MSC network to an IMSplex and you processed synchronous APPC and OTMA messages remotely in the MSC network
- You have an IMSplex and an MSC network that coexist and you want to process APPC and OTMA messages on a remote IMS system outside of the IMSplex

### Remote Processing of APPC and OTMA Messages in an MSC Network

In an MSC network, you can bypass local affinity for synchronous APPC and OTMA messages by queuing them to remote transactions that have SYSIDs specified. For the purposes of migration, you can use the same remote transactions in an IMSplex with shared queues. Any IMS system in the IMSplex that registers an interest in the remote transactions can process them.

Remote IMS systems process APPC and OTMA messages asynchronously and disassociated with the APPC or OTMA conversation. IMS does not propagate or cascade APPC or OTMA conversations to the remote IMS system. IMS saves an APPC or OTMA token in the message prefix. When a response or program-to-program switch returns to the originating IMS system, IMS attempts to restore the synchronous APPC or OTMA conversational mode to the message.

To enable the remote processing of an APPC or OTMA message in an MSC network, queue the message to a remote transaction.

### Back-end Processing of APPC and OTMA Remote Transaction Messages in an IMSplex with Shared Queues

You can use remote MSC transactions to process APPC and OTMA messages in back-end IMS systems in an IMSplex. If you previously used remote transactions to process APPC and OTMA messages in an MSC network, this can be helpful when migrating to an IMSplex with shared queues. For transactions native to the IMSplex environment, there is no local affinity requirement.

**Related Reading:** For more information on APPC and OTMA messages in an IMSplex environment, see “Managing APPC and OTMA Messages in a Sysplex Environment” on page 115.

When using a remote transaction to process APPC and OTMA messages in an IMSplex, the APPC and OTMA messages do not process on the back-end in a synchronous APPC or OTMA conversational mode. IMS does not propagate or cascade the APPC and OTMA conversation to the back-end IMS system. When a response or program-to-program switch returns to the originating IMS system, IMS attempts to restore the synchronous APPC or OTMA conversational mode to the message.

### Enabling Back-end Processing of APPC and OTMA Messages Using a Remote Transaction

To use a remote transaction to process APPC and OTMA messages on back-end IMS systems within an IMSplex, take these steps:

- Define MSC in all IMS systems in the IMSplex.
- Define at least one MSC link in each IMS system in the IMSplex. This MSC link can be either a functional link to a remote IMS system outside of the IMSplex or, if none exists, it can be a non-functional MSC link.

## MSC and IMSplex with Shared Queues

- In the IMS system connected to the APPC or OTMA client, define a remote transaction for the APPC or OTMA messages by specifying the SYSID= keyword of the TRANSACT macro:
  - The remote SYSID can be any remote SYSID.
  - The local SYSID should match the SYSID of the IMS system connected to the APPC or OTMA client.
- In all back-end IMS systems, define a local transaction to process the APPC or OTMA messages.
- Register the remote transaction with the IMSplex by starting the transaction and the dependent regions that will process it.

To process APPC and OTMA transactions on a remote MSC IMS system outside of an IMSplex, the user must:

- Have MSC defined in all IMS systems in the IMSplex.
- Define an MSC link between the IMSplex and the remote IMS.
- In any IMS system in the IMSplex, define a remote transaction and assign it to an MSC link by specifying remote and local SYSIDs in the SYSID= keyword of the TRANSACT macro:
  - The remote SYSID must match the SYSID of the remote MSC IMS system.
  - The local SYSID must match the SYSID of the IMS connected to the APPC or OTMA client.
- In the remote IMS, define a local transaction to process the APPC or OTMA transaction message.

### **How IMS Routes APPC and OTMA Remote Transaction Messages for Back-end Processing in an IMSplex with Shared Queues**

In an IMSplex with shared queues, when an APPC or OTMA message is queued to a transaction defined as remote, IMS inserts the transaction message to the shared queue without affinity to any IMS system. Any IMS system in the IMSplex that has the transaction defined as local and assigned to a region can then process the transaction.

When a back-end IMS system retrieves APPC and OTMA transaction messages from a shared queue, it saves an APPC or OTMA conversation token in the message prefix and processes the transaction message independently from, and asynchronous to, the APPC or OTMA conversation. When the originating front-end IMS system receives a response or program-to-program switch, IMS restores the message to its original APPC or OTMA mode.

When IMS inserts a response message to the IMS system connected to the APPC or OTMA client, if the original input message mode was synchronous, IMS tries to resume processing it synchronously. If IMS cannot resume synchronous processing, the response is queued as asynchronous output. If the mode is synchronous and multiple response messages are inserted, only the first response message to arrive on the front-end IMS system is queued synchronously. The other messages are queued asynchronously.

If a program-to-program switch message is processed on the front-end IMS system due to a registered interest for the transaction, the message will be restored to the APPC or OTMA conversation and processed synchronously if the APPC or OTMA client is still active and in synchronous mode. Otherwise, IMS processes the message asynchronously. If the APPC or OTMA client is unavailable, IMS does not discard the message as it would for transactions processed in a local synchronous mode.

## Avoiding Pseudoabend U0830

When an MSC network and an IMSplex with shared queues coexist, errors can occur if you remove IMS systems from, or add them to, the IMSplex or MSC network while messages remain on the shared queues or in flight within the MSC network. Errors can also occur if the definitions used to route the messages, such as SYSIDs, IMSIDs, or destination names, are changed.

In an IMSplex with MSC, IMS validates SYSIDs, IMSIDs, and destination names when IMS systems retrieve transaction messages from the shared queue for processing. If validation fails, IMS leaves the transaction message on the shared queue and issues a pseudoabend U0830. By taking these precautions you can avoid most U0830 pseudoabends:

- Prior to migrating or moving IMS systems, remove all transactions destined for the IMS systems being migrated or moved from the shared queues and the MSC network.
- Prior to changing any SYSIDs, IMSIDs, or MSNAMEs, remove all transactions that use these identifiers from the shared queues and the MSC network.
- After migrating new IMS systems into an IMSplex, wait for all the IMS systems to join the IMSplex and all SYSID tables to be updated before you start dependent regions to process messages
- When restarting multiple IMS systems with MSC definitions in an IMSplex, if all local SYSIDs in the IMSplex have not been cloned in each IMS system, wait for all of the IMS systems to finish restarting before starting any dependent regions. Until restart is complete, some SYSID tables might not include all of SYSIDs that are not cloned.

---

## TM and MSC Message Routing and Control User Exit Routine

Message routing is automatic, according to the defined scheme, unless you use the TM and MSC Message Routing and Control User Exit routine (DFSMSCE0). This exit routine provides routing options and control of messages. It also provides a single parameter list, and the ability to append optional user prefixes to messages for customizing message routing and security.

This routing exit routine is called before the message destination is final. The entry points of the exit routine are:

- **Terminal routing (TR):** Receives control when a message is received from a terminal.
  - BTAM messages (TRBTAM)
  - VTAM messages (TRVTAM)
  - APPC messages (TRAPPC)
  - OTMA messages (TROTMA)
- **Link receive (LR):** Receives control when a message is received on a MSC link.
  - Local transaction messages (LRTRAN)
  - Local LTERM messages (LRLTERM)
  - Local direct routing messages (LRDIR)
  - Intermediate messages (LRINT)
- **Program routing (PR):** Receives control when the application program issues a CHNG or ISRT call to insert a message.
  - Application program CHNG call (PRCHNG)
  - Application program INST call (PRINST)

## MSC Exit Routine

**Note:** Using this exit routine does not require Multiple Systems Coupling (MSC), though most of its options only work if MSC is enabled.

The TM and MSC Message Routing and Control User Exit routine is loaded during IMS initialization, provided it exists in the JOBLIB, STEPLIB, or LINKLIST library that is concatenated in front of IMS.SDFSRESL. There are no SYSGEN or startup parameter modules needed to invoke this exit routine.

You can append optional user-defined prefixes to messages. Message prefixes can be used, for example, to customize message security, user accounting, and statistics requirements, and to increase routing control by allowing communications among exit routines. This user message prefix segment can be added to the message and updated as the message is routed through the MSC/TM network as each exit routine entry point is called. These other exit routines can read or update the prefix segment. The user prefix segment can be used offline. The user prefix size is limited to 512 bytes, and the total message prefix size is limited to the large message queue LRECL.

**Related Reading:** See the Message Prefix Size Table under the MSGQUEUE macro in *IMS Version 9: Installation Volume 2: System Definition and Tailoring*.

The TM and MSC Message Routing and Control User Exit routine uses a common parameter list interface for all of the entry points. DSECTS are provided to reference all parameter fields. You can select the entry points at which the exit routine should take control by changing and reassembling pointers in the DFSMCCSV macro in the front of the user exit module. IMS calls the exit routine if the entry point exists.

**Recommendation:** Providing a DSECT for common reference to the parameter fields makes it easier to pass additional data to the exit routines in the future, such as performance or path availability data for use in making routing decisions. Data might include SIO rates, response times, or queue counts.

**Related Reading:** For more information on how to code the TM and MSC Message Routing and Control User exit routine (DFSMSCE0), see *IMS Version 9: Customization Guide*.

## Terminal Routing

The terminal routing entry points of the TM and MSC Message Routing and Control User Exit routine exist in the input system. The exit routine is called when a message is received from a terminal. The exit routine can inspect the specified destination (LTERM or transaction code) and, if specified, reject it or change it to any local or remote destination. If the exit routine does not change the destination, the originally specified destination is used for routing. The exit routine can also override a local LTERM or transaction to route a message to a remote IMS instead.

IMS does not call the exit routine for commands or from a terminal that is continuing a conversation.

In a configuration using horizontal partitioning, the exit routine can be used to evaluate all input messages and route them to the appropriate processing system based on information in the first segment of the input message. If transactions and links are appropriately defined, the exit routine can also be used to set a common destination for a set of input messages. On arriving at the destination system, the messages are processed according to their individual transaction codes.

## Link Receive

The Link Receive entry points of the TM and MSC Message Routing and Control User exit routine can change the transaction code or LTERM name of a message when IMS receives the message from an MSC link. It can inspect the transaction code or the LTERM name that is used as the destination and, if specified, reject it or change it to another destination with the same attributes. The exit routine can also examine the first segment of the message to determine what the new transaction code should be. If the exit routine does not change the transaction code, the destination remains the location that is specified by the original transaction code.

## Program Routing

The program routing points of the TM and MSC Message Routing and Control User exit routine allow you to control the routing of a message when an application program issues a CHNG or ISRT call. With these entry points, you can change the destination of the message or request to reject a message.

You can use the exit routine to avoid defining unique names for remote LTERMs and transactions. With the exit routine, you can have the same name for terminals throughout your MSC network. You can use this exit routine to execute the DL/I CHNG or ISRT call for the application program, and to change the destination from local to remote.

## MSC Exit Routine



## Part 5. Intersystem Communication

<b>Chapter 12. Overview of Intersystem Communication</b> . . . . .	253
What is ISC? . . . . .	253
Comparing ISC to MSC . . . . .	254
IMS Facilities Available to ISC . . . . .	255
Distributed Transaction Processing . . . . .	255
Distributed Services . . . . .	256
IMS Transaction Types . . . . .	256
IMS Execution Modes . . . . .	256
IMS Editing Facilities . . . . .	256
ISC Message Integrity . . . . .	257
ISC Security . . . . .	257
ISC in an XRF Complex . . . . .	257
Sample System Configurations . . . . .	258
ISC between IMS and CICS . . . . .	259
Terminal Device-Dependent Data . . . . .	260
Passing CICS Data to IMS . . . . .	261
<b>Chapter 13. VTAM Facilities Used for ISC</b> . . . . .	263
VTAM Commands and Indicators . . . . .	264
Using the VTAM Application Program Interface . . . . .	265
Specifying Logon Modes When Establishing Connection . . . . .	265
Design Considerations for Secondary Logical Units . . . . .	266
<b>Chapter 14. IMS Facilities Affected by ISC</b> . . . . .	269
Editing Messages . . . . .	269
Issuing IMS Commands from an ISC Session . . . . .	270
Effects on Parallel Sessions . . . . .	270
Using IMS Test Mode for ISC Sessions . . . . .	271
IMS Control Block Storage on ISC Parallel Sessions . . . . .	271
Relationship of ISC and IMS Execution Modes . . . . .	272
External Specification of Execution Modes . . . . .	272
Internal Definition of Execution Mode . . . . .	273
Resultant Processing Mode . . . . .	273
LTERM Users (Subpools) and Components . . . . .	274
<b>Chapter 15. Designing Communications Using the ISC Protocol</b> . . . . .	277
Determining Output Protocols . . . . .	277
Accessing Existing Application Programs with ISC . . . . .	278
Accessing Programs That Use MFS . . . . .	279
Accessing Programs That Do Not Use MFS . . . . .	279
Routing Messages . . . . .	280
Considerations for IMS-to-IMS ISC Sessions . . . . .	288
Statically Defining an ISC Node to IMS . . . . .	291
Choosing Parameters: System Design Considerations . . . . .	293
COMM Macro Statement . . . . .	293
NAME Macro . . . . .	294
SUBPOOL Macro . . . . .	294
TERMINAL Macro . . . . .	295
System Definition Summary . . . . .	296
<b>Chapter 16. ISC Protocol Guide and Reference</b> . . . . .	299
Operating the Network . . . . .	300
Making IMS Ready . . . . .	300
Bringing Up an IMS Network . . . . .	300
Shutting Down an IMS Network . . . . .	300
Controlling the Session (Session Control Protocols) . . . . .	301
Initiating a Session . . . . .	301
Establishing a Connection with an XRF Complex . . . . .	302
Binding the Session . . . . .	302
Resynchronizing Sessions . . . . .	304
Designing Restart Resynchronization Procedures . . . . .	305
Determining Session Synchronism Using STSN . . . . .	310
Performing the Resynchronization . . . . .	311
Completing Session Initiation . . . . .	312
Running the Session . . . . .	313
Terminating the Session . . . . .	313
Normal Termination . . . . .	313
Abnormal Termination . . . . .	314
Using STSN to Resynchronize Sessions . . . . .	314
Primary-to-Secondary Flow Matrix . . . . .	314
Secondary-to-Primary Flow Matrix . . . . .	315
STSN Command Format . . . . .	317
Handling IMS Response Mode or Conversational Output Errors . . . . .	319
Response Mode Errors . . . . .	319
Conversational Mode Errors . . . . .	320
Normal Conversation Termination Extension with ISC . . . . .	321
Keeping Half Sessions Synchronized . . . . .	321
Sync Points Requested on Input to IMS . . . . .	322
Sync Points Requested on Output by IMS . . . . .	323
Sync Point and Response Requirements . . . . .	323
Sync-Point Indicators on Messages . . . . .	326
Data Flow Control Protocol Reference . . . . .	329
BID Protocol . . . . .	330
Bracket and Half-Duplex Protocol . . . . .	330
CANCEL Protocol . . . . .	338
Chaining Protocol . . . . .	339
CHASE Protocol . . . . .	339
ERP Purging . . . . .	340
LUSTATUS Protocol . . . . .	343
Paged Messages ERP . . . . .	346
Ready-to-Receive Protocol . . . . .	346
RSHUT Protocol . . . . .	347
Selective Receiver ERP . . . . .	347
Sender ERP . . . . .	351
Sense Codes that IMS Receives . . . . .	353
Sense Codes that IMS Sends . . . . .	354
SIGNAL Protocol . . . . .	355
Symmetrical Session Shutdown for LU 6.1 (SBI and BIS) . . . . .	355
Function Management Headers . . . . .	356
Using FM Headers to Invoke ISC Edit . . . . .	358
Initiating a Process: ATTACH FM Header . . . . .	358
Error Recovery Procedure FM Header . . . . .	359
Resetting the Active Process: RAP FM Header . . . . .	359

Requesting Asynchronous Transaction Processing: SCHEDULER FM Header . . . . .	360
System Message Process (SYSMSG) and Related FM Headers . . . . .	361
<b>Chapter 17. Using MFS with ISC . . . . .</b>	<b>363</b>
Activating MFS Input Formatting . . . . .	363
Activating MFS Output Formatting . . . . .	364
MFS Distributed Presentation Management (DPM) Messages . . . . .	364
MFS Page Delete Function . . . . .	365
MFS Online Error Detection . . . . .	365
Output Errors . . . . .	365
Input Errors . . . . .	365
Paging Errors . . . . .	366
The ATTACH and SCHEDULER FM Headers under MFS . . . . .	367
Data Descriptor FM Headers . . . . .	368
Input Data Descriptor FM Header . . . . .	368
Output Data Descriptor FM Header . . . . .	368
Controlling Demand-Paged Messages: QMODEL FM Headers . . . . .	369
Request (Input) QMODEL FM Headers . . . . .	370
QGETN FM Header . . . . .	370
QGET FM Header . . . . .	370
QPURGE FM Header . . . . .	371
Reply (Output) QMODEL FM Headers . . . . .	371
QXFR FM Header . . . . .	371
QSTATUS FM Header . . . . .	372
The RAP FM Header under MFS . . . . .	372
<b>Chapter 18. FM Header Format Reference . . . . .</b>	<b>373</b>
ATTACH FM Header Format . . . . .	373
ATTIU . . . . .	375
ATTDSP . . . . .	376
ATTDDBA . . . . .	377
ATTDPN . . . . .	378
ATTPRN . . . . .	379
ATTRDPN and ATTRPRN . . . . .	380
ATTDQN and ATTDQ . . . . .	381
ATTACC . . . . .	381
Data Descriptor FM Headers . . . . .	382
Error Recovery Procedure (ERP) FM Header . . . . .	383
QMODEL FM Headers . . . . .	383
QGET FM Header Format . . . . .	384
QGETN FM Header Format . . . . .	385
QPURGE FM Header Format . . . . .	386
QSTATUS FM Header Format . . . . .	387
QXFR FM Header Format . . . . .	387
Reset Attached Process (RAP) FM Header Format . . . . .	390
SCHEDULER FM Header Format . . . . .	390
SYSMSG Process Headers . . . . .	391
SYSERROR FM Header Format . . . . .	391
SYSSTAT FM Header . . . . .	392

---

## Chapter 12. Overview of Intersystem Communication

This chapter introduces the System Network Architecture (SNA) for Intersystem Communication (ISC) and the IMS implementation of this architecture.

### **In this Chapter:**

- “What is ISC?”
- “Comparing ISC to MSC” on page 254
- “IMS Facilities Available to ISC” on page 255
- “Sample System Configurations” on page 258
- “ISC between IMS and CICS” on page 259

---

### What is ISC?

ISC is a part of the IMS Transaction Manager. It is one of the ways to connect multiple subsystems. The other means of connection is Multiple Systems Coupling (MSC).

As defined under SNA, ISC is an LU 6.1 session that:

- Connects different subsystems to communicate at the application level.
- Provides distributed transaction processing permitting a terminal user or application in one subsystem to communicate with a terminal or application in a different subsystem and, optionally, to receive a reply. In some cases, the application is user written; in other cases, the subsystem itself acts as an application.
- Provides distributed services. Thus, an application in one subsystem can use a service (such as a message queue or database) in a different subsystem.

SNA makes communication possible between unlike subsystems and includes SNA-defined session control protocols, data flow control protocols, and routing parameters. The functions provided by each of these protocols and parameters are summarized below, and the IMS support for them is described in this chapter.

**Related Reading:** For more information on the SNA protocols and parameters, see Chapter 16, “ISC Protocol Guide and Reference,” on page 299.

Session control (SC) comprises:

- Initiating sessions between subsystems
- Recovering and resynchronizing sessions, maintaining the integrity of session states and recoverable resources across both session and subsystem failures
- Terminating any or all session paths between IMS and another subsystem

Data flow control (DFC) includes:

- Controlling send and receive protocols within a session.
- Resolving contention for transaction initiation within a session.
- Monitoring error recovery processing.
- Monitoring symmetrical shutdown accomplished using the SNA commands stop bracket initiation (SBI) and bracket initiation stopped (BIS).

- Controlling synchronization of resources. Sync point control ensures that all resources are committed or backed out synchronously.

ISC routing comprises:

- Using parameters in the SNA-defined function management headers to connect the process required for incoming messages and to route reply messages.

APPC/IMS only supports message switching to LU 6.2 destinations through the DFSAPPC service.

**Related Reading:** For information on the DFSAPPC service, see:

- “DFSAPPC System Service” on page 427
- “ETO and LU 6.1 (ISC) Terminals” on page 190

---

## Comparing ISC to MSC

IMS provides two ways to couple multiple subsystems: MSC (multiple systems coupling) and ISC (intersystem communication).

Multiple Systems Coupling (MSC) is an IMS protocol that enables coupling of IMS systems to other IMS systems only. Intersystem Communication (ISC), however, allows you to connect IMS subsystems with any other subsystem that supports the ISC protocol. This other system can be another IMS, CICS, or a user-written system.

MSC supports three types of links between IMS systems—channel-to-channel (CTC), memory-to-memory (MTM), and VTAM. In the balance of this chapter, MSC is used to identify the functions provided by any of these links. ISC uses only one kind of link—LU 6.1. Figure 40 compares MSC to ISC.

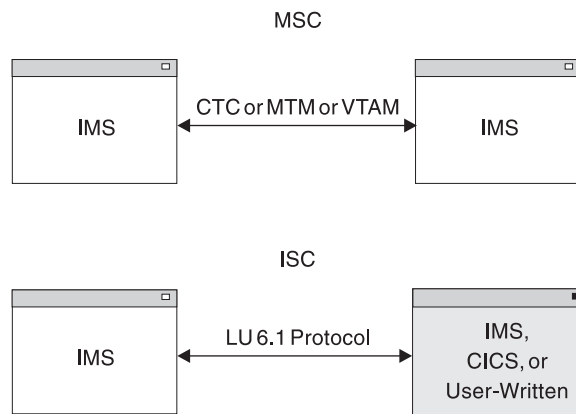

Figure 40. IMS Multiple Systems Coupling and Intersystem Communication

Both MSC and ISC enable a user to:

- Route transactions
- Distribute transaction processing
- Grow beyond the capacity of one IMS system

Also, both ISC and MSC take advantage of the parallel session support VTAM provides. Some key differences exist, however. Table 20 on page 255 highlights the major functions of MSC and ISC, and shows the differences in support.

Table 20. Comparing MSC and ISC Functions

MSC Functions	ISC Functions
MSC connects multiple IMS systems only to each other. These IMS systems can all reside in one processor, or they can reside in different processors.	ISC can connect either like or unlike subsystems, as long as the connected subsystems both implement ISC. Thus, a user can couple an IMS subsystem to: <ul style="list-style-type: none"> <li>• Another IMS subsystem</li> <li>• A CICS subsystem</li> <li>• A user-written subsystem</li> </ul>
Communication in the MSC environment is subsystem-to-subsystem.	Communication is between application programs in the two subsystems. The subsystems themselves are session partners, supporting logical flows between the applications.
Processing is transparent to the user. That is, to the user, MSC processing appears as if it is occurring in a single system.	Because ISC supports coupling of unlike subsystems, message routing requires involvement by the terminal user or the application to determine the message destination. Specified routing parameters can be overridden, modified, or deleted by MFS.
When not using the MSC-directed routing capability, the terminal operator or application program does not need to know routing information. Routing is automatic based on system definition parameters.	ISC provides a unique message-switching capability that permits message routing to occur without involvement of a user application.
MSC supports the steps of a conversation to be distributed over multiple IMS subsystems, transparent to both the source terminal operator and to each conversational step (application).	ISC supports the use of Message Format Service (MFS) in an IMS subsystem to assist in the routing and formatting of messages between subsystems.
MSC does not support the use of the Fast Path Expedited Message Handler (EMH).	ISC supports the use of Fast Path Expedited Message Handler (EMH) between IMS subsystems.

**Related Reading:** For more information on MSC, see Chapter 11, “Administering Multiple Systems Coupling,” on page 213.

## IMS Facilities Available to ISC

This topic describes a variety of IMS facilities that are available to ISC.

### Distributed Transaction Processing

When supporting distributed transaction processing, IMS can be either the front-end or back-end processor. A front-end subsystem originates communications traffic (transactions, commands, or message switches) that are to be processed by the back-end subsystem. A message is typically the result of data entered at a terminal. However, the message can also result from processing that occurred in an application within the front-end subsystem. The back-end subsystem processes input messages from another subsystem.

In the most typical configuration, IMS is the back-end system and processes IMS transactions that another subsystem enters.

In addition, special support exists for front-end or back-end system utilization is provided by the Front-End Switch exit routine.

**Related Reading:** For more information on the Front-End Switch exit routine (DFSFEJ0), see *IMS Version 9: Customization Guide*.

Sometimes, transactions entered into an IMS front end are sent with an ISC message switch to the other subsystem. In this case, the terminal operator or MFS provides the message routing information. The transaction can also be sent as alternate program communication block (PCB) output, in which a user-written application program or MFS format definition provides the routing information.

The fact that IMS is a queued subsystem is a key factor in determining the ISC functions that it supports, particularly when IMS acts as a front-end processor. Messages created by a terminal operator or an application in a front end IMS are queued for transmission to the receiving subsystem and sent asynchronously with respect to the terminal or application that sent the message. A terminal attached to an IMS front-end is not held in response mode during the receiving (back-end) subsystem's processing, unless it uses the Front-End Switch exit routine (DFSFEJ0).

## Distributed Services

IMS supports distributed services by providing remote access to an IMS message queue. Although IMS does not support distributed DL/I calls, a DL/I database in one subsystem can be updated by another subsystem; this action requires the sending subsystem to invoke an updating application in the receiving subsystem.

## IMS Transaction Types

IMS supports the following transaction types:

- Recoverable-update (includes Fast Path)
- Recoverable-inquiry
- Irrecoverable-inquiry

**Related Reading:** For more information on transaction types, see *IMS Version 9: Administration Guide: System*.

## IMS Execution Modes

IMS supports the following execution modes:

- Response mode (includes Fast Path)
- Conversational mode
- Exclusive mode
- Transaction preset mode
- Test mode
- Non-response or nonconversational mode

**Related Reading:** For more information on execution modes, see *IMS Version 9: Administration Guide: System*.

## IMS Editing Facilities

Messages transmitted on the ISC session and processed within an IMS subsystem are edited by the following editing facilities:

- ISC edit (the default editor)
- Message Format Service (MFS)
- Basic edit

These editors can be selected on a message-by-message basis.

**Related Reading:** For a description of these editors, see “IMS Editing for Intersystem Communication (ISC)” on page 84.

## ISC Message Integrity

Message integrity is provided to prevent loss or duplication of input or output messages between IMS and another half session during session restart.

Message integrity and recovery are increased by log write-ahead (LWA). This facility is invoked during system definition by an option on the TRANSACT macro. LWA ensures that sync point information is written to the log (and thus available to IMS restart procedures) before IMS acknowledges the message.

**Related Reading:** For more information on message integrity, see “Resynchronizing Sessions” on page 304 and “Sync Point and Response Requirements” on page 323.

## ISC Security

IMS security facilities control access to IMS resources by another subsystem. Before implementing ISC security in IMS, examine the data protection facilities of the subsystems and associated operating system components. Some important ISC-environment security factors are described here.

Terminal operator verification and authorization are provided by the subsystem controlling that terminal connection.

Both IMS terminal and password security can be defined for static ISC terminals by using resource access control facility (RACF) or security maintenance utility (SMU) (IMS will not support SMU after IMS Version 9). If password security is defined, a password must be provided with the input message.

**Related Reading:** For more information on password security, see:

- “Password Security” on page 46
- “ETO and LU 6.1 (ISC) Terminals” on page 190
- *IMS Version 9: Administration Guide: System*

## ISC in an XRF Complex

ISC sessions are handled as class-2 or class-3 terminals. If the active IMS system fails, all LU 6.1 sessions are terminated. The alternate (now active) IMS system reestablishes the sessions after it takes control of the complex. Users might be without service for a short time.

**Related Reading:**

- For information on establishing an ISC session with an XRF complex, see “Establishing a Connection with an XRF Complex” on page 302.
- For more information on XRF, see *IMS Version 9: Operations Guide* and *MVS/ESA™ Planning: Extended Recovery Facility (XRF)*.

## Sample System Configurations

The following figures illustrate some IMS ISC configurations. The first two figures use the Customer Information Control System/Virtual Storage (CICS) product as an example of an ISC node.

Figure 41 illustrates ISC's distributed transaction processing capability—the ability to invoke existing or new IMS transactions from a CICS application or from a CICS application on behalf of a CICS-attached terminal (using transaction routing).

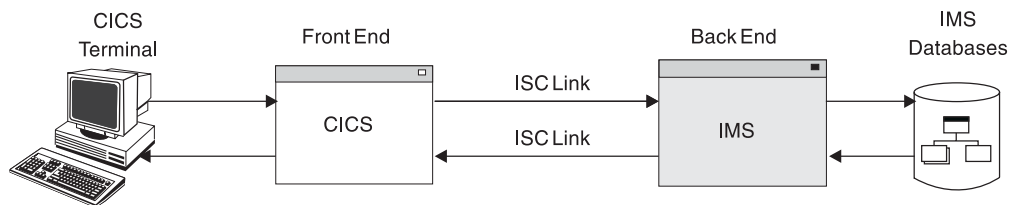

Figure 41. Existing or New IMS Transactions Invoked from CICS

In Figure 41, ISC provides transaction-to-transaction capability, because an application program can be written as two complementary transactions: one executing in an IMS system, the other in a CICS system. User functions can be distributed between systems as required.

Figure 42 illustrates ISC's ability to distribute device mapping function from an IMS Message Format Service (MFS) system to a CICS Basic Mapping Support (BMS) system. MFS partially maps the data stream that is sent to a CICS application. The application is responsible for processing the input data stream to a form that is acceptable to BMS. BMS can then be used to complete the device mapping.

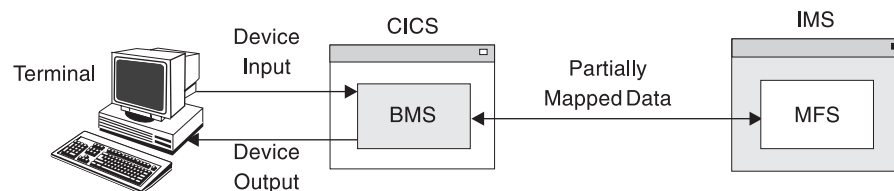

Figure 42. IMS MFS DPM Mapping Function Distributed to CICS's BMS

Figure 43 on page 259 illustrates how two IMS systems can be connected using ISC. Interconnection of two IMS systems allows a new or modified transaction (TRAN1) in one IMS system to invoke an existing transaction (TRAN2) in another IMS system. Using MFS, replies can be routed to a new transaction (TRAN3) in the initiating IMS system, or to a new instance of the originating transaction (TRAN1). Without MFS, replies are treated as message switches and routed to the source terminal.



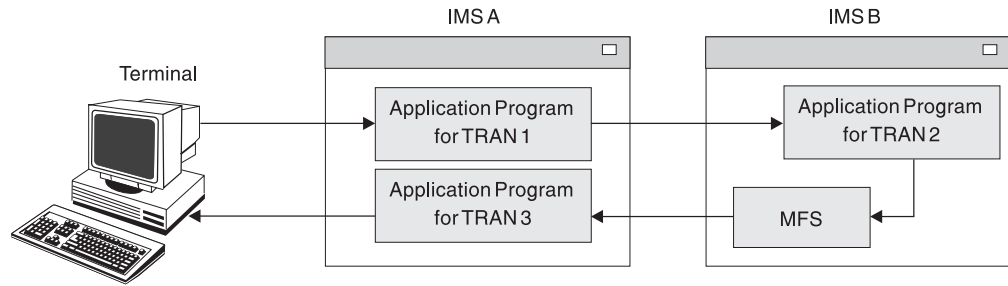

Figure 43. IMS-to-IMS with ISC

Figure 44 illustrates how a CICS subsystem can communicate with an IMS subsystem that has MSC links to other IMS subsystems. In this case, MSC is used to couple the IMS subsystems, while the CICS-to-IMS session is supported by ISC. The CICS subsystem has a single-system view of the multiple IMS subsystems with which it can communicate. MSC distributes the load between the multiple IMS subsystems.

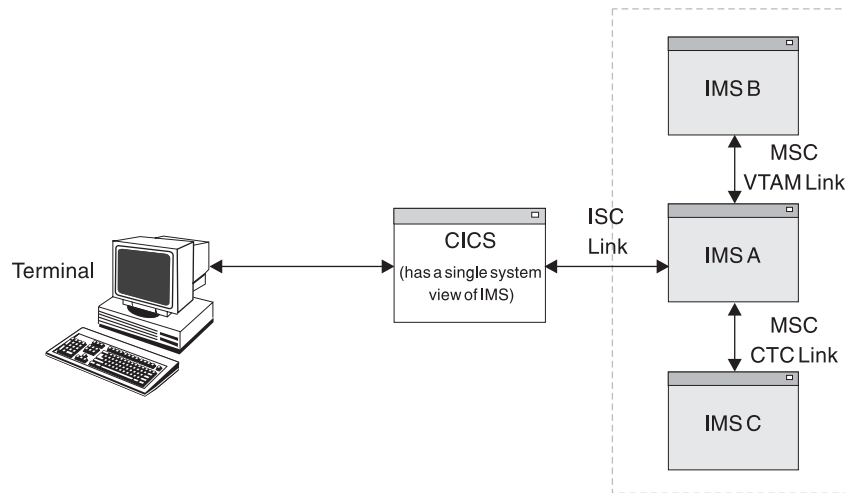

Figure 44. CICS-to-IMS MSC Using ISC

The intersection of functions provided by IMS and CICS is summarized in the next topic.

**Related Reading:** For a sample program illustrating the use of ISC between IMS and CICS, see Appendix J, “Sample Program for IMS-CICS ISC,” on page 593.

## ISC between IMS and CICS

Table 21 on page 260 identifies the ISC functions that are provided by CICS and IMS, and the IMS facilities that are available to users of CICS START or RETRIEVE, and SEND or RECEIVE.

**Related Reading:** For more information on the interaction of IMS and CICS in an ISC session, see Appendix G, “How IMS and CICS Use the ISC Interface,” on page 535.

Table 21. Facilities Available to CICS START RETRIEVE and SEND RECEIVE USER

Function	Front-End System	Back-End System
Distributed Transaction Processing	CICS <sup>1</sup>	CICS <sup>1</sup>
Initiate remote transaction	CICS <sup>1</sup>	IMS non-response type
	IMS all transaction types <sup>2</sup>	CICS <sup>1</sup>
	IMS all transaction types except conversational <sup>2</sup>	IMS all transaction types except conversational <sup>2</sup>
Distributed Transaction Processing	CICS <sup>3</sup>	CICS <sup>3</sup>
Application-to-Application Conversation	CICS <sup>3</sup>	IMS Response Conversational Fast Path
Distributed Presentation Management	IMS MFS map	IMS MFS map
Using distributed transaction processing	CICS user application <sup>4</sup> IMS MFS map	IMS MFS map CICS user application <sup>4</sup>

**Note:**

1. Using CICS START or RETRIEVE commands.
2. If the transaction in the processing subsystem is a response mode or Fast Path transaction, a nonresponse transaction type is required in the originating system to handle the reply from the processing subsystem.
3. Using CICS SEND or RECEIVE commands.
4. The user application can optionally invoke BMS to aid in mapping functions between CICS and the terminal.

## Terminal Device-Dependent Data

ISC, when used with IMS, is a technique that allows programs in various subsystems (IMS, CICS, and user-written) to exchange messages with application programs in other subsystems. To minimize or eliminate the need to modify these programs, the messages that are exchanged should not contain device control characters that are unique to the originating or destination terminal.

The device control editing facilities of IMS (MFS) or CICS (BMS) should be used to remove these device control codes prior to the initiating program creating its ISC message. Likewise, the program that sends the response to a terminal should use the formatting service of its own subsystem to properly format the message before sending it. This way, all inter-program message exchanges can be independent of the originating and destination terminals. This means that each terminal's owning system should understand all formats for transactions that can be entered or received by terminals on that system.

## Passing CICS Data to IMS

Users want their front-end application programs to receive 3270 data streams from an attached terminal and to simply pass through this data stream (device control characters) to the back-end IMS. The resulting output from IMS should then be a 3270 data stream that could be passed through the front-end application and out to the 3270.

### Pass-Through Input to IMS

It is possible to send a 3270 data stream from a front-end application to IMS. However, IMS does not recognize the ISC session as a 3270 device and does not edit the device control characters from the data stream. Your IMS application program must provide this editing function.

### Output from IMS

Similarly, IMS does not place 3270 device control characters in an output data stream that is destined for an ISC LTERM, because the ISC LTERM is not a 3270 device. Your application program must then construct a 3270 data stream to be sent to a front-end application that can, with minimal editing, send this data stream to an attached terminal.

This effort needs to be repeated for each device and each application program, and again after any change to a device format.



---

## Chapter 13. VTAM Facilities Used for ISC

VTAM controls the physical transmission of data between IMS and a logical unit. Both VTAM applications (such as IMS) and other subsystems can be viewed as VTAM logical units.

**Definition:** A *logical unit* is an addressable resource, such as an application program or a subsystem. A logical unit can also be a component of a general-purpose terminal system.

**Related Reading:** For more information on the communication concepts and facilities that govern data transmission between a VTAM application program (such as IMS) and another subsystem, see *Communications Server: SNA Programming*.

### **In this Chapter:**

- “VTAM Commands and Indicators” on page 264
- “Using the VTAM Application Program Interface” on page 265
- “Specifying Logon Modes When Establishing Connection” on page 265
- “Design Considerations for Secondary Logical Units” on page 266

The VTAM concepts and facilities used by IMS that are particularly relevant to ISC include:

- Connection, disconnection, and establishing logon mode.
- Messages and responses.
- Request definite response 1 (RQD1) or request definite response 2 (RQD2) and the associated definite responses (DR1 or DR2).<sup>25</sup>
- Sequencing and chaining.
- Orderly session disconnection from stop bracket initiation (SBI) and bracket initiation stopped (BIS) commands.
- Facilities for ensuring orderly communication, including the use of brackets and change-direction indicators.
- Sequence number recovery.
- Receiving input and sending messages.
- Conditional bracket termination.
- Extended Error Recovery Procedure (EERP).
- Use of parallel sessions between ISC nodes.
- Support for both negotiable and nonnegotiable session bind parameters.

### **Related Reading:**

- For more information on SBI and BIS commands, see “Symmetrical Session Shutdown for LU 6.1 (SBI and BIS)” on page 355.
- For more information on using parallel sessions between ISC nodes, see “Using the VTAM Application Program Interface” on page 265.

---

25. Definite response 1 and definite response 2 have been separated and redefined for LU 6.1 protocols. RQD2 requests and DR2 responses are now known as sync-point requests and responses and are functionally independent of those responses associated with DR1. “Resynchronizing Sessions” on page 304 explains response requirements in detail.

## VTAM Facilities Used for ISC

IMS also supports the class-of-service (COS) and session-outage-notification (SON) facilities.

### Related Reading:

- For more information on the COS and SON facilities, see *IMS Version 9: Administration Guide: System*.
- For more information on all of these communications concepts and facilities, see *Systems Network Architecture Format and Protocol Reference: Architectural Logic*.

The ISC system programmer and system analyst must be familiar with these concepts and facilities in order to design and implement a communications interface between IMS and a remote subsystem using SNA LU 6.1 protocols.

---

## VTAM Commands and Indicators

VTAM commands and indicators (communication control information) are necessary for data transmission between an IMS application program and another VTAM logical unit. Table 22 shows which VTAM commands and indicators that IMS sends and receives during an IMS session (X=supported). Results are unpredictable if any unsupported commands or indicators are used.

Table 22. VTAM Commands and Indicators Sent and Received by IMS

VTAM Command or Indicator	IMS Sends as Primary Half Session, Receives as Secondary Half Session	IMS Sends as Secondary Half Session, Receives as Primary Half Session
<b>Independent of Session</b>		
Initiate session		Note 4
Procedure error	Note 1	Note 1
Terminate session		Note 5
<b>Session Control Commands</b>		
Bind	X	
Bind response		X
STSN	X	
STSN response		X
Start data traffic (SDT)	X	
SDT response		X
Unbind	X	X
<b>Normal (synchronous) Flow Indicators</b>		
Begin bracket (BB)	X	X
End bracket (EB)	X	X
Change direction (CD)	X	X
<b>Commands</b>		
BID	Note 3	X
CANCEL	X	X
CHASE	X	X
Logical unit status (LUSTATUS)	X	Note 2
Ready to receive (RTR)		X

Table 22. VTAM Commands and Indicators Sent and Received by IMS (continued)

VTAM Command or Indicator	IMS Sends as Primary Half Session, Receives as Secondary Half Session	IMS Sends as Secondary Half Session, Receives as Primary Half Session
Bracket initiation stopped (BIS)	X	
<b>Expedited (asynchronous) Flow Commands</b>		
Request shutdown (RSHUT)	X	Note 2
Signal	X	X
Stop bracket initiation (SBI)		X

**Notes:**

1. Sent by VTAM.
2. Not sent by IMS, but optionally sent by the other subsystem and received by IMS when IMS is a primary half session.
3. Not sent by IMS, but optionally sent by the other subsystem and received by IMS when IMS is a secondary half session.
4. Supported by internal VTAM forms of CINIT (LOGON exit).
5. Supported by internal VTAM forms of CTERM (NS and LOSTERM exits).

## Using the VTAM Application Program Interface

The VTAM application program interface (API) used by IMS for ISC consists of macro instructions and control blocks to allow IMS to:

- Establish connection or disconnection.
- Request and control the transfer of data between IMS and another logical unit.

To provide application-to-application communication, the VTAM API provides both a primary and a secondary session application interface. The primary interface is essentially the same as that used by IMS to support other VTAM nodes. However, the interface introduces some new macros and some additional parameters on existing macros.

**Related Reading:** For more information on defining IMS to VTAM, see:

- “Special Considerations If Your System Requires VTAM” in *IMS Version 9: Installation Volume 1: Installation Verification*
- *Communications Server: SNA Resource Definition Reference*

The VTAM API supports single sessions as well as parallel (multiple, simultaneously active) sessions between two logical units. The IMS interface for this support is primarily through the session qualifier fields of CINIT and BIND, which are available through the LOGON and SCIP exit routines. Single-session support requires static definition of message queues during IMS system definition; parallel-session support permits message queues to be dynamically allocated at session initiation.

## Specifying Logon Modes When Establishing Connection

When establishing connection, IMS requires that session parameters define the rules a logical unit must follow when communicating with IMS. These session parameters are contained in the VTAM mode table.

## Specifying Logon Modes When Establishing Connection

The use of the default logon mode table entry can be overridden in one of two ways:

- At system definition, the logon mode entry can be specified on the `TERMINAL` macro using the `MODETBL=keyword` or an ETO logon descriptor.
- The `MODETBL` keyword on the `/OPNDST` command can specify the logon mode table entry to replace the table entry defined at system definition.

### **Related Reading:**

- For information on specifying the `MODETBL` keyword, see *IMS Version 9: Installation Volume 2: System Definition and Tailoring*.
- For information on specifying the `/OPNDST` command, see *IMS Version 9: Command Reference*.

If neither method is used to specify a logon mode table entry, VTAM uses the first entry in the default logon mode table, unless it is overridden by VTAM node mode table entry definition. If a logon mode table entry is specified, VTAM searches the default or user-specified logon mode table for the specified entry.

IMS examines the set of session parameters within the indicated VTAM mode table entry and overlays only those parameters on which IMS has dependencies. The remaining bytes are not changed. IMS ignores any unformatted user data transmitted with the session parameters.

### **Related Reading:**

- For more information on the session parameters, see Appendix B, “Bind Parameters for SLU P and LU 6.1,” on page 503.
- For more information on establishing logon mode tables and defining logon mode table entries, see *Communications Server: SNA Resource Definition Reference*.

---

## Design Considerations for Secondary Logical Units

When IMS and another subsystem establish an ISC session, one session partner is the bidder and the other the first speaker (the contention winner). In an IMS ISC session, the bidder is always the primary logical unit (the bind sender), and the first speaker is always the secondary logical unit (the bind receiver). When providing a system design for a secondary logical unit that is to communicate with IMS within an ISC network, consider the following points:

- The first speaker (secondary logical unit) must resolve bracket contention and be prepared to receive interrupts (for example an VTAM command or bracket indicator) at all times. If the first speaker is not prepared to do so, a deadlock can result (for example, if both the primary logical unit and the secondary logical unit use the VTAM SEND macro, and issue `POST=RESPONSE` rather than `POST=SCHED`).
- When terminating a session using the VTAM `TERMSESS` macro, the system designer should be aware of the differences involved in issuing `CONDITIONAL` versus `UNCONDITIONAL`. Sending `CONDITIONAL` permits the primary logical unit to clean up and control session termination. Sending `UNCONDITIONAL` causes immediate termination of the session by VTAM prior to notification of the primary logical unit. If the primary logical unit is in a suspended state as, for example, when waiting for a response, the system designer should be aware that `UNCONDITIONAL` session termination can have unanticipated results.



## Design Considerations for Secondary Logical Units

The term “secondary logical unit” is synonymous with “first speaker” and the term “primary logical unit” with “bidder”.

|



---

## Chapter 14. IMS Facilities Affected by ISC

This chapter explains how IMS facilities are affected by ISC processing.

**Related Reading:** For more information on IMS facilities available to an ISC session, see:

- *IMS Version 9: Administration Guide: System*
- *IMS Version 9: Application Programming: Transaction Manager*

**In this Chapter:**

- “Editing Messages”
- “Issuing IMS Commands from an ISC Session” on page 270
- “Effects on Parallel Sessions” on page 270
- “Using IMS Test Mode for ISC Sessions” on page 271
- “IMS Control Block Storage on ISC Parallel Sessions” on page 271
- “Relationship of ISC and IMS Execution Modes” on page 272

---

### Editing Messages

Within IMS, the communication interface is transparent to application programs. In support of this, IMS provides some common editing that:

- Appends protocols and function management headers to outbound messages
- Strips function management headers from incoming messages and moves the messages to appropriate points within the IMS control blocks

Subsequent to this common editing, messages received by IMS are edited by ISC edit, Message Format Service (MFS), or basic edit in accordance with the input ATTACH or SCHEDULER DPN parameter. Messages sent by IMS are edited by Message Format Service before they are sent. The edit functions of ISC edit and basic edit are unique. However, the associated protocols are the same.

- ISC edit is the default editor. When ISC edit is requested and that request does not contain the SNA-defined PRN parameter following the input data, the message is edited with partial input data transparency. That is, only the IMS-required destination code and optional password, which must occur at the beginning of the message, are subjected to editing by ISC edit. The balance of the input message is not edited prior to processing unless the transaction is defined to translate to uppercase. Full input data transparency is provided through ISC edit using the SNA-defined PRN parameter on the ATTACH or SCHEDULER FM header. This enables the IMS transaction code to be external to the message and enables IMS to receive input and route it to its proper destination (terminal or transaction) without examining the input message itself. Because the transaction code is external to the data stream, the optional password is not available to the session. Therefore, password security should not be defined. If password security is defined, an error results.

**Related Reading:**

- For more information on the SNA-defined PRN parameter, see “FM Headers for Message Routing” on page 280.
- For more information on ISC edit, see “Using FM Headers to Invoke ISC Edit” on page 358.

## Editing Messages

- Message Format Service's Distributed Presentation Management (DPM) option divides responsibility for message formatting between MFS and a program residing in another subsystem. When using DPM-Bn, physical terminal characteristics are not defined to MFS. Instead, IMS sends MFS-formatted data to a program in the other subsystem. That program must complete the formatting, if necessary, and present the data to the physical device. DPM also allows user involvement in specifying input and output ISC message routing parameters. You can also use the PRN parameter on the ATTACH or SCHEDULER FM header to specify the IMS destination externally, relative to the resulting MFS-formatted input data stream.

**Related Reading:** For more information on MFS and the DPM option, see *IMS Version 9: Application Programming: Transaction Manager*.

- Basic edit provides standard editing for terminal input. It is used to edit device and operator control characters and can be used in an ISC session when it is important to maintain input compatibility for existing applications. Protocols for basic edit are the same as those for ISC edit. Use of the ATTACH or SCHEDULER FM header PRN parameter has no effect when basic edit is used. The message destination is determined from the first field of the input data stream.

**Related Reading:** For more information on the editing functions of basic edit, see "Basic IMS Edit Functions" in *IMS Version 9: Administration Guide: System*.

IMS permits basic edit, ISC edit, or MFS to be invoked in order to handle communication of transactions, commands, and message switches. MFS DPM facilities are defined as optional on a component-by-component basis. Any of these available processes are selectable on a message-by-message basis by using the ATTACH or SCHEDULER FM header.

ISC input and output can be edited by most IMS data communication exit routines. The exceptions are the MSC-related exit routines, and the hardware-required routines.

---

## Issuing IMS Commands from an ISC Session

Although available to the ISC session, IMS operator commands are primarily intended for use by appropriately authorized operators of IMS master terminals and remote terminals that are directly attached to an IMS system. Terminal operators of other (non-IMS) subsystems do not communicate directly with IMS, but rather with the control program or user-provided applications within the other subsystem. That subsystem must determine and provide procedures for its terminal operators and application programmers to follow when communicating with IMS. If an application in a non-IMS subsystem is permitted to issue IMS commands through the ISC session, IMS dependencies are introduced into that application. An ISC half session cannot be defined as the primary or secondary master terminal.

---

## Effects on Parallel Sessions

**Recommendation:** Be sure to include the USER keyword when using authorized IMS commands with the NODE keyword. Equivalent action is taken against all active, or potentially active, parallel sessions of the indicated node when a specific parallel session instance is not identified to IMS by the USER keyword.

**Example:** Issuing the /CLSDST NODE x command without specifying USER schedules termination of all active parallel sessions of NODE x. Issuing the /STOP NODE x

command without specifying USER schedules termination of all active parallel sessions of NODE x and also prevents any new parallel sessions from being initiated on NODE x.

---

### Using IMS Test Mode for ISC Sessions

You can test ISC communication protocols and editing facilities by putting a back-end IMS system into test mode.

While in test mode, IMS receives an input message, checks input protocols and FM header parameters, performs input and output editing, inserts appropriate output protocols and FM header parameters, and returns the message to the front-end subsystem. Noncommunication error analysis, transaction code verification, and transaction scheduling are bypassed. Also, IMS does not send asynchronous output while in test mode.

You can place one or all of the ISC sessions within a specific subsystem in test mode when the IMS /TEST command is received on the ISC sessions. The /TEST command can only be entered by the terminal that is being put into test mode. You can terminate test mode by sending an end-bracket (EB) indicator on an SNA LUSTATUS or CHASE command. Test mode can also be terminated when an /END command is received on the ISC session or is entered locally in the back-end IMS processor by an authorized terminal operator.

In an IMS-to-IMS environment, use the ISC message switch facility to place the back-end IMS system into test mode, to send the message and receive the echo reply, and to terminate test mode. This provides an efficient means of testing without requiring a user application in either subsystem.

---

### IMS Control Block Storage on ISC Parallel Sessions

The storage required for the IMS control block structure representing potential sessions is greater than the storage required for control blocks representing input and output message queues. Therefore, installations needing only a few logical units type 6.1, each having a relatively small number of associated parallel sessions, but each requiring that a large number of ISC users (subpools or LTERM sets) be dynamically allocated to them, can have lower storage requirements. For static ISC terminals, these users (subpools) are still statically defined. The IMS control block structure for ISC single session (statically defined and allocated LTERMs) is the same as for other static VTAM terminal types within IMS.

**Related Reading:** For information on the IMS control block structure for ISC parallel sessions, see Appendix H, "ISC Data Flow Control Examples," on page 579.

You do not need to define a maximum number of ETO-ISC sessions. You can continue to add sessions until you run out of storage and processor capacity. Therefore, the SESSION= keyword is not one of the supported keywords on the ETO descriptor. To define the maximum number of sessions for static ISC sessions, use the SESSION keyword on the TERMINAL macro.

**Related Reading:** For more information on actual storage requirements for ISC, see *IMS Version 9: Administration Guide: System*.

## Relationship of ISC and IMS Execution Modes

Because the terms “synchronous” and “asynchronous” have slightly different connotations within IMS and ISC, the following topics explain the relationship of these execution modes:

- “External Specification of Execution Modes”
- “Internal Definition of Execution Mode” on page 273
- “Resultant Processing Mode” on page 273
- “LTERM Users (Subpools) and Components” on page 274

### External Specification of Execution Modes

Messages in ISC use the SNA-defined function management headers. ISC-routed messages can be processed either synchronously or asynchronously, as determined primarily by the type of FM header and secondarily by the VTAM bracket protocols sent with the message. A summary of supported protocols appears in Table 23. Using FM headers and VTAM bracket protocols to establish the mode of the message (synchronous or asynchronous) can be considered to be external to the message.

#### Related Reading:

- For more information on the SNA-defined function management headers, see “Function Management Headers” on page 356.
- For more information on VTAM send, receive, and bracket protocols that are sent with ISC messages, see “Handling IMS Response Mode or Conversational Output Errors” on page 319.

*Table 23. Processing Mode Requested by FM Headers*

FM Header with VTAM Bracket Protocol	Synchronous	Asynchronous
ATTACH with CD	X	
ATTACH with EB		X
ATTACH without either EB or CD	X	
SCHEDULER with CD	X	X
SCHEDULER with EB		X
SCHEDULER without either EB or CD	X	X

Messages received by IMS with the ATTACH FM header are processed:

- Synchronously, if the session state is left “in-brackets” after the message has been received.
- Asynchronously, if either of the following occurs:
  - The session state is left “between-brackets” after the message has been received.
  - The message is sent with EB on the first- or only-in-chain.

During synchronous processing, unsolicited or asynchronous output is not sent.

All messages received by IMS with the SCHEDULER FM header are processed asynchronously by the receiver with respect to the session.

### Internal Definition of Execution Mode

The IMS internal execution mode determines how IMS processes a transaction. Response mode and conversational mode, for example, are used to ensure synchronism between a given input message and its associated reply. Although a transaction uses an IMS input and output message queue between the session and the application, these modes ensure that associated messages are always processed synchronously with relation to the source session. While these messages are being processed, IMS does not send asynchronous or unsolicited output on that session.

**Related Reading:** For more information on IMS message types and internal modes of execution, see *IMS Version 9: Administration Guide: System*.

Internal IMS definitions are either synchronous or asynchronous.

The following modes are synchronous:

- Response mode
- Conversational mode
- Fast Path
- Commands
- Test mode

The following modes are asynchronous:

- Nonresponse mode
- Nonconversational mode
- Message switch

### Resultant Processing Mode

During ISC communications, when the relationship between the externally requested execution mode and the internally understood processing mode are consistent, the message is processed exactly as requested. In the case in which the two specifications (internal versus external) are not consistent, the message's execution with respect to the session is synchronous.

In either case, if the generated reply is returned on the same session as the request, it is sent using the same type of FM headers that were received with the input message. If the reply is returned on a session other than the one on which the input message was received, it is considered unsolicited asynchronous output and is sent with the SCHEDULER FM header. If the subsystem that is to receive the reply does not support receipt of the SCHEDULER header, the reply is sent with an ATTACH header that terminates the bracket at the end of the IMS message. Therefore, with the exception of a nonlast conversation, nonlast MFS demand-paged messages, or test mode output, ATTACH is used instead of ATTACH SCHEDULER and EB is indicated on the first or only chain of the message. A Nonlast conversation, nonlast MFS demand-paged messages, and test mode output are sent carrying ATTACH with CD indicated on the first or only chain of the message.

However, when a message is sent from the front-end subsystem to the back-end subsystem that is externally requesting synchronous processing, no assumptions should be made by the front-end subsystem as to the timing of the output reply or the availability of any other output for that session. As a result, requests and

## Relationship of ISC and IMS Execution Modes

replies cannot be correlated within the front-end subsystem, even though execution in the back-end subsystem might have been synchronous. This is summarized in Table 24.

The special support for front-end and back-end system utilization Front-End Switch exit routine provides.

**Related Reading:** For more information on the Front-End Switch exit routine, see *IMS Version 9: Customization Guide*.

Table 24. Internal versus External Execution Mode Specification

Internal Specification (System Definition)	External Specification (FMH)	
	Synchronous <sup>1</sup>	Asynchronous <sup>2</sup>
Synchronous	Synchronous	Asynchronous <sup>3</sup>
Asynchronous	Synchronous <sup>4,5</sup>	Asynchronous

**Notes:**

1. Synchronous specification does not include ATTACH with EB indicated on the first or only chain of the message.
2. Asynchronous specification includes ATTACH with EB indicated on the first or only chain of the message.
3. Synchronous operation in IMS is allowed in this case, because the SNA-defined external asynchronous format allows IMS as the message receiver to execute an inbound message according to its own interpretation. Thus, IMS's internally synchronous definition overrides the external asynchronous format. If, however, IMS's internal (system definition) mode of execution is synchronous and the message is received with ATTACH EB, IMS generates an error message and terminates the session.
4. This support allows response mode to be established dynamically (on a message-by-message basis), even though the message was internally defined to be asynchronous (nonresponse mode).
5. Messages cannot be externally defined as synchronous when OPTIONS=NORESP is specified internally on the IMS TERMINAL macro or ETO user descriptors. This conflict between system definition and FM header intent causes session termination.

Traffic between two IMS systems is always sent in asynchronous format. If the internal definition of the transaction within the back-end system is synchronous, it is processed synchronously and the ISC session is held for synchronous output. However, this same relationship does not apply for the source terminal. The front-end IMS does not hold that terminal in response mode until the reply is received from the back-end subsystem, unless you are using the Front-End Switch exit routine.

**Related Reading:** For more information on the Front-End Switch exit routine, see *IMS Version 9: Customization Guide*.

## LTERM Users (Subpools) and Components

**Definition:** *IMS user blocks* are sets of IMS logical terminals (LTERMs) defined by the SUBPOOL macro during IMS system definition or dynamically created from ETO user descriptors. Subpools defined at system definition cannot be used with ETO LU 6.1 terminals. Users (subpools) defined for ISC are separate from the users defined for dial-type terminals and are permitted only in conjunction with ISC parallel session support.



## Relationship of ISC and IMS Execution Modes

**Definition:** The collection of all static ISC users is known as the *VTAMPOOL*. LTERMs defined within the *VTAMPOOL* are reassignable only between users within the *VTAMPOOL*. LTERMs not defined within the *VTAMPOOL* cannot be assigned into the *VTAMPOOL*.

ISC users are dynamically assigned to an ISC session instance as a result of session initiation. That is, these parameters define the user that is available to the given session instance. This user remains allocated to the named parallel session instance even across session and subsystem failures until released through normal termination by mutual agreement of IMS and the other subsystem. For a single nonparallel session, the allocation of a set of LTERMs is fixed during system definition.

**Related Reading:** For information on system definition for single and parallel sessions, see *IMS Version 9: Installation Volume 2: System Definition and Tailoring*.

Each IMS LTERM is associated with one input and one output IMS component. The input and output components can be the same component, or different components can be specified. Conversely, IMS does not prevent multiple input or output LTERMs from being associated with a single component. However, doing so can cause problems with input component determination or output presentation.

IMS uses the input component ID to identify the LTERM that is to be associated with the input message. For other terminal support, IMS assumes that all input is from the first LTERM in the list that passes the necessary operational and security checks. However, for input from an ISC node, the input component is determined based on the component that is indicated in the ATTACH FM header. If no FM header is received, IMS assumes the input is to be associated with the LTERM for input component (ICOMPT) one. After the component value is determined, if the associated LTERM cannot be found, is stopped, or is not ready, or if that LTERM cannot pass security checks, the message is rejected.

When output is sent, it is sent to the component (COMPT) identified with the output LTERM. Message switches, broadcast messages for specific LTERMs, and data replies from transactions are directed to the component that is associated with the specified output LTERM. The user-written MPP can insert to the I/O PCB and default to the output component that is associated with the selected input LTERM. It can also address specific components through the appropriate LTERM name by an insert to an alternate PCB.

You can establish proper relationships between input and output components through the NAME macro during IMS system definition or LTERM keyword on the ETO user descriptor. This enables a logical unit to indicate its input component and causes output to be returned to the associated output component that was indicated during IMS system definition or on an ETO user descriptor. Proper definition and use of components can reduce or eliminate the need for LTERM naming conventions, DL/I CHNG calls, and inserts to alternate PCBs.

**Recommendation:** Incorrectly specifying the message delete system definition parameter, *MSGDEL*, or the ETO user descriptor while defining ISC users (subpools) can prevent a session from being initiated. An ISC session can be initiated only if the *MSGDEL* specifications on the *TERMINAL* or ETO user descriptor and *SUBPOOL* macros match.

## Relationship of ISC and IMS Execution Modes

**Related Reading:** For more information on the TERMINAL macro statement, the SUBPOOL macro, and ETO user descriptor information, see *IMS Version 9: Installation Volume 2: System Definition and Tailoring*.

Also, when using the ISC message switch support or an alternate PCB insert from a local transaction in order to route messages to another subsystem and return replies to a source terminal operator, MSGDEL=SYSINFO must be specified on the IMS system definition TERMINAL macro or ETO logon descriptor associated with both the ISC session and the source terminal. Specifying MSGDEL=NONIOPCB for the ISC session prevents ISC-message routing to other subsystems. Specifying MSGDEL=NONIOPCB for the source terminal prevents message replies from being routed to the source terminal operator.

**Related Reading:** For more information on using an ISC message switch or an alternate PCB insert from a local transaction to route messages, see "IMS Use of Routing Parameters" on page 281.

The output bracket and send and receive protocols used by IMS depend on a combination of the system definition output component specifications, the protocol used to input the message to IMS, and the type of IMS message received. For example, IMS synchronous message types have a predefined protocol for output replies. Associated with the output component is a definition of send and receive protocols for asynchronous output.

**Related Reading:** For more information on the IMS output bracket protocol, see "Bracket Protocol for IMS Output" on page 333.

---

## Chapter 15. Designing Communications Using the ISC Protocol

This chapter is an overview of the topics that help you to design subsystem-to-subsystem communications that use the ISC protocol.

### In this Chapter:

- “Determining Output Protocols”
- “Accessing Existing Application Programs with ISC” on page 278
- “Statically Defining an ISC Node to IMS” on page 291
- “Choosing Parameters: System Design Considerations” on page 293
- “System Definition Summary” on page 296

---

### Determining Output Protocols

Traffic on the ISC session is controlled by the VTAM protocols associated with the message. The primary bracket protocols used are:

- Begin bracket (BB)  
Signals the beginning of a bracket. Begin-bracket is an unconditional request when issued by the first speaker (secondary half session) and a conditional request when issued by the bidder (primary half session).
- End bracket (EB)  
Signals the end of a bracket, places the session in contention state, and allows either session partner to request a new bracket.
- Change-direction (CD)  
Turns control of the session over to the session partner and allows the session partner to send traffic on the session.

Traffic across an ISC session can be sent and received synchronously to the session. The processing of messages is performed either synchronously or asynchronously to the session. That is, the sending subsystem initiates a message and waits for a reply (synchronous) or does not wait (asynchronous).

**Related Reading:** For more information on synchronous and asynchronous processing, see “Relationship of ISC and IMS Execution Modes” on page 272.

Within ISC, the external synchronous mode of operation (as specified by FM headers) requires transmitted messages and associated replies, if applicable, to occur within a single bracket. The end of synchronous mode is signaled by EB. When in synchronous mode, IMS must be able to reply, if required, within the same bracket (before EB is received) to any outstanding message traffic with the exception of a message switch. If the input message protocol prohibits IMS from sending any required replies within the same bracket, the input message is rejected.

Within IMS, the protocols used for output that must be sent with ATTACH (because the other subsystem lacks SCHEDULER support) are predefined, regardless of whether the originating input transaction and resulting output replies are synchronous (ATTACH) or asynchronous (SCHEDULER). This output includes:

## Determining Output Protocols

- Nonlast chains (pages) of MFS paged output
- The last (MFS paged) or only chain of response mode, conversation mode, test mode, and IMS command replies
- Asynchronous output

**Related Reading:** For more information on these predefined bracket and send/receive protocols, see “Bracket and Half-Duplex Protocol” on page 330.

You must define to IMS the protocols to be used with the last (MFS paged) or only chain of other asynchronous output. These are defined on the COMPTn keyword of the TERMINAL macro or on an ETO logon descriptor. Four parameters are supplied:

### **SINGLE1**

Asynchronous output for this component is sent one message per bracket.

### **SINGLE2**

Asynchronous output for this component is sent one message at a time with the VTAM begin-bracket (if necessary) and change-direction indicators to allow the receiving subsystem to optionally send its communication traffic.

### **MULT1**

All asynchronous messages for a given LTERM are sent before the bracket is ended.

### **MULT2**

All asynchronous messages for a given LTERM are sent before change-direction is sent.

**Related Reading:** For more information on these parameters, see “Bracket Protocol for IMS Output” on page 333.

For IMS-to-IMS sessions, the selection of SINGLE1, SINGLE2, MULT1, or MULT2 can be related to the transaction types and characteristics of the receiving IMS subsystem. The following considerations apply:

### **SINGLE1**

This protocol is appropriate for sending message switches, nonresponse transactions, or nonconversational transactions to the receiving IMS.

### **SINGLE2**

This protocol is appropriate for sending response mode (including Fast Path) transactions, commands, and test mode, because synchronous communication assumes that input generates corresponding output. Conversational mode is not supported on an IMS-to-IMS session.

### **MULT1 or MULT2**

These protocols treat asynchronous traffic the same way as SINGLE1 or SINGLE2 treat synchronous traffic. They are useful in suppressing contention when large amounts of asynchronous traffic are queued for transmission on one (MULT1) or both (MULT2) subsystems.

---

## Accessing Existing Application Programs with ISC

During an ISC session, you can access application programs written prior to your installation’s support of ISC. Consider the following information when planning to access these programs.

## Accessing Programs That Use MFS

If your application program uses MFS, is it sensitive to the MFS MODname? Your program is sensitive, for example, if the program tests the MODname in the IOPCB as part of its logic, or uses ISRT calls to the IOPCB that include a MODname as part of the call. If the program is sensitive, MFS must be used when input is received from an ISC session.

If your program is sensitive to cursor position, it cannot be used to receive ISC session input. An ISC LTERM is not a hardware device and, as a result, cursor position has no meaning.

For output, MFS provides support for attribute and extended attribute bytes.

**Related Reading:** For more information on support for attribute and extended attribute bytes for output, see the ATTR= keyword description of the DFLD statement for DPM-Bn in *IMS Version 9: Application Programming: Transaction Manager*.

ISC supports the system control area (SCA) and default system control area (DSCA) in the following manner. All functions allowed for the 3270 display can be specified by the application program in a message field (MFLD) defined as an SCA. A device field (DFLD statement) can be defined as an SCA in the device output format (DOF). For ISC subsystems, MFS does not interpret the SCA specifications; it merely relays them in the user-defined device field SCA that it sends to the remote program or ISC subsystem. The MFS-supported SCA, or DSCA, for ISC session output can be used by the receiving application program to intelligently handle a terminal device attached to its subsystem.

If your application program is not sensitive to MFS formatting, it is possible for an ISC-connected subsystem to send an input data stream to your program without invoking MFS. To accomplish this, the sending subsystem must construct an input data stream that is exactly the same as your program's I/O area. This "bypassing" of MFS would result in a reduction of the processor overhead associated with MFS. Bear in mind that bypassing MFS in this manner can result in the transmission of inefficient data streams from the sending subsystem and also makes the sending subsystem sensitive to changes in your program's I/O area.

It is probably easiest, from an implementation point of view, to use MFS with ISC when MFS is already used for input to your program. In this case, you simply create ISC (DPM-Bn) device input formats (DIF) and DOFs.

## Accessing Programs That Do Not Use MFS

The two input edit choices for existing application programs that do not use MFS are ISC edit and basic edit.

ISC Edit is the default edit process for ISC input to IMS. An existing application program expects the transaction code to be at the start of the input message and to be followed by a blank. When this is true, the sending subsystem should ensure that the transaction code is placed at the start of the data stream, followed by a blank. Password security is for statically defined terminals only and can only be invoked by placing the password after the transaction code in the data stream and ensuring that the SNA-defined PRN in the FM header is not present. When ISC Edit is used, the input data stream sent to IMS should match the application program's I/O area exactly.

## Accessing Existing Application Programs with ISC

Basic edit for ISC input provides standard editing as if the input comes from a terminal. It is used to edit device and operator control characters. The sending subsystem could simply pass through to IMS a data stream from a device that would normally use basic edit if it were attached directly to IMS. In this situation, IMS's ISC basic edit support eliminates application-provided editing in the sending subsystem. Basic edit is selected by the sending subsystem when it places the characters 'BASICEDT' in the DPN field of the FM header.

## Routing Messages

This topic introduces the routing fields in the SNA-defined FM headers and describes how IMS uses these fields to route messages (and thus support distributed processing).

### FM Headers for Message Routing

ISC message routing information is provided within SNA-defined function management (FM) headers. On input, IMS automatically processes the information in these FM headers and then removes them from the input message. IMS then passes the message to the appropriate input edit process. On output, IMS automatically builds the necessary routing FM headers based upon information provided by IMS system definition, session bind parameters, the input FM header, or MFS.

**Related Reading:** For more information on FM headers, see "Function Management Headers" on page 356.

For this explanation of distributed transaction processing, the portion of the ATTACH and SCHEDULER FM headers of interest are the routing parameters that they carry. Four fields (described more fully in "ATTDPN" on page 378 through "ATTDQN and ATTDPP" on page 381) are used to route messages to appropriate control blocks. These routing fields, present in both headers, are:

#### DPN (Destination Process Name)

The DPN parameter names an input process to be invoked synchronously to the session. Within IMS, the processes that can be invoked are basic edit, ISC edit, or MFS. For MFS, the input DPN value is the MFS message input descriptor (MID) name. For other subsystems, the named process can be the message destination (such as a transaction code).

#### PRN (Primary Resource Name)

The PRN parameter names a resource to be associated with the attached process. This parameter occurs on a reply returned as the result of processing a message in a remote subsystem.

Within IMS, the input PRN can name either an LTERM message queue for terminal output (IMS message switch) or an input transaction message queue. When the PRN is not available on input, IMS defaults to the normal method of using the message destination contained in the first data field (or optionally inserted by MFS formatting) or a preset transaction code established by an IMS operator command.

#### RDPN (Return Destination Process Name)

The RDPN parameter defines a suggested return destination process name to be associated with an output message. It should be returned as the DPN on resulting message replies to facilitate the processing of replies returned to the source subsystem. The input RDPN is discarded when replies or message switch output is sent on another session. The RDPN is sent by IMS only for MFS-formatted output, wherein the RDPN is the optional chained MID name specified on the MFS message output descriptor (MOD).

### RPRN (Return Primary Resource Name)

The RPRN parameter defines a suggested return primary resource name to be associated with an output message. It should be returned on resulting message replies to the subsystem that was the source of the message to facilitate return reply processing within that subsystem. The input RPRN is discarded when replies or message switch output is sent on another session. The RPRN can optionally be set by use of MFS formatted output if specified on the MFS MOD.

**Related Reading:** For a summary of IMS actions relative to the DPN, PRN, RDPN, and RPRN fields in the ATTACH and SCHEDULER FM headers, see Table 50 on page 381.

### IMS Use of Routing Parameters

IMS ISC without the Front-End Switch exit routine does not provide for automatic transaction routing when IMS is the front-end subsystem. These transactions can be sent as alternate PCB output from a user-written application program within IMS or by using an ISC message switch. In the latter case, the source terminal operator provides the output routing information through an ISC destination LTERM name which is the required first data field on IMS message switches.

Except when the output is formatted by MFS (by using a MOD chained from the input MID associated with the message switch), IMS message routing support for ISC removes the first data field before sending the balance of the message text to the back-end subsystem. When MFS is used to format message switch output, you should use MFS editing to remove the output LTERM name.

Further, ISC message routing support within IMS defaults the RPRN within the output FM header sent with the message to the LTERM name associated with the terminal that was the source of the message switch. For alternate PCB output, the RPRN is set to the I/O PCB name. The RPRN allows IMS to automatically route message replies from the remote subsystem back to the source terminal in the form of a message switch, provided the other subsystem has returned the RPRN parameter as the PRN parameter on the reply. MFS DPM can be used to alter the FM header destination and return routing parameters. When using IMS as a front-end subsystem to route messages to another subsystem or route replies back to the source terminal, MSGDEL=SYSINFO must be specified on the IMS system definition TERMINAL macro statement or an ETO user descriptor associated with both the ISC session and the source terminal.

### Routing Examples

The following routing examples show typical functions that can be accomplished between two subsystems using ISC and how routing parameters are used to accomplish these functions. In the examples:

- The ISC edit alias is ISCE.
- The LTERM name for input and output associated with the terminal on the left in the diagrams is T.
- The LTERM name for input and output associated with the terminal on the right in the diagrams is T2.
- The LTERM name for the ISC session between the two subsystems is LTISC1.

**Related Reading:** For an example of the Front-End Switch exit routine, see *IMS Version 9: Customization Guide*.

## Accessing Existing Application Programs with ISC

**Example 1. IMS-to-IMS Message Switch Routing:** Figure 45 shows the terminal attached to IMSA uses the ISC message switch to input TRANX to be executed in IMSB.

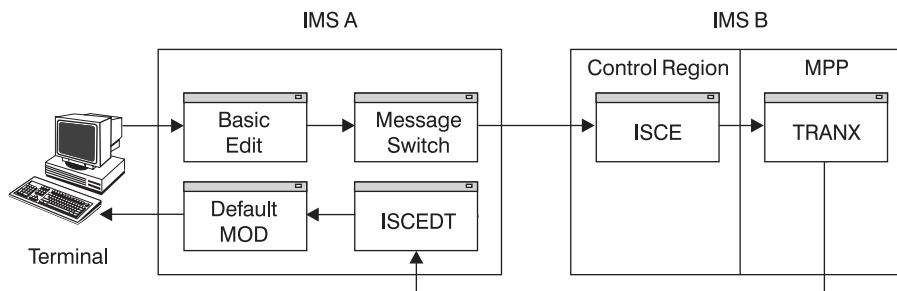

**Note to Figure:** The name ISCE was defined for ISC edit during system definition by specification of EDTNAME=ISCE on the COMM macro in both subsystems.

Figure 45. ISC Example 1. IMS-to-IMS Message Switch Routing

An MPP in IMSB processes TRANX, and the reply is routed back to the terminal in IMSA, which was the source of the message switch. The output terminal reply appears as an output message switch.

1. Assume the terminal is a 3270 display device. Based on this assumption, basic edit can only be invoked by entering input from a cleared screen. Therefore, in this example, the terminal operator enters:

```
LTISC1 | TRANX | Data...
```

LTISC1 is the IMSA logical terminal name associated with an ISC session between IMSA and IMSB.

2. Basic edit edits the input data stream from the terminal, and the message is placed on the IMSA message queue with a destination of LTISC1.
3. On output to LTISC1, ISC support in IMSA:
  - a. Strips the destination LTERM name (LTISC1) from the data stream
  - b. Builds the FMH required to send the transaction to IMSB
4. The data stream that is sent to IMSB looks like:

```
FMH: DPN=SCHEDULER
FMH: DPN=ISCE,PRN=,RDPN=,RPRN=T | TRANX | Data...
```

  - a. DPN=ISCE because IMS ISC support supplies this value as a default if no DPN is supplied when output is to be sent to another subsystem.
  - b. PRN= is not supplied and also not required for this example. TRANX is part of the user data. Only through the use of MFS can PRN= be supplied.
  - c. RDPN= is not supplied and also not required for this example. Only through the use of MFS can RDPN= be supplied.
  - d. RPRN=T is automatically inserted by IMSA as a default function of the message switching logic incorporated in IMS ISC.
5. The TRANX data stream is edited by ISC edit (ISCE) on input to IMSB, because the FMH specified DPN=ISCE. After editing, the data stream is placed on the message queues, and looks like:

```
TRANX | Data...
```
6. When scheduled, an MPP retrieves TRANX from the message queues and processes the transaction. Output inserted (ISRT) by the MPP to the originating input terminal looks like:



## Accessing Existing Application Programs with ISC

Data...

This output can be inserted (ISRT) by the MPP to its I/O PCB (on the same parallel session) or to an alternate PCB. The I/O PCB or an alternate response PCB must be used if TRANX is a response-mode transaction. An alternate PCB could be used if TRANX were a nonresponse transaction. Alternate PCB output is sent on the same or a different parallel session, depending on the session to which the output LTERM is assigned.

7. On output from IMSB to IMSA, the FMH is built and sent with the data:

```
FMH: DPN=SCHEDULER
```

```
FMH: DPN=ISCE,PRN=T,RDPN=,RPRN | Data...
```

The output is sent on the same session as that on which the input was received.

- a. DPN=ISCE is specified, because ISC support supplies this value as a default if no DPN is available from input, or through MFS when asynchronous output is to be sent to another system.
  - b. PRN=T is supplied, because the input FMH to IMSB specified RPRN=T. IMS ISC support automatically wraps an input FMH RPRN value to the output FMH PRN field.
  - c. RDPN= is not required but can be added by MFS DPM. The RPRN is not supplied, because the reply is returned on the same session as the input transaction. However, MFS can also be used to set the RPRN.
8. On input to IMSA, the reply from IMSB is edited by ISC edit (ISCE), because the FMH specified DPN=ISCE.

Because a PRN is supplied in an input FMH, ISC edit uses the PRN as the IMS destination and appends the PRN value to the input data. After ISC edit, the message is placed on the input message queues and looks like:

```
T | Data...
```

If MFS had been used to process the reply within IMSA, the insertion of the LTERM name can be suppressed. See Example 6.

9. An IMS default MOD is used to format the data for output to the terminal. The data displayed to terminal T is:

```
T | Data...
```

**Example 2. IMS-to-IMS Application Routing:** Figure 46 illustrates IMS-to-IMS routing using an application program in both IMS subsystems.

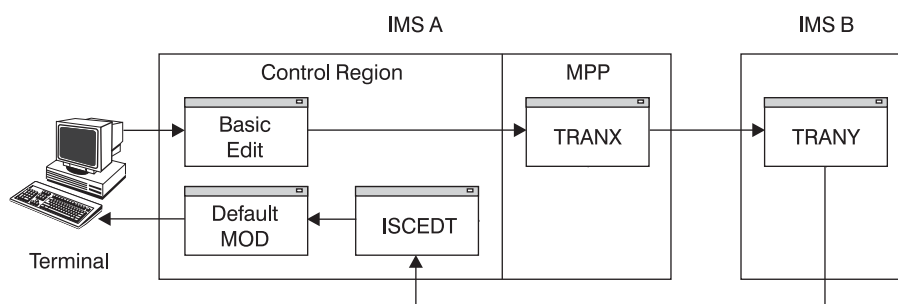

Figure 46. ISC Example 2. IMS-to-IMS Application Routing

The input format from the terminal operator differs from that in Example 1 in that the routing can be supplied by TRANX in IMSA rather than by the terminal operator. Processing in IMSB and on the session is the same as that described for Example 1. Also see Examples 6 and 7 later in this topic to understand the interaction of MFS in the routing scenario.

## Accessing Existing Application Programs with ISC

**Example 3. IMS-to-Other Subsystem Message Switch Routing:** The function to be accomplished with the example shown in Figure 47 is the same as that in Example 1. However, the back-end subsystem is either CICS or a user-written subsystem.

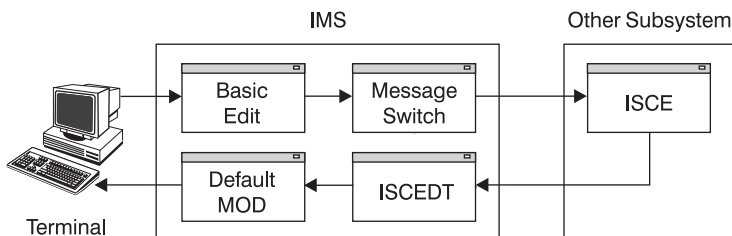

Figure 47. ISC Example 3. IMS-to-Other Subsystem Message Switch Routing

The description of the activities taking place in IMS for this example parallels that in Example 1. The “other” subsystem is of interest and is described below.

1. Assume the other subsystem is CICS. Remember, from Example 1, the data stream sent from IMS looks like this:

```
FMH: DPN=ISCE,PRN=,RDPN=,RPRN=T | Data...
```

The data is formatted in a way that ISCE expects to receive it. The IMS terminal operator who is entering the transaction should understand what that format is.

2. CICS must have a user-written transaction defined with transaction code ISCE, because the DPN represents a transaction code to CICS. CICS, after receiving the data stream described in item 1, invokes a transaction named ISCE, which must be specifically written for the ISC environment. This transaction examines the FMH values supplied and must use the RETRIEVE interface to obtain the user data and process TRANX.

Because CICS supports transaction codes having a maximum of 4 characters, ISC edit has been given the alias ISCE.

3. The output from the transaction in CICS must look like the output that IMSB sent back to IMSA in Example 1. That is:

```
FMH: DPN=ISCE,PRN=T,RDPN=,RPRN | Data...
```

The CICS transaction ISCE actually gives CICS the format to use to build the output FMH (in contrast to Example 1, wherein IMS ISC support builds the FMH). In this example, the CICS transaction must supply DPN=ISCE and PRN=T to CICS to enable the proper FMH to be built.

4. When IMS receives this output data stream from CICS, all activities parallel those in Example 1.

A user can implement the functions of this example in a user-written subsystem by understanding the previous explanation of CICS functions and relating it to the functions implemented in the system.

**Example 4. IMS-Terminal-to-IMS Terminal Message Switch Routing:** Figure 48 on page 285 shows a terminal T connected to IMSA effecting a message switch to terminal T2, which is connected to IMSB.

## Accessing Existing Application Programs with ISC

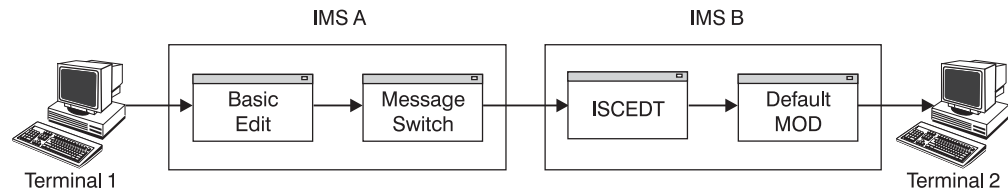

Figure 48. ISC Example 4. IMS-Terminal-to-IMS Terminal Message Switch Routing

1. The terminal T enters the following data stream:

```
LTISC1 | T2 | Data...
```

LTISC1 is an LTERM name that IMSA has associated with an ISC session to IMSB. The terminal operator (T) must know this ISC LTERM name as well as the LTERM name of the destination terminal (T2) attached to IMSB.

2. ISC message switch support removes the LTERM name (LTISC1) before sending the balance of the message on the ISC session to IMSB. Therefore, the data stream that is sent on the ISC session looks like:

```
FMH: DPN=SCHEDULER
```

```
FMH: DPN=ISCE,PRN=,RDPN=,RPRN=T | T2 | Data...
```

- a. DPN=ISCE is specified, because IMS ISC support supplies this value as a default if IMS does not supply a DPN when output is sent to another subsystem.
  - b. PRN= is not required, because the destination, terminal T2, is part of the data stream, but could be supplied or modified by MFS.
  - c. RDPN= is not supplied and is also not required for this example. This value could have been supplied by MFS.
  - d. RPRN=T, as in Example 1, is automatically inserted by IMSA as a default function of the message switching capability of IMS ISC. Because no reply is returned, this parameter is discarded by IMSB. MFS can be used in IMSB to make this parameter available to the operator of terminal T2.
3. Before the data stream is placed on IMSB's message queues, it is edited by ISC edit. In IMSB, ISC edit examines the data (because no PRN is available in the input FMH) to determine the destination. T2 is found to be the destination and the input message is placed on the message queues with a destination T2.
  4. On output from IMSB to terminal T2, the data stream now looks like this:  
T2 | Data...
  5. A default system MOD would be used for output if T2 were a required MFS device.

**Example 5. IMS-Terminal-to-Other Terminal Message Switch Routing:** Figure 49 is similar to Example 4; however, the back-end subsystem is CICS or a user-written subsystem.

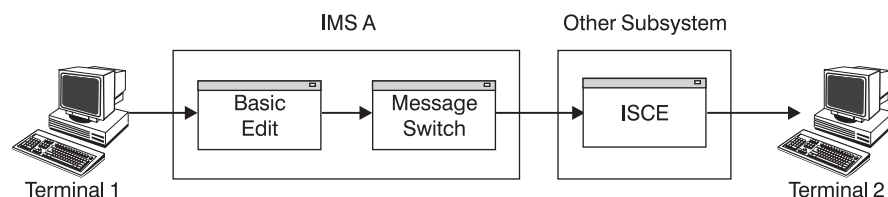

Figure 49. ISC Example 5. IMS-Terminal-to-Other Terminal Message Switch Routing

## Accessing Existing Application Programs with ISC

The description of the activities taking place in IMS in this example parallels the description in Example 1 exactly. The other subsystem is of interest is described.

1. Assume the other subsystem is CICS. Remember from Example 1 that the data stream sent from IMS looks like this:

```
FMH: DPN=ISCE,PRN=,RDPN=,RPRN=T | Data...
```

2. As in Example 3, CICS must have a transaction code defined as ISCE.

The data is formatted in the way in which ISCE expects to receive it. The IMS terminal operator who is entering the transaction should understand what that format is to be. CICS, upon receiving the data stream, must invoke a transaction named ISCE, specifically written for the ISC environment. This transaction uses the data in the input FMH and obtains the input data through the RETRIEVE interface. Because the PRN field in the input FMH is not initialized by IMSA to be equal to T2, the CICS application must initiate a message switch to terminal T2 from the transient data queue or start a new transaction naming T2 as the primary resource.

In this example, the output terminal T2 must be identified in the input data stream. If IMSA had initialized the PRN field in the input FMH to T2, CICS would have attached the transaction ISCE with T2 as the primary resource, and a SEND to terminal T2 could have been made directly.

3. In order for IMSA to set the PRN field, MFS would be required.

**Example 6. IMS-to-IMS Message Switch Routing with MFS:** In Figure 50, terminal T enters a transaction to be processed in the back-end IMS subsystem.

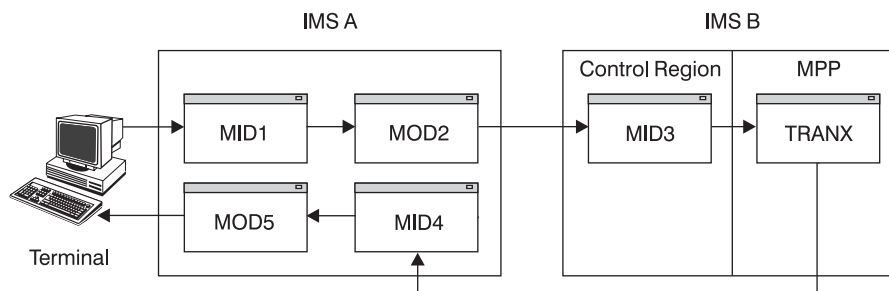

Figure 50. ISC Example 6. IMS-to-IMS Message Switch Routing with MFS

The reply from the back-end subsystem is to be routed back to the original terminal that entered the transaction (T).

1. Terminal T enters its input from a formatted screen. The terminal only needs to enter data.
2. After editing by MID1, the message is placed on the message queues and looks like this:

```
LTISC1 | TRANX | Data...
```

The values LTISC1 and TRANX were appended to the data by MFS.

3. MOD2, to be used for editing the data stream that is sent to IMSB, is chained from MID1, and is chained to another MID (MID4) within IMSA. The data stream to be sent to IMSB looks like this:

```
FMH: DPN=SCHEDULER
```

```
FMH: DPN=MID3,PRN=,RDPN=MID4,RPRN=T
```

```
TRANX | Data...
```

- a. DPN=MID3 can be supplied by MOD2 or from a literal in the DOF associated with MOD2.

## Accessing Existing Application Programs with ISC

- b. PRN= is not needed, because TRANX is already in the data stream. It could have been supplied from MOD2 or its associated DOF.
  - c. RDPN=MID4 is specified, because MID4 is chained to MOD2.
  - d. RPRN=T is again automatically inserted by IMSA as a default function of message switching and not overridden by MFS.
  - e. LTISC1 again has been stripped from the output message by the MFS MOD.
4. Upon receipt of the data stream from IMSA, IMSB edits the data using MID3, because the DPN in the FMH specified MID3.
  5. The application receives and processes the following:  
TRANX | Data...
  6. Output from the application program is sent by IMSB to IMSA in the following format:  
FMH: DPN=SCHEDULER  
FMH: DPN=MID4,PRN=T,RDPN=,RPRN= | Data...
  7. DPN=MID4 and PRN=T are automatically wrapped by IMS from the RDPN and RPRN values in the original FMH.
  8. On receipt of this data stream, MID4 in IMSA edits the input and places the message on the queues for final output to terminal T in the following format:  
Data...  
Because PRN=T is supplied, IMS uses it as the destination. Because MFS is also used to format the input reply, the PRN is not appended to the data.
  9. Because MOD5 is chained to MID4, MOD5 is used to format the output to terminal T.

Several observations can be made about this example:

- MID3 in IMSB is not chained to a MOD. Therefore, the I/O PCB that the application program in IMSB sees does not contain a MODname to be used for output. If MID3 should have a chained MOD, the application ISRT call should have a blank MOD name to negate MFS editing on output.
- The application in IMSB has not changed the MOD name for output. If it does, additional MFS format design is required.
- The MPP in IMSB can be an already-existing program that also handles transactions from terminals connected to IMSB. The use of MFS can make the use of an ISC session transparent to the application.
- The original input terminal is not held in response mode.

**Example 7. IMS-to-IMS Application Routing with MFS:** Figure 51 on page 288 can be understood in two contexts based upon an understanding of previous examples—the case shown in which ISC edit is used to edit the input in IMSB or the case in which MFS DPM-Bn is used to edit the input in IMSB.

## Accessing Existing Application Programs with ISC

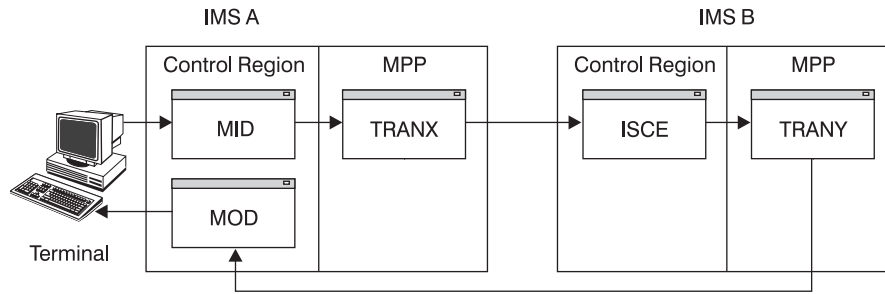

Figure 51. ISC Example 7. IMS-to-IMS Application Routing with MFS

Example 7 emphasizes several points:

- Terminal T is completely handled by the front-end subsystem. Therefore, in this example, Terminal T can be held in response mode with IMSA.
- The data sent from IMSA is inserted (ISRT) by an alternate PCB and is asynchronous to the response mode transaction.
- IMSA could be connected to many IMS subsystems and, based on the input transaction, route the ISC traffic to the appropriate back-end IMSB.
- The MPP in IMSA can provide any required message routing information, such as selecting the appropriate back-end subsystem through an ISRT to an alternate PCB.
- MFS can be used in either or both subsystems to provide data stream formatting and routing.

### Routing Messages through MSC to an ISC LTERM

You can route messages across an MSC link to an ISC half session. Suppose you have a setup similar to Figure 52. IMS A and IMS B connected by an MSC link. SYS C is connected to IMS B with an ISC link. If you want to route input messages and output replies between IMS A and SYS C, place the ISC routing parameters in the IMS prefix portion of the message. The MSC link-processing preserves these routing parameters.

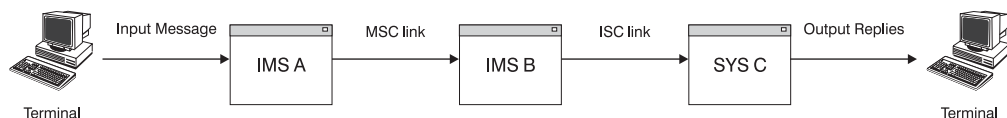

Figure 52. Routing of MSC to an ISC LTERM

## Considerations for IMS-to-IMS ISC Sessions

Consider the following information before configuring an ISC session between two IMS subsystems using static terminals.

### Coexistence of ISC and MSC VTAM within One IMS Subsystem

During IMS system definition, the TERMINAL, the MSPLINK macro statement, or an ETO logon descriptor of one IMS subsystem must be defined with the same name as that defined on the COMM (ACB name) macro of the other IMS system.

IMS system definition allows both the MSPLINK and TERMINAL macros or an ETO logon descriptor to indicate the same remote subsystem name. However, the session qualifier information (the name used on the SUBPOOL macro and the partner-id parameter on the MSPLINK macro) must be unique. This allows MSC and ISC sessions to be defined and simultaneously active between two IMS subsystems. The number of ISC parallel sessions that can be active simultaneously

between two IMS subsystems is the smaller of the values defined for the SESSION= parameter of the TERMINAL macro statements of the two IMS subsystems. (The SESSION= parameter is for statically defined terminals only.) The number of MSC parallel sessions that can be active simultaneously between two IMS subsystems is the smaller of the values defined for the SESSION= parameter of the MSPLINK macros of the two IMS subsystems. The total number of MSC and ISC parallel sessions that can be simultaneously active is the sum of these two smaller numbers.

### Defining Single and Parallel Sessions

During IMS system definition, the TERMINAL macro statements or the ETO logon descriptors defining the ISC session(s) between the IMS subsystems must be defined identically as either single session or parallel sessions. However, when both subsystems are defined for parallel sessions, the number of concurrently active sessions or number of SUBPOOL macro statements need not be identical.

Without ETO, you can define up to 4,095 parallel sessions. With ETO, the number of ISC parallel sessions is limited primarily by the processor capacity and the amount of virtual storage above and below the line available to the control region.

### Ensuring Compatible Buffer Sizes

The VTAM output buffer size defined on the TERMINAL macro statement or an ETO logon descriptor of one IMS subsystem must be compatible with the “receive-any” buffer size defined on the COMM macro statement of the other subsystem.

### Remote Control of IMS through ISC

The IMS ISC message switch support, user-written applications, or appropriate Security Maintenance Utility (SMU) specifications allow a terminal operator within one IMS subsystem to effectively control the operation of another IMS subsystem. The IMS automated operator interface (AOI) facility can also be used to aid in the control of either IMS subsystem.

For statically defined terminals, you can authorize commands or transactions to ISC sessions within the remote IMS subsystem; all terminal operators and application programs within the local IMS subsystem that are authorized to send data on the ISC session can then access the remote subsystem. Therefore, use password security to restrict remote subsystem access to only specific authorized individuals and applications as a master terminal within the IMS subsystem.

You can provide additional security by specifying that all commands on the ISC session be issued between automated operator interfaces in both subsystems or issued to a single automated operator interface in the back-end subsystem.

A logical unit type 6.1 cannot be defined as the IMS master terminal during IMS system definition, nor can it be assigned as a master terminal using the IMS /ASSIGN command.

### Restriction on IMS-to-IMS Conversation Mode

Conversation mode between two IMS subsystems is not supported. This is because conversations between IMS subsystems that are connected using ISC produce unpredictable session protocols and conversational transaction input when only one half session is in conversation mode. Further, the conversation terminates if both half sessions are in conversation mode.

### Routing Transactions to the Back-End IMS

IMS ISC support allows the following to route transactions to a back-end IMS subsystem:

- Terminal operators using ISC message switches.
- Application programs using alternate PCB inserts within the front-end IMS subsystem.

In either case, the default action by the ISC support is to route a resulting transaction reply, in the form of a message switch, back to the originating terminal operator or transaction. Under these conditions, the transactions accessed within the back-end IMS subsystem should generally be defined as recoverable, because the response required for the message switch reply is also recoverable.

Irrecoverable transactions can be accessed, but require the use of MFS DPM-Bn to change the default destination set in the ISC message routing parameters from the LTERM associated with the originating terminal operator to an irrecoverable transaction within the front-end IMS. This avoids the protocol errors that occur when sending irrecoverable reply messages. The destination can be changed by MFS DPM either within the front-end IMS to modify or delete the default RPRN parameter sent on the transaction to the back-end IMS, or within the back-end IMS to modify or delete the wrapped PRN parameter sent on the reply to the front-end IMS. This irrecoverable transaction can then route the reply to the appropriate terminal operator by inserting to a modifiable alternate PCB.

Special support exists for front-end/back-end system utilization provided by the Front-End Switch exit routine.

**Related Reading:** For more information on the Front-End Switch exit routine, see *IMS Version 9: Customization Guide*.

### Sending Messages between the Subsystems

Communication from an IMS front-end is always asynchronous. Therefore, messages are required to be sent and received with both the ATTACH and SCHEDULER FM headers. The exception to this is that system messages are sent with the ATTACH FM header only.

**Related Reading:** For more information on the system message process, see "System Message Process (SYSMSG) and Related FM Headers" on page 361.

### Protocol Restrictions on IMS-to-IMS Sessions

When an ISC session is between two IMS subsystems, certain types of protocols are not sent between the subsystems. This subtopic provides these protocols. If you are designing IMS-to-IMS sessions, you can skip the information on these protocols and headers provided in Chapter 16, "ISC Protocol Guide and Reference," on page 299.

- The data flow control commands BID, RTR, and RSHUT are not sent between the two IMS subsystems.
- The reset-attached process (RAP) FM header is not sent between IMS subsystems.
- The queue model (QMODEL) headers are not sent between IMS subsystems. This precludes IMS output demand-paging and all associated input QMODEL paging requests. Also, the ATTDQN parameter on the ATTACH FM header and the SCDDQN parameter on the SCHEDULER FM header are not supported in IMS-to-IMS sessions.



- The following error codes are not sent between two IMS subsystems:
  - LUSTATUS commit and function abort X'0864' and X'0866'
  - All sender ERP sense codes except X'0813' and X'0846'
  - Selective receiver ERP sense codes, except as listed under “Selective Receiver ERP” on page 347.

---

### Statically Defining an ISC Node to IMS

A subsystem that is statically defined at system definition to IMS as an ISC node appears to IMS to be a terminal and to an IMS application program to be one or more logical terminals (LTERMs). Thus, an ISC node is defined using those system definition macros applicable to defining other VTAM terminals.

Table 25 shows the macro statements that define an ISC node.

*Table 25. Macro Statements For Defining an ISC Node*

Macro Statement	Use
COMM macro	Names the IMS subsystem to VTAM; names the ISC edit process and defines the receive-any (RECANY) buffer size.
TYPE macro	Identifies the unit type as an ISC node (UNITYPE=LUTYPE6).
TERMINAL macro	Identifies the other ISC node to IMS. Also provides sizes for the output and Fast Path buffers, limits for the input segment size, and processing options. Defines the number of sessions possible between two ISC nodes. Describes component characteristics.
VTAMPOOL macro	Begins the definition of the ISC LTERM users (subpools) used with parallel sessions.
SUBPOOL macro	Defines a set of LTERMs within the VTAMPOOL.
NAME macro	Names the LTERMs associated with a given terminal for a single session or a given user (subpool) for parallel sessions.

**Related Reading:** For more information on these system definition macros, see *IMS Version 9: Installation Volume 2: System Definition and Tailoring*.

This topic more fully describes the macros that are key to defining an ISC session between two systems and some of the implications of selecting certain system definition options instead of others.

Figure 53 on page 292 shows two IMSs, NYIMS in a New York data center and SFIMS in a San Francisco data center. NYIMS and SFIMS are each defined to the other as an ISC node. The following paragraphs details the way in which these IMSs would be defined during IMS system definition. For ease of understanding, this description focuses on defining the IMS SFIMS to the IMS NYIMS. A similar system definition would be required to define IMS NYIMS to IMS SFIMS. Only those parameters of interest on the COMM, TERMINAL, and NAME macro statements are described.

## Statically Defining an ISC Node to IMS

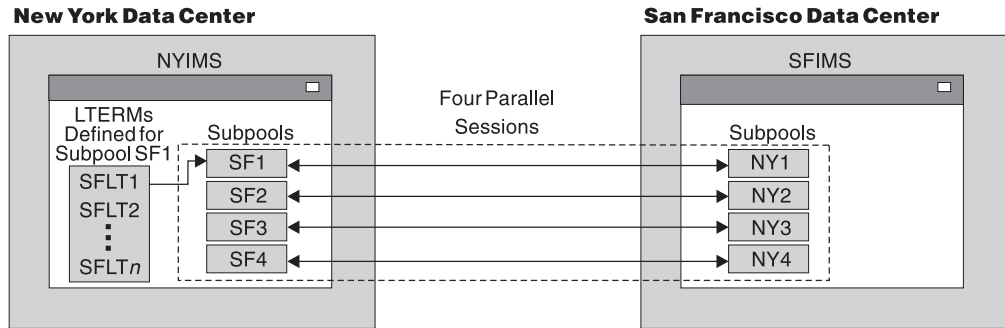

Figure 53. Two IMSs Defined to Each Other as ISC Nodes

The parameter APPLID=NYIMS on the NYIMS system definition COMM macro makes that subsystem known by the node name NYIMS to VTAM, to itself, and to any other subsystems that need to access it. A similar system definition must occur for the San Francisco IMS SFIMS.

NAME=*nodename* on the TERMINAL macro statement of the NYIMS system definition is coded to show the node name of the SFIMS system (NAME=SFIMS). If SFIMS is an XRF complex, the node name should be the USERVAR or MNPS ACB associated with the SFIMS system.

The SESSION= keyword is related to parallel sessions rather than to a single session. (The SESSION= keyword applies to statically defined terminals only. It does not apply to the ETO environment.) SESSION= specifies the maximum number of parallel sessions that are allowed from NYIMS to SFIMS. It is possible to code one “parallel” session. A single session and one parallel session are not the same.

**Related Reading:** For more information on single and parallel sessions, see “LTERM Users (Subpools) and Components” on page 274.

By coding SESSION= as greater than one, the NYIMS might maintain multiple concurrent sessions with SFIMS, up to the number specified by the SESSION= parameter. In Figure 53, four paths are drawn between the two IMS systems. Each path represents a parallel session. To allow four parallel sessions in the NYIMS, code SESSION=4.

A major advantage of parallel session support is the ability to dynamically allocate LTERMs to that session based on the IMS /OPNDST command parameters.

**Related Reading:** For more information on dynamic LTERM allocation, see “LTERM Users (Subpools) and Components” on page 274.

Each parallel session is required to be identified to NYIMS using the SUBPOOL macro statement. In the example, to allow four concurrently active parallel sessions, four users (subpools) must be defined as follows in the NYIMS system definition:

```
VTAMPOOL
  SUBPOOL  NAME=SF1
  SUBPOOL  NAME=SF2
  SUBPOOL  NAME=SF3
  SUBPOOL  NAME=SF4
```

The VTAMPOOL macro statement begins the definition of the ISC subpools and must be coded if parallel sessions are to be used. The VTAMPOOL macro statement has no operands.

In Figure 53 on page 292 SFLT1, SFLT2, SFLT3,...SFLTn represent LTERM names that have been defined to the first SUBPOOL, SF1. The definition of LTERMs within a given subpool is accomplished by coding the NAME macro. Defining multiple LTERMs to a subpool provides several advantages. The first is that an LTERM or LTERMs defined to a given subpool can be reassigned (using the /ASSIGN command) to any other subpool. This capability gives flexibility in the operation of an ISC network.

The second advantage is with the COMPTn= keyword on the TERMINAL macro statement. This keyword can be used to define or assign certain characteristics to a given LTERM. COMPT= and ICOMPT= are the keywords on the NAME macro statement and are used to associate a component (COMPTn) with an LTERM.

The definition of SFIMS to NYIMS now looks like Figure 54:

```
TYPE          UNITYPE=LUTYPE6
TERMINAL NAME=SFIMS
              SESSION=4

VTAMPOOL
  SUBPOOL NAME=SF1
          NAME SF1LT1
          NAME SF1LT2
  :
          NAME SF1LTN
  SUBPOOL NAME=SF2
  :
  SUBPOOL NAME=SF3
  :
  SUBPOOL NAME=SF4
  :
```

Figure 54. The Definition for SFIMS and NYIMS

---

## Choosing Parameters: System Design Considerations

This topic further describes the parameters of the COMM, TERMINAL, NAME, and SUBPOOL macro statements.

### COMM Macro Statement

The key parameters on the COMM macro statement are as follows:

- APPLID
- RECANY
- EDTNAME

The APPLID parameter defines the VTAM ACB name for IMS. The name specified for APPLID= must be the same as the ACBNAME= parameter of the VTAM APPL definition statement. If the ACBNAME= parameter is not specified, the APPLID= name must be the same as the name of the APPL definition statement that is used when defining IMS to VTAM. If the other subsystem is also an IMS, the name

## Choosing Parameters: System Design Considerations

specified for APPLID= must be the same as that supplied on the NAME= keyword parameter of that IMS TERMINAL macro statement.

If you choose not to define the APPLID parameter on the COMM macro statement and instead use the JOBSTEP name of the EXEC statement when initiating the IMS control region, VTAM attempts to match that name with either the ACBNAME= parameter or the name of the VTAM APPL definition statement, as described in the preceding paragraph.

When specifying the receive-any (RECANY) buffer size on the COMM macro, remember that a 28-byte overhead applies to the size of the receive buffers for ISC sessions. Therefore, the RECANY buffer size specified on the NYIMS system definition must be at least 28 bytes larger than the size specified for OUTBUF= on the TERMINAL macro of the SFIMS system definition for NYIMS. When defining SFIMS, the same considerations apply.

Other factors affect the size of the RECANY buffers. Because the specified RECANY buffer size applies to all VTAM devices, the size specified for RECANY might be larger than the size required for ISC due to the needs of other VTAM devices. Also, the FM header size must be added to the maximum data record size for both systems to determine the maximum ISC RECANY size.

The EDTNAME parameter specifies the alias that can be used for ISCEDT in your IMS system. In this system definition, the default name, ISCEDT, is used, making the specification of the EDTNAME= parameter unnecessary.

### Related Reading:

- For information on the interaction of the receive-any buffer size and the output buffer size, see “Specifying the OUTBUF= Keyword Parameter” on page 295.
- For more information on setting buffer sizes, see *IMS Version 9: Installation Volume 2: System Definition and Tailoring*.

## NAME Macro

The key system definition options for defining an ISC session on the NAME macro are as follows:

- COMPT
- OUTPUT
- EDIT
- ICOMPT

COMPT= and ICOMPT= specify the output and input components respectively to be associated with the LTERM being defined. The system definition example uses components defined as COMPT=1 and COMPT=2.

OUTPUT= should not be used on an ISC session.

**Recommendation:** If you do not want translation of ISC output to the session, specify ULC. If session output can be uppercase or lowercase data, or binary data, use ULC.

## SUBPOOL Macro

The SUBPOOL macro identifies ISC subpools to a system. The key system definition options on the SUBPOOL macro are as follows:

- NAME
- MSGDEL

The NAME parameter identifies the ISC subpool.

In this example, the MSGDEL specification is the default, SYSINF0. When MSGDEL is specified on the SUBPOOL macro, it must match the MSGDEL specification on the TERMINAL macro.

**Related Reading:** For more information on specifying MSGDEL, see “LTERM Users (Subpools) and Components” on page 274.

### TERMINAL Macro

The principal system definition keyword parameters for defining an ISC session on the TERMINAL macro are as follows:

- OUTBUF
- MSGDEL
- COMPT1
- COMPT2
- COMPT3
- COMPT4

Additional parameters you must specify include:

- SINGLE or MULT
- VLVB or DPM-B1...DPM-B15

#### Specifying the OUTBUF= Keyword Parameter

IMS does not negotiate buffer sizes when initiating an ISC session, nor does IMS support RU truncation. When sending a negotiated bind, IMS sets its send (OUTBUF=) and receive (RECANY=) sizes in the bind.

When receiving the bind reply, IMS verifies that:

- Its send (OUTBUF=) size has not been reduced by the other subsystem.
- Its receive (RECANY=) size is not exceeded by the other subsystem’s send (OUTBUF=) size.

When receiving a negotiated bind, IMS:

- Verifies that the send (OUTBUF=) size of the other subsystem does not exceed IMS’s receive (RECANY=) size.
- Inserts the send (OUTBUF=) size into the bind reply.

The specified OUTBUF size must be large enough to include the largest output segment size plus the overhead for message headers. When defining the SFIMS system, the same considerations apply.

**Related Reading:** For more information on the RECANY buffer size, see “COMM Macro Statement” on page 293.

### Specifying the MSGDEL= Keyword Parameter

A description of the ramifications of choosing SYSINFO or NONIOPCB is found in “LTERM Users (Subpools) and Components” on page 274. In the example in that topic, the default for SYSINFO is used for both the TERMINAL and the SUBPOOL macros.

### Specifying the COMPTn= Keyword Parameter

Up to four components can be defined for a given ISC node on the TERMINAL macro by using the keyword parameters COMPT1= through COMPT4=. COMPTn= allows flexibility in assigning characteristics to LTERMs. In the system definition example, component 1 is specified as having the characteristics SINGLE1, DPM-B1, and IGNORE. Component 2 is specified as having the characteristics SINGLE2, DPM-B2, and IGNORE.

### Specifying the SINGLE or MULT Parameter

The characteristics of SINGLE1, SINGLE2, MULT1, and MULT2 are described in “Determining Output Protocols” on page 277.

### Specifying the VLVB or DPM-B1...DPM-B15 Parameter

Selecting VLVB or DPM-Bn determines whether the component can use the Distributed Presentation Management feature of MFS. Although MFS is specified for a component by specifying DPM-Bn, its use is optional, on a message-by-message basis. DPM-Bn is used for this system definition example.

The selection of VLVB precludes the use of MFS-DPM for a component and indicates that variable-length, variable-blocked format is to be used instead of MFS for both input and output.

**Related Reading:** For more information on VLVB, see *IMS Version 9: Application Programming: Transaction Manager*.

### Specifying the IGNORE or 1, 2,...10 Parameter

This parameter is used to specify a user-defined feature code for MFS DPM-Bn. The designated feature is used to select an MFS format (DPM-B1...DPM-B15) that contains the matching feature specification. IGNORE is used to specify that an MFS format (DPM-Bn) with the FEAT=IGNORE of the DEV statement is to be selected. IGNORE has been used for this system definition example.

---

## System Definition Summary

Referring back to our example in Figure 53 on page 292, SFIMS can be defined to NYIMS as shown in Figure 55 on page 297.

```

TYPE          UNITYPE=LUTYPE6
TERMINAL NAME=SFIMS
      COMPT1=(SINGLE1, DPM-B1, IGNORE)
      COMPT2=(SINGLE2, DPM-B2, IGNORE)
      SESSION=4
VTAMPOOL
SUBPOOL NAME=SF1
      NAME SF1LT1, COMPT=1
SUBPOOL NAME=SF2
      NAME SF2LT1, COMPT=2
SUBPOOL NAME=SF3
      NAME SF3LT1, COMPT=2
SUBPOOL NAME=SF4
      NAME SF4LT1, COMPT=2

```

Figure 55. SFIMS Defined to NYIMS

**Related Reading:** For more information on the parameters not described in this chapter, see *IMS Version 9: Installation Volume 2: System Definition and Tailoring*.

This definition does not correspond exactly to Figure 53 on page 292. In that figure, the SUBPOOL SF1 contains multiple LTERMs (to indicate that multiple LTERMs can be assigned to a SUBPOOL). Based on SINGLE1, SINGLE2, MULT1, and MULT2, the definition can now be simplified to show just one LTERM being defined per SUBPOOL.

The first SUBPOOL, SF1, has LTERM SF1LT1 defined with COMPT=SINGLE1. For asynchronous output from NYIMS to SFIMS, LTERM SF1LT1 is used as the destination LTERM for all:

- Alternate PCB output from application programs in NYIMS that generates asynchronous transactions in SFIMS
- Message switches originated by a terminal connected to NYIMS
- Replies to nonresponse transactions received by NYIMS from SFIMS

The characteristics of SINGLE1 (BB/message/EB) should allow one parallel session to handle all asynchronous input and output between NYIMS and SFIMS.

Three SUBPOOLS (SF2, SF3, SF4) have been defined with single LTERMs, each defined with a COMPT defined as SINGLE2. These three SUBPOOLS (sessions) can be used to send response mode transactions to SFIMS. Because of the nature of response mode transactions (session tied up from transaction origination until receipt of reply), three parallel sessions are defined to allow the user to minimize response mode bottlenecks between NYIMS and SFIMS.

In most IMS ISC definitions, the assignment of one LTERM to each SUBPOOL is sufficient to handle the communications traffic between the two nodes.

Not shown, but certainly to be considered, is the possibility of defining a fifth SUBPOOL within NYIMS to handle incoming SINGLE1 traffic from SFIMS. By design then, NYIMS could receive all SINGLE1 input from SFIMS on the session defined by the fifth SUBPOOL and send all SINGLE1 output on the session defined by the first SUBPOOL (SF1). This plan would result in minimal contention for asynchronous output between the two systems.

## System Definition Summary



---

## Chapter 16. ISC Protocol Guide and Reference

This chapter contains the protocols IMS uses to control sessions, data flow, and message routing. It has the specific protocol information you need to send and receive data with an ISC link.

### **In this Chapter:**

- “Operating the Network” on page 300
- “Controlling the Session (Session Control Protocols)” on page 301
- “Resynchronizing Sessions” on page 304
- “Completing Session Initiation” on page 312
- “Running the Session” on page 313
- “Terminating the Session” on page 313
- “Using STSN to Resynchronize Sessions” on page 314
- “STSN Command Format” on page 317
- “Handling IMS Response Mode or Conversational Output Errors” on page 319
- “Normal Conversation Termination Extension with ISC” on page 321
- “Keeping Half Sessions Synchronized” on page 321
- “Data Flow Control Protocol Reference” on page 329
  - “BID Protocol” on page 330
  - “Bracket and Half-Duplex Protocol” on page 330
  - “CANCEL Protocol” on page 338
  - “Chaining Protocol” on page 339
  - “CHASE Protocol” on page 339
  - “ERP Purging” on page 340
  - “LUSTATUS Protocol” on page 343
  - “Paged Messages ERP” on page 346
  - “Ready-to-Receive Protocol” on page 346
  - “RSHUT Protocol” on page 347
  - “Selective Receiver ERP” on page 347
  - “Sender ERP” on page 351
  - “Sense Codes that IMS Receives” on page 353
  - “Sense Codes that IMS Sends” on page 354
  - “SIGNAL Protocol” on page 355
  - “Symmetrical Session Shutdown for LU 6.1 (SBI and BIS)” on page 355
- “Function Management Headers” on page 356
  - “Using FM Headers to Invoke ISC Edit” on page 358
  - “Initiating a Process: ATTACH FM Header” on page 358
  - “Error Recovery Procedure FM Header” on page 359
  - “Resetting the Active Process: RAP FM Header” on page 359
  - “Requesting Asynchronous Transaction Processing: SCHEDULER FM Header” on page 360
  - “System Message Process (SYSMSG) and Related FM Headers” on page 361

### Operating the Network

Because ISC permits multiple sessions between logical units, the balance of this explanation of ISC differentiates between the terms logical unit, session, and half session:

**Definitions:**

- The term *logical unit* is used when referring to characteristics common to all sessions between two session partners or when it is not necessary to differentiate between individual sessions.
- The term *session* is used when describing a characteristic unique to a given connection (session instance) between logical units.
- A *half session* describes characteristics unique to one of the session partners.

### Making IMS Ready

Use the IMS /START command with the DC keyword to make IMS ready to receive VTAM logon or BIND SCIP (session initialization) requests. The DC keyword initiates IMS data communications processing, opens the VTAM access method control block (ACB) if it is not already open, and enables the IMS VTAM logon exit. Any logon requests received by VTAM before the IMS /START DC command is issued but after the ACB has been opened are queued in VTAM until the /START DC command is completed. If VTAM is active when IMS is initialized, and the DFSDCxxx PROCLIB member keyword VACBOPN=INIT, then the IMS VTAM ACB is opened. If DFSDCxxx PROCLIB member keyword VACBOPN=DELAY, then the IMS VTAM ACB open is delayed until the /START DC command is processed.

The /START DC command also tells VTAM to pass any queued VTAM logon requests to IMS.

### Bringing Up an IMS Network

Before any sessions can be established, VTAM and NCP must be active. In addition, all logical units must be online (activated by the VARY command).

**Related Reading:** For information on establishing individual sessions, see “Controlling the Session (Session Control Protocols)” on page 301.

You do not need to perform message resynchronization after a cold start.

**Related Reading:** For information on cold starting a network, see *IMS Version 9: Operations Guide*.

### Shutting Down an IMS Network

Use the IMS /CHECKPOINT command to terminate the network and shut down IMS. The format of the /CHECKPOINT command determines whether the network termination occurs immediately or waits for processing to complete:

- /CHECKPOINT FREEZE|DUMPQ|PURGE immediately terminates the session for all logical units, as follows:

<b>FREEZE</b>	Immediately after current input/output message
<b>DUMPQ</b>	After control blocks are past checkpoints
<b>PURGE</b>	After all queues are empty
- /CHECKPOINT FREEZE|DUMPQ|PURGE QUIESCE allows all network nodes to complete normal processing before shutting down.

The IMS command `/STOP DC` also shuts down an IMS network at completion of processing.

Also, certain VTAM commands, such as `VTAM HALT NET`, shut down the network.

**Related Reading:** For more information on shutting down an IMS network, see *IMS Version 9: Operations Guide*.

---

## Controlling the Session (Session Control Protocols)

Session initiation includes initiating a session instance, binding the session, and, if necessary, ensuring that the half sessions are in sync. When both half sessions have agreed to the bind and are in sync, normal traffic flow is initiated using the VTAM start data traffic (SDT) command.

### Initiating a Session

A session must be established before data can be transmitted between another logical unit type 6.1 and IMS. If message resynchronization is required, it is performed after the bind.

IMS can be requested to initiate a session in one of the following ways:

- An ISC logical unit requests session initiation by sending the “initiate-self” command. VTAM verifies the command and passes the request to IMS.
- An ISC logical unit sends `BIND` to initiate a session with IMS.
- The z/OS VTAM network operator requests session initiation on behalf of the logical unit by using the z/OS `VARY` command with the `LOGON` option. VTAM processes the request and passes it to IMS. The `VARY` command cannot be used to initiate parallel sessions.
- VTAM passes to IMS a `LOGON` or `BIND SCIP` request for each logical unit defined to VTAM as belonging to IMS. (This method cannot be used to initiate parallel sessions.)
- An authorized IMS terminal operator requests session initiation for an ISC logical unit by entering the `IMS /OPNDST` command.

IMS can initiate (send `BIND`) or accept (receive `BIND`) a session if all the following conditions are met:

- The IMS master terminal operator has issued a `/START DC` command.
- The logical unit name is known by IMS.
- The logical unit is not stopped (`/STOP` command) within IMS.
- The logical unit has not reached the maximum allowable sessions defined to IMS. (This applies to statically defined terminals only.)
- If the session is to be parallel, the `CINIT` or `BIND` session qualifier field must contain a valid `LTERM` subpool name that defines the message queue set to be used. A valid subpool name is one that is not stopped or allocated (except during session restart). The session qualifier fields must not be supplied when requesting session initiation with a logical unit defined to IMS as single session.
- For statically defined terminals, the `MSGDEL` option for the `LTERM` subpool as specified on the `SUBPOOL` macro does not conflict with the `MSGDEL` option specified for the session on the `TERMINAL` macro.

**Related Reading:** For more information on specifying the appropriate parameters, see the descriptions of these macros in “Statically Defining an ISC Node to IMS” on page 291.

## Controlling the Session (Session Control Protocols)

- No invalid or conflicting parameters are indicated on either a CINIT, BIND, or negotiable BIND reply.

**Related Reading:** For information on the ISC bind parameters, see Appendix B, "Bind Parameters for SLU P and LU 6.1," on page 503.

### Establishing a Connection with an XRF Complex

An XRF complex can be a session partner. There are two types of XRF complexes: those that use a USERVAR to manage sessions during an XRF takeover and those that use an MNPS ACB to manage sessions during an XRF takeover.

In either case, if the active IMS subsystem in the XRF complex fails, the alternate IMS subsystem re-establishes the session during takeover. Until the ISC session between the old active IMS and the remote system terminates completely, session initiation fails. Upon takeover, the alternate IMS subsystem becomes the active subsystem and retries session initiation every 30 seconds (for a maximum of 20 attempts) until the session initiates successfully.

#### Connecting to an XRF Complex that Uses an MNPS ACB

To establish a connection with a session partner that is an XRF complex that uses an MNPS ACB, simply initiate the session with the XRF complex by specifying the MNPS ACB name as you would to connect to any other non-XRF IMS system.

#### Connecting to an XRF Complex that Uses a USERVAR

To establish a connection with a session partner that is an XRF complex that uses a USERVAR, you must take the following actions at ISC session initiation:

- If the non-XRF half session initiates the session with IMS, the non-XRF half session should:
  1. Identify the APPLID of the currently active IMS system by issuing the following macro:

```
INQUIRE OPTCD=USERVAR,AREA=area,AREALN=8
```

If the VTAM network is Release 3.2 or later and USERVAR Management Enhancement is installed, you do not need to issue the INQUIRE macro. With this request, the AREA parameter specifies the address of the area with the USERVAR name for the active XRF system. The USERVAR is then replaced with the APPLID of the currently active IMS system.
  2. Issue a session-initiation request by specifying the APPLID of the active IMS system.

If the VTAM network is Release 3.2 or later and USERVAR Management Enhancement is installed, issue a session-initiation request by specifying the USERVAR of the XRF system.
- If the IMS system in the XRF complex initiates the session, the IMS system:
  1. Issues the session-initiation request, adding the USERVAR assigned to the BIND in the user data field.
  2. Validates the session-initiation request by referencing the USERVAR in the user data field located at the end of the request. Initiation is not apparent to the user.

### Binding the Session

In an ISC session, IMS can assume either the primary half-session role (send the BIND) or the secondary half-session role (receive the BIND). However, when session restart and recovery are required, session polarity must be maintained.

**Definition:** *Session polarity* means that the same session role (primary versus secondary) is in effect at the point of failure and is reestablished by the session initiation request. Otherwise, the request is rejected. When the session is initiated using an IMS /OPNDST command and session restart and recovery are not required, IMS requests to be the primary half session.

### Negotiable versus Nonnegotiable BIND

As the primary half session, IMS sends either a negotiable or nonnegotiable BIND, depending on parameters in the VTAM mode table. The mode table entry is indicated on the VTAM CINIT or IMS /OPNDST commands, or defined on the TERMINAL macro during IMS system definition.

#### Definitions:

- When sending a *negotiable BIND*, IMS sets the bind parameters, as indicated in Appendix B, “Bind Parameters for SLU P and LU 6.1,” on page 503. Because the secondary half session can change some parameters, all the parameters are checked for validity by IMS when a negotiable BIND response is received.
- Prior to sending a *nonnegotiable BIND*, IMS checks all parameters from the mode table entry for validity. The session is terminated if IMS finds any incompatible parameters.

**Related Reading:** For information on the parameters that can be set in the mode table entries or changed on a negotiable BIND response, see Appendix B, “Bind Parameters for SLU P and LU 6.1,” on page 503.

As the secondary half session, IMS receives both the negotiable and the nonnegotiable form of BIND. When receiving a negotiable BIND, IMS checks the bind parameters, except the secondary network addressable unit (NAU) protocol field, for validity. IMS then sets the secondary NAU protocol field for the negotiable BIND response to the values indicated in Appendix B, “Bind Parameters for SLU P and LU 6.1,” on page 503.

When receiving a nonnegotiable BIND, IMS checks the bind parameters, except for “STSN required” and “BIS sent,” for validity prior to accepting the BIND. IMS must then operate under the secondary NAU protocol definition provided in the bind.

### Binding Single or Parallel Sessions

Requirements for binding a session differ for single and parallel sessions. To bind a single session, either negotiable or Nonnegotiable BIND is sent. The ISC logical unit with which IMS is communicating must have been defined with a static set of LTERMs during IMS system definition. IMS ignores the session qualifier pair (SQP) field on both CINIT and BIND.

To bind a parallel session, the CINIT and BIND parameters must include a SQP field to identify the specific parallel half-session instance between IMS and a logical unit. (All sessions created dynamically using the ETO feature are parallel sessions.) This field in the bind parameters contains both the primary and the secondary session qualifiers. The half-session name of the ISC node communicating with IMS consists of the logical unit name concatenated with its associated session qualifier. The IMS half-session name is the IMS ACB name concatenated with the session qualifier associated with IMS. The IMS session qualifier is the subpool name. Both half-session names are saved across session and IMS subsystem failures and are used to allocate, or validity-check when warm starting, the LTERM subpool to be used for the session.

## Controlling the Session (Session Control Protocols)

### Resolving a Bind Race

A race occurs when IMS and another logical unit simultaneously send BIND requests to each other and the two half-session names are mirror images. That is, the primary logical unit name and session qualifier concatenated with the secondary logical unit name and session qualifier of one side is equal to the primary logical unit name and session qualifier concatenated with the secondary logical unit name and session qualifier of the other side. The logical unit that wins and becomes primary is the one whose name (the primary logical unit name taken from each half-session name) is at the top of the standard collating sequence. This test prevents both sides from rejecting each other, resulting in no session.

### After a Successful Session Bind

Following a successful session bind, both half sessions must perform a resynchronization process. Message resynchronization is not performed when IMS is cold started or when a previous session instance between IMS and another logical unit has been normally shut down using the Stop Bracket Initiation/Bracket Initiation Stopped (SBI/BIS) procedure.

#### Related Reading:

- For more information on the resynchronization process, see “Resynchronizing Sessions.”
- For more information on session shutdown, see “Terminating the Session” on page 313 and “Symmetrical Session Shutdown for LU 6.1 (SBI and BIS)” on page 355.

---

## Resynchronizing Sessions

To maintain the integrity of recoverable resources, messages, and queues in IMS across both subsystem and session failures, both half sessions must maintain the session information required for the resynchronization process. Message integrity cannot be maintained without user intervention when either or both subsystems incur an error or when a user restart procedure destroys this information.

**Related Reading:** For more information on resynchronization process session requirements, see “Sync Point and Response Requirements” on page 323.

Resynchronization is required when it is possible for a recoverable work unit to be indoubt on a flow (primary-to-secondary or secondary-to-primary).

**Definition:** A *work unit* includes all transmissions between sync points within a bracket, as illustrated in Figure 56 on page 305. A sync point might have been requested by one or both half sessions without having been acknowledged. These conditions can be caused by a subsystem or session failure or an abnormal completion of a shutdown sequence.

Performing message resynchronization is unnecessary following a normal shutdown sequence (unless nonnegotiated BIND was sent), because both half sessions can come to a controlled, mutual understanding that no additional normal message traffic or sync-point requests are to occur prior to session termination. Message resynchronization is always required following nonnegotiable BIND to allow error conditions detected by the secondary half session to be communicated to the primary half session.

The half-session pairs resynchronize with the VTAM BIND, set-and-test-sequence-numbers (STSN), and start data traffic (SDT) commands. The STSN command allows

both half sessions to reestablish sync-point information (session sequence numbers), which is being maintained by both half sessions.

When message resynchronization is necessary, it must be completed successfully before either half session can resume normal data transmission.

Figure 56 shows two work unit examples.

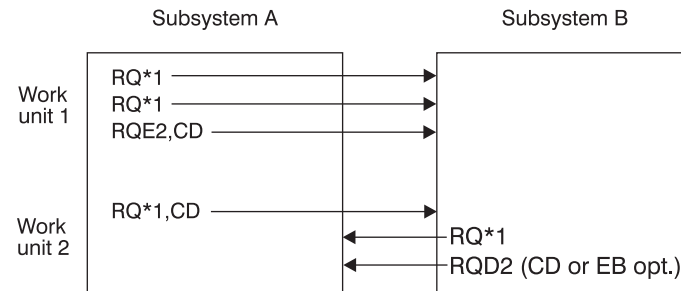

Figure 56. Work Unit Examples

In work unit 1 of Figure 56, a reply to the exception response request and CD creates an implied sync point. In work unit 2, sending the DR2 response to the RQD2 creates a sync point.

**Related Reading:** For more information on half-session synchronization, see “Keeping Half Sessions Synchronized” on page 321.

## Designing Restart Resynchronization Procedures

Resynchronization might or might not be required when IMS is restarted and when a session is established or reestablished. This topic addresses considerations for resynchronization at IMS restart and at session restart.

IMS restart provides for message recovery during:

- A normal IMS subsystem restart procedure, by restoring the IMS message queues and session restart information to the last or specified checkpoint
- An emergency IMS subsystem restart procedure by restoring the IMS message queues and session restart information to their states just prior to failure

If the failure occurred prior to a normal shutdown sequence between IMS and another logical unit, ensure that the session is restarted using the same half-session pairs (half-session names) that were in session at the time of failure. Further, when the session is resumed, the half-session pairs must maintain their previous relationship—that is, the former primary half session must again be primary, and the former secondary half session must be the current secondary.

### Maintaining Sequence Numbers

To allow session recovery and message resynchronization across session and subsystem failures, both half sessions must maintain a checkpoint of the following:

- Three sequence numbers that are produced when the session was last active  
The three sequence numbers are the potential (pending) and committed sequence numbers for the flow sent by the half session and the last committed sequence number for the flow received by the half session.
- An indicator produced when a unilateral decision was made by a half session to back out or commit a work unit that was left pending during the session outage

## Resynchronizing Sessions

- An indication of the direction of the decision

Sequence number mismatches and incorrect decisions to commit or back out a recoverable work unit are detected by comparing the sequence numbers sent or received on the VTAM set-and-test-sequence-number (STSN) command with the checkpointed resynchronization information. Each half session can detect invalid sequence number mismatches on their outbound flow and reject the resynchronization request. Each half session can also agree or disagree to unilateral decisions made by the other half session to commit or back out a work unit. This agreement or disagreement is based on the detection of a sequence number mismatch on the inbound flow and involves a second STSN when an incorrect decision is made on the STSN receiver's inbound flow. The STSN command receiver does this before responding to the second STSN command (which is sent in response to the receipt of TEST NEGATIVE on the first STSN). This second STSN informs the STSN receiver that a wrong decision had been made on its inbound flow.

### Recovering Sessions with Cold Start

Invalid sequence number mismatches and mismatches where no unilateral decisions have been made often indicate a subsystem restart from an incorrect log or incorrect checkpoint on the log. This situation can require forcing the recovery of the ISC session by cold starting one or both half sessions.<sup>26</sup> IMS allows authorized terminal operators to change IMS ISC session state from recoverable to cold start when necessary by using the IMS /ASSIGN (subpool to VTAMPOOL) command before attempting to initiate a session. When a session is changed to a cold-start state, the subpool associated with that session is made available for allocation to any ISC cold-startable parallel session with any node.

### Controlling Unilateral Decisions about Pending Work Units

To prevent resources from accidentally getting out of synchronization between subsystems, you can specify whether to continue session resynchronization after a session outage, where the other half session has made a unilateral decision to commit or back out a pending unit of work. IMS allows system definition to allow resynchronization without regard to inbound sequence number mismatches (OPTIONS=FORCESS on the TERMINAL macro statement or an ETO user descriptor), or to only allow resynchronization when the inbound sequence numbers agree (OPTIONS=SYNCESS). A keyword on the IMS /CHANGE command allows an authorized terminal operator to override the system definition specification for a single attempt to initiate a session. The effects of the CHANGE command are reset to the original system definition specification after one session initiation attempt. IMS does allow unilateral decisions to back out during session outages. However, using the IMS /DEQUEUE command for a session (terminal, and optionally, the subpool parameter) or LTERM during a session outage where an output-message sync point is pending is considered to be a unilateral decision by an authorized terminal operator to commit the pending output.

A pending output sync-point response can be determined by using the IMS /DISPLAY command. When two IMS subsystems are connected by an ISC session, the FORCESS option must be in effect on the opposite IMS subsystem from one where a pending output message was dequeued (committed) using a /DEQUEUE command, or session resynchronization fails with message DFS2065. Using FORCESS rather than SYNCESS has no other effect between two IMS subsystems.

---

26. Session recovery where one or both half sessions are cold started is not considered a major error because, by definition, the cold starting half session has no information from the previous active session with which to negotiate (agree or disagree) recovery or resynchronization.



## Recovering from In-Bracket Failures

When a session has failed while in-brackets, it might be necessary to restart the failed bracket when the session is restarted. The bracket state manager and the half-duplex reset flags in the bind can be set in either the BIND request or the negotiable bind response by either half session. These flags are set to in-brackets/SEND or RECEIVE to indicate the possibility that the process previously attached must be restarted.

## Response or Conversational Output Available at Restart

If, during session initiation, IMS has response mode or conversational output available to be sent or is in a sync-point response pending state, the bracket state manager reset and half-duplex flags within the IMS portion of the bind or bind response are set to in-brackets/SEND by IMS. If IMS is in conversation mode but has no conversational output available or pending, these same bind or bind reply flags are set to in-brackets/RECEIVE, because input is required to continue the conversation. IMS does not accept a nonnegotiated BIND or negotiated BIND response indicating IMS to be in-brackets/RECEIVE when conversation or response mode output is available. Unless a sync point is pending from a previous session, the session is resumed and the STSN that is sent must receive a TEST POSITIVE reply to the SET AND TEST option in order for processing to continue.

When IMS is in conversation or response mode and receives a nonnegotiated BIND or a response to a negotiated BIND indicating between-brackets, IMS attempts to terminate the conversation or response mode. This termination is just like that which occurs if end-bracket is received on an FMH7 or LUSTATUS while IMS is in conversation or response mode during normal data flow active state (after SDT).

Conversation and response mode termination is only assured when the output reply message is available to be sent or the half session is waiting for the next conversational input. Therefore, IMS restricts attempts to terminate conversation or response mode by binding between-brackets when the output reply is available to be sent or no conversational input is required. If no output reply is available to be sent or no conversational input is required, a warning message is sent to the IMS master terminal operator with instructions to retry session initiation later.

If IMS receives a negotiated BIND indicating in-brackets/SEND and is not in conversation or response mode, a BIND response is sent indicating between-brackets. IMS sends LUSTATUS - NO-OP indicating end-bracket immediately after SDT when IMS is not in conversation or response mode and when receiving a non-negotiated BIND or negotiated BIND response indicating in-brackets/SEND. LUSTATUS - NO-OP is sent because transaction restart is not possible under these circumstances.

It is possible that IMS is left in-brackets/SEND after a BIND or BIND response, because a conversation or response mode output sync-point response is pending from the previous session. The output message might be dequeued if STSN processing indicates that the response was sent. In this case, an LUSTATUS - NO-OP indicating end-bracket is to be sent after SDT if the output message is a response mode reply. An LUSTATUS - NO-OP indicating change-direction is sent if the output message is a conversational reply, because input is required to continue the conversation.

If STSN indicates that the conversation or response mode message was not acknowledged, IMS again places the message in a sync-point response-pending state as if it had been sent with change-direction and as if it had requested an exception sync-point response. Any normal flow reply is then considered implicit

## Resynchronizing Sessions

acknowledgment of the pending output message and causes it to be dequeued by IMS even if the reply was an LUSTATUS - Abort or an ATTACH ATTDPN=SYSMSG. These replies indicate additional error conditions associated with the message's scheduling or execution. Had the session not failed, these error conditions would have been reflected by an exception response to the sync-point request rather than the LUSTATUS - Abort or ATTACH ATTDPN=SYSMSG. Depending on the sense code used, the exception response might have caused the message to be returned to the message queue (backed out) for retransmission rather than dequeued (committed) as occurs for LUSTATUS - Abort or ATTACH ATTDPN=SYSMSG resulting when both a session and an application failure occur together.

### Session Failures without IMS Failure

A session failure not also involving an IMS subsystem failure might occur before IMS returns a requested sync-point response for a response mode or conversational input message. When the session is reestablished, the DFC state set by IMS using the bind is IMS in-brackets/SEND. The subsequent STSN sequence number recovery might reflect either that the input message has been committed (the transaction has reached a sync point after inserting a reply message) or that the input message has not yet been committed. In either case, IMS being bound as in-brackets/SEND indicates that the input message has been received and the other half session should wait for the reply message. Because session restart resets the original sync-point request, the reply message now becomes an implicit sync-point response to the original input message.

IMS recovers the fact that the session was in conversational mode (and also recovers associated input messages and output replies) across IMS outages. The fact that the session was in response mode (and any associated output replies) is only recovered across an IMS outage if the failure occurs after the transaction sync point that made the response mode reply available.

### Session Failures because of IMS Failure

A session failure that also involves an IMS subsystem failure might occur before IMS responds to a synchronization request on response mode (if the message was recoverable) or conversational mode input. When the session is reestablished, the DFC state set by IMS by the bind indicates IMS as bound in-brackets/SEND. In either case, because of the IMS restart process from the subsystem log, the subsequent STSN sequence number recovery reflects that the input message has been committed even if that commit has not yet actually occurred. However, this condition produces inconsistent results only if the transaction subsequently abnormally terminates after being restarted. In this case, the response mode output reply message is made available for asynchronous (ATTACH EB or ATTACH ATTDPN=SCHEDULER) delivery on the recovered ISC session.

### Recoverability of Commands and Execution Modes

IMS commands (except /DIS, /RDIS, and /FOR) and test-mode input are executed immediately without being placed on an input message queue. These commands complete all processing prior to causing output to be made available using a transaction sync point. Any failure causes the command or test mode transaction input and associated output message to be backed out and discarded.

IMS commands /DIS, /RDIS, and /FOR produce asynchronous queued output. Output that is enqueued prior to the failure is recovered and made available for asynchronous transmission when the session is reestablished.

Fast Path, recoverable response mode, and recoverable conversational mode transactions are backed out and discarded if the failure occurs before a transaction sync point. The fact that the session was in response mode is not recovered.

### Coordinating the Restart Process

These rules are used by the half sessions to coordinate restart after a session failure:

- The restart always occurs from the most currently completed sync point.
  - The session bind establishes the half-duplex state at the current sync point.
  - When the primary half session wants to restart:
    - It sends a BIND request to select the proper half-duplex state.
    - The secondary half session cannot change this state in the BIND response, unless the secondary half session does not want to restart.
    - When the secondary half session does not want to restart, it sends a BIND response to preclude restart by setting the bracket state to between-brackets.
  - When the primary half session does not want to restart:
    - The primary half session sends a BIND request setting the bracket state to between-brackets.
    - If the secondary half session wants to restart, it sends a BIND response that establishes the proper half-duplex state and sets the bracket state to in-brackets.
    - If the secondary half session does not want to restart, the secondary half session' response to the BIND does not change (it matches the state set by the primary half session).
  - STSN is used to resynchronize any pending requests for sync-point responses.
    - If no mismatch occurred, agreement exists on the current sync point. The restart is attempted after sending start data traffic (SDT).
    - It might be necessary for the half session in send state to send LUSTATUS - NO-OP, CD to adjust the half-duplex state to the current sync point based on the STSN.
- Related Reading:** For more information on the LUSTATUS protocol, see "LUSTATUS Protocol" on page 343.
- If a mismatch occurred and the session continues, the half session in send state sends LUSTATUS - NO-OP, EB to place the session into contention.
- The session in send state at the final restart point reestablishes the session by sending an explicit ATTACH.

Half sessions assuming a secondary role must reject a session bind in these situations:

- Session bind parameters indicate in-brackets, "other half session speaks first", and response mode or conversational output (or equivalent) are immediately available at data traffic active state. This is a session restart logic error.
- On restart following an abnormal failure or shutdown sequence, session bind parameters indicate half-session names different from those in effect during the previous session between IMS and another logical unit.

In an ISC session, either subsystem can assume a primary or a secondary half-session role, and either subsystem can request message resynchronization; therefore, a set of rules must be established by which these half-session pairs can maintain message or sync point integrity.

## Resynchronizing Sessions

These topics describe the format of the STSN and how the STSN is used to complete resynchronization and recovery.

### Determining Session Synchronism Using STSN

The need to resynchronize can be communicated during bind negotiation; two flags in the BIND request are used to determine the requirement to resynchronize and to return the half sessions to the state that existed at the time of session termination.

If both half sessions have terminated normally (that is, neither had any outstanding traffic to handle), the session is restarted as though it were a new session—bind parameters are sent, and no requirement exists that the relative positions of the session partners be maintained, nor that the same half-session names be used. The two flags upon which this determination is made are:

- Sequence number indicator
  - 1 = Sequence numbers available
  - 0 = Sequence numbers not available
- Bracket initiation stopped (BIS) indicator
  - 1 = BIS sent
  - 0 = BIS not sent

**Related Reading:** For more information on the BIS indicator, see “Symmetrical Session Shutdown for LU 6.1 (SBI and BIS)” on page 355.

Table 26 is a matrix describing the states set by these two flags in relation both to the bind sender (primary half session, or PHS) and the bind receiver (secondary half session, or SHS).

When both half sessions are in a “COLD START” state, no sequence numbers are available or required to be sent. Session shutdown is such that resynchronization is not required. The bind is negotiated and the session started in accordance with the bind parameters. For a nonnegotiable BIND, some information required by both half sessions is not available until STSN flows exist. Therefore, for a nonnegotiable BIND, STSN is always sent.

**Related Reading:** For more information on the resynchronization process that occurs for these conditions, see “Performing the Resynchronization” on page 311.

*Table 26. BIND Action/Response Matrix*

Bind Sender (PHS)	Bind Receiver (SHS)		
	Numbers Not Available	Numbers Available, BIS Sent	Numbers Available, BIS Not Sent (See Table 27)
Numbers Not Available	COLD STSN not required Send RESET to NOBB	COLD STSN not required Send RESET to NOBB	COLD/WARM mismatch STSN sent
Numbers Available BIS Sent	COLD STSN not required Send RESET to NOBB	COLD STSN not required Send RESET to NOBB	WARM STSN sent
Numbers Available BIS Not Sent (Table 28 on page 316)	WARM/COLD mismatch STSN sent	WARM STSN sent	WARM STSN sent

IMS sets the “BIS sent” and “sequence numbers available” flags in the negotiable BIND and BIND response (or PHS and SHS, respectively) as follows:

- Session cold start following IMS cold start or normal session termination:
  - BIS not sent
  - Sequence numbers not available
- Session restart
  - Previous session terminated normally following attempted normal termination by IMS:
    - BIS sent
    - Sequence numbers available
- Previous session terminated abnormally (normal termination by IMS not attempted):
  - BIS not sent
  - Sequence numbers available

**Related Reading:** For information on the format of the STSN command, see “STSN Command Format” on page 317.

### Performing the Resynchronization

When a session is reestablished (or established for the first time), the sequence numbers available for synchronization in each half session can, for each flow, represent the following states:

- COLD

This session has no sequence numbers to send or to compare. The primary half session indicates this by resetting the sequence number indicator bit in the BIND request. If the BIND is negotiable, the secondary half session indicates this by the same bit setting in the BIND response. If STSN is required (as for nonnegotiable BIND), the primary half session sends a SET AND TEST action code with zeros as the sequence number values.

- NOT PENDING

This session has no work units that are indoubt (that is, waiting to be committed)

- PENDING

One work unit is in doubt (waiting to be committed). The sequence numbers available to the session are the committed number (the sequence number of the last message to be committed) and the potential number (the sequence number of the last message to be issued).

- DECISION TO COMMIT

An indoubt work unit is committed during the session outage. Potential and committed numbers are still available. (A decision to commit occurs only as the result of a /DEQ command being issued during a session outage.)

- DECISION TO BACK OUT

An indoubt work unit is backed out during the session outage. Potential and committed numbers are still available. (IMS does not back out work units, but other session partners might).

- INVALID

Invalid sequence numbers are detected. (An invalid sequence number is one that should not occur, as, for example, a sequence number sent on the secondary-to-primary flow that does not match the committed or potential

## Resynchronizing Sessions

numbers saved by the STSN receiver.) This type of condition usually indicates an incorrect log data set; the master terminal operator must intervene to recover the session.

- RECEIVED PENDING (Sync-Point Response Lost)  
The receiver of this flow receives the entire work unit that the sender sends and generates a DR2 that might be lost in the network.
- NOT RECEIVED PENDING (Sync-Point Response Not Lost)  
The receiver of this flow never receives the RQ\*2 that the sender sends and therefore backs out the work unit that the sender is pending on.

The half sessions exchange information on their respective states by using bind negotiation and the action codes in the STSN request and response.

**Related Reading:** For information on the codes sent on STSN and the consequences, see "Using STSN to Resynchronize Sessions" on page 314.

---

## Completing Session Initiation

After the half sessions are in sync, either half session can decide to accept or reject the session:

- If the primary half session does not want to continue the session, it sends UNBIND.
- If the primary half session wants to continue the session, it sends start data traffic (SDT).
  - If the secondary half session responds positively, the session is formally bound and traffic on the session can begin.
  - If the secondary half session wants to discontinue the session, it rejects the primary half session's SDT, whereupon the primary must respond with an UNBIND and the session terminates.

Session initiation, including allocation of the LTERM subpool, is completed when a start data traffic (SDT) response has been received if IMS is the primary half session or when an SDT response is sent if IMS is the secondary half session. The LTERM subpool remains allocated to the other half-session name, even across session or subsystem failures, until the session is terminated by mutual consent of both half sessions (symmetrical shutdown). This requires that, after they have been allocated, all subsequent session binds for the same half session must specify the same bind session qualifiers that were active at abnormal session termination until the subpool is released through normal session termination.

If the session is terminated prior to the completion of SDT, any newly attempted subpool allocation caused by a session cold start is backed out, and the subpool is returned to an available-for-allocation status.

In IMS, the master terminal operator must always be notified of any session that is rejected prior to a start data traffic (SDT) completion. In an ISC session, notification to the IMS master terminal operator is optional for normal initiation and termination sequences. Operator notification is specified by the OPTIONS keyword parameters MTOMSG and NOMTOMSG on the TYPE and TERMINAL macros or by an ETO logon descriptor.

---

## Running the Session

Use the data flow control protocols to control the flow of data in an ISC session.

### **Related Reading:**

- For information on the data flow protocols, see “Handling IMS Response Mode or Conversational Output Errors” on page 319 and “Data Flow Control Protocol Reference” on page 329.
- For information on response and conversation mode errors and transaction sync points, see “Handling IMS Response Mode or Conversational Output Errors” on page 319.

---

## Terminating the Session

**Definition:** *Session termination* releases a logical unit from its current connection to the VTAM application program, making the LU available for sessions with other VTAM applications, or terminating communications altogether.

The two types of session termination are normal and abnormal.

### **Definitions:**

- *Normal termination* allows both half sessions to complete normal processing before the session is terminated.
- *Abnormal termination* forces the session to terminate unconditionally.

Session termination can be invoked by the IMS master terminal operator, the VTAM network operator, or either half session.

Because of this variety of session termination methods, each IMS network installation must determine specific procedures for session termination. When developing these procedures, consider the requirements for session-termination processing.

## Normal Termination

Normal termination of an ISC session occurs with the flow of the data flow control indicators stop bracket initiation (SBI) and bracket initiation stopped (BIS). Normal termination can be initiated by either half session.

**Related Reading:** For more information on SBI and BIS, see “Symmetrical Session Shutdown for LU 6.1 (SBI and BIS)” on page 355.

Normal session termination also occurs when the MTO invokes an orderly termination of the IMS network by the IMS /CHECKPOINT command with the FREEZE, PURGE, or DUMPQ parameter and the QUIESCE parameter. The QUIESCE parameter ensures that message queues are emptied before the session is terminated.

When all terminals have indicated that shutdown is complete, IMS:

- Performs checkpoint processing and then issues the VTAM CLSDST macro instruction, when acting as primary half session.
- Awaits UNBIND, if acting as secondary half session.

## Terminating the Session

CLSDST causes VTAM to send the UNBIND command. CLSDST or UNBIND releases the logical units from session with IMS. Any further data transmission to the logical units is prohibited.

During the processing of an orderly session termination, the IMS master terminal operator can terminate the network unconditionally by using an IMS /CLSDST, /STOP, or /CHECKPOINT command.

## Abnormal Termination

Abnormal session termination can occur as a result of transmission or protocol errors, or errors in data that make that data unacceptable to the receiving message processing program. Because an ISC session involves two peer-level systems, error recovery processing and abnormal session termination processes can differ. IMS-detected error conditions requiring abnormal session termination result in IMS issuing a VTAM CLSDST macro when IMS is the primary half session, or TERMSESS with OPTCD=UNCOND when IMS is the secondary half session.

**Related Reading:** For information on the effects of error recovery processing and some situations that can result in abnormal session termination, see “Data Flow Control Protocol Reference” on page 329.

---

## Using STSN to Resynchronize Sessions

Table 27 and Table 28 on page 316 show the results and actions related to using STSN for primary-to-secondary (P-S) and secondary-to-primary (S-P) flows. The first result in each table cell represents the STSN command action; the second result represents the response returned to the STSN command. These are separated by a slash (/). When two STSNs are sent, they are separated by a comma.

## Primary-to-Secondary Flow Matrix

Table 27 illustrates the actions taken when resynchronizing a session and the STSN command flows from the primary half session to the secondary half session.

*Table 27. STSN Primary-to-Secondary Flow*

Primary Half Session	Secondary Half Session		
	Session Cold	Not Received: Pending	Received: Pending
Pending	<b>1</b> Set and Test / Reset	<b>2</b> Set and Test / Negative	<b>3</b> Set and Test / Positive
Decision to Commit	<b>4</b> Set and Test / Reset	<b>5</b> Set and Test / Negative, Set / Positive	<b>6</b> Set and Test / Positive
Decision to Back Out	<b>7</b> Set and Test / Reset	<b>8</b> Set and Test / Positive	<b>9</b> Set and Test / Negative, Set/Positive
Not Pending	<b>10</b> Set and Test / Reset	<b>11</b> Set and Test / Positive	Not Applicable

### Notes To Table 27:

**1** The STSN sender is PENDING. The STSN receiver has no sequence numbers. A COLD/WARM mismatch has occurred. The session can continue. The STSN sender should continue the session.



## Using STSN to Resynchronize Sessions

- 2** The STSN sender is PENDING. The STSN receiver never received the pending RQ\*2 and returns a TEST NEGATIVE in the STSN response. The STSN sender backs out the pending work unit to the last commit point.
- 3** The STSN sender is PENDING. The STSN receiver received the pending RQ\*2 and sent a + DR2. The STSN receiver responds TEST POSITIVE, and the STSN sender commits the pending work unit.
- 4** The STSN sender wants to release the locks and commit resources; however, an RQ\*2 is outstanding. The STSN receiver has no sequence numbers. A COLD/WARM mismatch has occurred. The session can continue. The STSN sender should continue the session.
- 5** The STSN sender wants to release the locks and commit resources; however, an RQ\*2 is outstanding. The STSN receiver never received the pending chain, as indicated by TEST NEGATIVE in the STSN response. The STSN sender sends a second STSN with the SET action code to inform the STSN receiver that a wrong decision was made. The STSN receiver can continue the session by sending TEST POSITIVE or decline by sending INVALID.
- 6** The STSN sender wants to release locks and commit resources; however, an RQ\*2 is outstanding. The STSN receiver received the pending chain and committed it, as indicated by the TEST POSITIVE in the STSN response.
- 7** The STSN sender wants to back out the pending work unit, but a pending RQ\*2 is outstanding. The STSN receiver has no sequence numbers. A COLD/WARM mismatch has occurred. The session can continue. The STSN sender should continue the session.
- 8** The STSN sender wants to back out the pending work unit, but an RQ\*2 is outstanding. The STSN receiver never received the pending chain, so the sequence numbers match. A TEST POSITIVE is returned on the STSN response.
- 9** The STSN sender wants to back out the pending work unit, but an RQ\*2 is outstanding. The STSN receiver received the pending chain and committed resources. Because the STSN sender sent out the old committed sequence numbers and the STSN receiver received the chain, a TEST NEGATIVE is returned. The STSN sender informs the STSN receiver that a wrong decision has been made by sending a second STSN with a SET action code. The STSN receiver can continue the session by sending TEST POSITIVE or decline by sending INVALID.
- 10** The STSN sender is not pending on the P-S flow. The STSN receiver has no sequence numbers. The session continues.
- 11** The STSN sender is not pending on the P-S flow. The STSN receiver agrees with the sequence numbers on the STSN and returns a TEST POSITIVE.

## Secondary-to-Primary Flow Matrix

Table 28 on page 316 illustrates the actions taken when resynchronizing a session and the STSN command flows from the secondary half session to the primary half session.

## Using STSN to Resynchronize Sessions

Table 28. STSN Secondary-to-Primary Flow

Primary	Secondary					
	Session Cold	Pending	Decision To Commit	Decision To Back Out	Invalid	Not Pending
Not Received: Pending	<b>1</b> Set and Test / Reset	<b>2</b> Set and Test/ Positive	<b>3</b> Set and Test/ Negative	<b>4</b> Set and Test/ Positive	<b>5</b> Set and Test / Invalid	<b>6</b> Set and Test / Positive
Received: Pending	<b>7</b> Set and Test / Reset	<b>8</b> Set and Test/ Positive	<b>9</b> Set and Test/ Positive	<b>10</b> Set and Test/ Negative	<b>11</b> Set and Test / Invalid	Not Applicable

### Notes To Table 28:

- 1** The STSN sender is not COLD. The STSN receiver has no sequence numbers. The session continues.
- 2** The STSN receiver has a pending work unit and has held onto locks and not committed resources. The sequence number sent on the SET AND TEST action code indicates that the STSN sender did not receive the pending RQ\*2. Therefore, the STSN receiver backs out the pending work unit to the last commit point and returns a TEST POSITIVE on the STSN response.
- 3** The STSN receiver had a work unit pending and decides to commit resources and release locks. The STSN sender did not receive the RQ\*2 sent by the STSN receiver. The STSN receiver returns a TEST NEGATIVE on the STSN response to inform the STSN sender that a wrong decision was made. The STSN sender can continue the session by sending SDT or decline by sending UNBIND.
- 4** The STSN receiver had a work unit pending and decides to back out the pending work unit. The STSN sender never received the pending work unit, and the STSN receiver returns a TEST POSITIVE on the STSN response.
- 5** The STSN receiver detects a severe loss of synchronization (possible log data set mismatch) and returns an INVALID on the STSN response.
- 6** The STSN receiver has no pending work unit and agrees with the sequence numbers sent on the STSN; therefore, it replies with a TEST POSITIVE.
- 7** The STSN sender is not COLD. The STSN receiver has no sequence numbers. The session continues.
- 8** The STSN receiver has a pending work unit and still holds resource locks. The number sent by the STSN sender on the S-P SET AND TEST indicate to the STSN receiver that the STSN sender received the pending work unit. The STSN receiver commits the pending work unit and responds TEST POSITIVE.
- 9** The STSN receiver had a pending work unit and decides to commit the pending work unit. The number sent by the STSN sender on the S-P flow indicates that the STSN sender received the RQ\*2 and a TEST POSITIVE is sent on the STSN response.
- 10** The STSN receiver had a pending work unit. The receiver decides to back out that work unit and release the locks. The number sent

by the STSN sender on the S-P flow indicates to the STSN receiver that the RQ\*2 was received and processed by the STSN sender. The STSN receiver indicates the wrong decision by a TEST NEGATIVE on the STSN response. The STSN sender can continue the session by sending SDT or decline by sending UNBIND.

### 11

The STSN receiver detects a severe loss of synchronization (possible log data set mismatch) and indicates this to the STSN sender by an INVALID in the STSN response.

---

## STSN Command Format

Both the STSN command and STSN response contain a 5-byte data field. The format of the STSN command is:

<b>Byte 0</b>	Action code
<b>Bytes 1, 2</b>	Sequence number of the last inbound sync point message sent to the PHS
<b>Bytes 3, 4</b>	Sequence number of the last outbound sync point message sent from the PHS

The primary half session uses the action code to ask the secondary half session to verify the VTAM sequence numbers. The bits of the action code byte are as follows:

<b>Bits 0 and 1</b>	Refer to the inbound sequence-number field
<b>Bits 2 and 3</b>	Refer to the outbound sequence-number field
<b>Bits 4 through 7</b>	Reserved

These values are acceptable for bits 0, 1, 2, and 3 of the STSN command action code:

**00 IGNORE** Do not alter value. IMS does not send this action code value as PHS. IMS as SHS returns an INVALID response code for this action code when resynchronization is required and TEST POSITIVE when resynchronization is not required.

**01 SET** Set the appropriate sequence number to the value indicated in the sequence number field. For ISC, this code only occurs when the PHS must send a second STSN to indicate a unilateral decision was made to commit or back out a pending work unit.

**10 SENSE** Do not alter value. The SHS should return its version of the sequence number in the command response. IMS as SHS returns an INVALID response to this action code.

### 11 SET AND TEST

Set the appropriate sequence number to the value indicated in the sequence number field. For ISC, this code always occurs for both flows on the first STSN sent by the PHS. The SHS must indicate in the command response whether the sequence number values are acceptable.

When the secondary half session receives the STSN command, it must be able to:

- Verify the SHS-outbound (PHS-inbound) sequence number and arrange to retransmit a message to the PHS if required.

## STSN Command Format

- Verify the SHS-inbound (PHS-outbound) sequence number and inform the PHS whether the number matches the SHS-saved number. Further, the SHS might or might not agree with unilateral decisions by the PHS to commit or back out a pending work unit from the previous session.
- Return to the PHS a DR1 and a 5-byte data response to the STSN command.

The format of the STSN response has the same format as the STSN command:

<b>Byte 0</b>	Action code
<b>Bytes 1, 2</b>	Sequence number of the last recoverable message the SHS sent to the PHS
<b>Bytes 3, 4</b>	Sequence number of the last recoverable message the SHS received from the PHS

The secondary half session (SHS) uses the action code to indicate the test results. The action code must be returned to the primary half session (PHS). Returning the sequence numbers (bytes 1 through 4) is optional. However, for debugging recovery and restart problems, always return these to the PHS whenever the STSN numbers do not match those maintained by the SHS. The bits of the action code byte are as follows:

<b>Bits 0 and 1</b>	Refer to the SHS inbound sequence number
<b>Bits 2 and 3</b>	Refer to the SHS outbound sequence number
<b>Bits 4 - 7</b>	Reserved

These values are acceptable for bits 0, 1, 2, and 3 of the STSN response action code:

**00 RESET** Returned on both sequence number flows in response to the SET AND TEST option to indicate that the SHS must cold start and has no sequence number information. The PHS should continue session initiation and should not treat this response as an error. IMS sends this code when cold-starting and replying to STSN, and continues the session when receiving it.

### **01 TEST POSITIVE**

Returned in response to the SET AND TEST option to indicate that the sequence number agrees with the sequence number that the SHS checkpointed. This code should be returned in response to the SET option when the SHS agrees to continue session initiation following a unilateral decision by the PHS to commit or back out a pending work unit on its outbound flow during the session outage.

**Related Reading:** For more information on IMS action for unilateral decisions, see “Controlling Unilateral Decisions about Pending Work Units” on page 306.

**10 INVALID** Returned in response to the SET AND TEST option to indicate that the STSN SHS outbound sequence number does not agree with the sequence number that the SHS checkpointed (major session restart mismatch). INVALID is also returned in response to the SET option to indicate disagreement with a unilateral action by the PHS to commit or back out a pending work unit on its outbound flow. The PHS should not continue the session when receiving an INVALID response to either flow.

**Related Reading:** For more information on IMS action for unilateral decisions, see “Controlling Unilateral Decisions about Pending Work Units” on page 306.

## 11 TEST NEGATIVE

Returned in response to the SET AND TEST option on the SHS inbound flow to indicate that the sequence number does not agree with the sequence number checkpointed by the SHS. The PHS responds with SDT if the reason for the mismatch is a pending work unit sent by the PHS, but is not received by the SHS; with a second STSN indicating the SET option for both flows if the PHS had made a unilateral decision to commit or back out a pending work unit; or UNBIND if no work unit was pending and no unilateral decision had been made (major session restart mismatch). TEST NEGATIVE can also be returned in response to the SET AND TEST option to indicate that the SHS had made a unilateral decision to commit or back out a pending work unit on its outbound flow. In this case, the PHS can optionally agree to continue session initiation by sending SET or not to continue session initiation by sending UNBIND.

**Related Reading:** For more information on IMS action for unilateral decisions, see “Controlling Unilateral Decisions about Pending Work Units” on page 306.

---

## Handling IMS Response Mode or Conversational Output Errors

This topic describes how IMS handles response and conversational mode errors during an ISC session and how to keep the half sessions in sync.

IMS messages cannot be cancelled by session termination or protocols after they have been received and enqueued (made available for scheduling). However, errors can be detected by either half session after the input message has been enqueued. If the error is detected by IMS while processing the transaction, but before the reply message is committed (for example, a DFS555 transaction abend occurs), both half sessions are able to back out, because IMS holds the input sync-point response until the reply message is available for output. An exception response and appropriate error recovery process (ERP) message are returned. Errors occurring after the reply message is made available for output result in backout to the last application sync point (the one that made the reply message available). These errors are not communicated to the other half session.

After an exception response to a DFC command, you might need to purge before further sends or receives.

**Related Reading:** For information on the DFC protocols, see:

- For brief explanations and format tables for individual data flow control protocols, see “Data Flow Control Protocol Reference” on page 329.
- For information on ERP purging, see “ERP Purging” on page 340.
- *Systems Network Architecture Format and Protocol Reference: Architectural Logic.*

## Response Mode Errors

Errors detected by the other half session cannot be communicated to IMS until IMS attempts to send the reply. At this point, errors must be communicated to IMS before the requested sync-point response is returned, because all response mode

## Response Mode or Conversational Output Errors

output is sent indicating RQD and EB. Errors are reflected by the return of an exception response with an optional ERP message, which might contain appropriate sense data and protocols.

The exception response or ERP FM header sense codes can cause the output message to be backed out (dequeued) or retransmitted, or they can cause the session to terminate with the message still on the queue. ERP message protocols can cause the message to be backed out (dequeued) regardless of the sense code through use of EB or can leave IMS in send state through use of CD. This latter case is only allowed if the sense code used results in the output message being dequeued or retransmitted.

An LUSTATUS - abort with EB is sent as the next output on the session if CD is used on the ERP message and the sense code results in dequeuing the response mode output message. However, in all of the cases where the error is detected by the other half session, the reply message is the only resource that IMS can back out. The database updates and other messages initiated by the response mode transaction cannot be backed out by IMS.

## Conversational Mode Errors

Errors detected by the other half session cannot be communicated to IMS until IMS attempts to send the output reply. Errors must be communicated to IMS before the requested sync-point response is completed. For nonlast conversational output, the sync-point requested using RQE2 with CD and any returned normal flow data implicitly completes the sync point. The last conversational output message is sent requesting RQD2 with EB. Errors are reflected either by returning an exception response with an optional ERP message (which might contain appropriate sense data and protocols) or by returning an LUSTATUS with appropriate sense codes and protocols.

The sense codes can cause the message to be backed out (dequeued) or retransmitted, or they can cause the session to terminate with the message still on the queue. ERP and LUSTATUS message protocols can cause the message to be backed out (dequeued) using EB, or they can leave IMS in send state using CD. This latter case is only allowed if the sense code retransmits the message or if the last conversational output for the sense code dequeues the output message. An LUSTATUS - abort with EB is sent as the next output on the session if CD is used on the LUSTATUS or ERP message, and the sense code results in dequeuing the last conversational mode output message.

When the error is detected by the other half session, the output reply message is the only resource that IMS can automatically back out. The database updates, conversational SPA, and other messages initiated by the conversational transaction cannot be automatically backed out by IMS. However, for conversations, an internal IMS /EXIT command is scheduled to invoke the user's Conversational Abnormal Termination exit routine, which can optionally schedule a transaction to reverse necessary database changes based on the conversational SPA content. The interface to the exit routine is the same as if an /EXIT command had been received on the session.

**Related Reading:** For more information on this interface, see "Conversational Abnormal Termination Exit Routine (DFSCONE0)" in *IMS Version 9: Customization Guide*.

---

## Normal Conversation Termination Extension with ISC

In a non-ISC environment, normal termination of IMS conversation mode occurs when the IMS transaction creates a blank in the transaction-code field of the conversational SPA prior to committing the reply message. The conversation ends when the reply message has been successfully dequeued. An extension for normal termination has been made for ISC, because the peer-level application in the other half session can also now end the conversation. However, IMS supports this request for normal termination by receiving only an SNA-defined commit request - LUSTATUS X'0006' with EB. This occurs because of a stand-alone commit request (or normal termination) by the remote application to its subsystem. This form of conversational termination requires notification of the user using the Conversational Abnormal Termination exit routine (new input vector of X'28' in byte 3 of register 1), because committing changes might have been deferred by the completed conversational steps. This is possible by recording the deferred information within the conversational SPA. The exit routine can schedule an appropriate transaction to commit the deferred changes upon being invoked with the new vector.

**Restriction:** IMS does not support an input message with EB to terminate the conversation.

---

## Keeping Half Sessions Synchronized

This topic describes the synchronization requirements for ISC sessions and the attached application programs.

**Related Reading:** For information on sync points and associated commit or backout processes for the IMS application program interface, see *IMS Version 9: Application Programming: Transaction Manager*.

Sync-point responses (DR2) are used between ISC session partners to ensure that both partners' sync-point managers can commit or back out recoverable resources synchronously. All messages sent or received on an IMS ISC session are defined as either recoverable or irrecoverable, depending on the message type. The session-response protocols are used to ensure that both ends of an ISC session mutually understand the recoverability attributes associated with each message. The response protocol used must be consistent with the IMS message type.

The ISC sync point can be explicit or implicit:

### Explicit

The input requests an RQD2 response.

### Implicit

The input requests the sending of an exception response (RQE2) and change-direction on output made available by the transaction, or the sending of an LUSTATUS in lieu of output data from the transaction).

To further increase integrity and recoverability, IMS can supplement the sync point facility by logging the information. Use of log write-ahead ensures that the sync point indication is recorded on the log. This makes sync point information available to IMS restart procedures before the sync-point response is actually sent or change-direction is replied to (implied sync point).

**Related Reading:**

## Keeping Half Sessions Synchronized

- For more information on the sync point requirements, see “Sync Point and Response Requirements” on page 323.
- For tables showing the VTAM indicators used in IMS messages to request and respond to sync points, see “Sync-Point Indicators on Messages” on page 326.

Before reading these topics, be sure to understand the definitions and relationships of the ISC sync point and associated commit and backout processes to the IMS application program, described in these paragraphs.

### Sync Points Requested on Input to IMS

For any type of input, IMS does not schedule the intended transaction until the complete input message is successfully received. Sender-detected errors, errors resulting from processing of IMS input, and session failure prior to the receipt of the complete input message cause the entire message to be discarded or backed out. However, the input message cannot be cancelled by ISC session failures or protocols after the complete message is received and made available for scheduling.

When an input message is backed out because of errors detected during IMS input processing or during synchronous transaction execution, the session partner is notified, either by means of session termination or by an exception response to the ISC input. These events occur for this backout:

- Backout results in resetting the associated DFC and ATTACH states to those of the last sync point.
- Backout during transaction execution results in backing out application updates and messages, except express messages made after the last application sync point.
- The application sync point and ISC sync point are not necessarily the same.
- Backout during input to IMS has no effect on other recoverable IMS resources, such as databases, because input messages are not available for scheduling or execution until they are received completely and without error.
- The result of the backout is only the current input message, even if several consecutive input (irrecoverable) messages were received and executed or enqueued for scheduling after the last input sync point was requested from IMS.

The definition and relationship of successful ISC input sync points to IMS application sync points depend upon whether the ISC input was synchronous or asynchronous. For asynchronous input, the sync point reflects only that IMS is now responsible for message recovery. No implications exist relative to the scheduling or execution of transactions or to the availability of transaction output. After the message is successfully enqueued, the DFC and ATTACH sync point information is updated and the requested sync-point response is returned to the session partner.

Although some IMS exceptions for synchronous input exist, the sync point is intended to reflect the success of the IMS transaction execution and sync point. IMS updates the DFC and ATTACH sync point information as appropriate and commits all associated transaction resources (for example, DL/I databases) and the output transaction message reply when responding to the ISC attached input sync-point request.

These exceptions apply to sync points for synchronous input to IMS:

- The ISC sync-point response is returned by IMS when a transaction-inserted response mode or conversational reply message (first message inserted to the



I/O PCB or alternate response PCB) is made available for output using a transaction sync point. Additional transaction processing and sync points are not reflected in the ISC session. No ISC sync point-response occurs for transaction sync points prior to the transaction's inserting the reply message, as in a program-to-program switch. Nonfirst messages inserted to the I/O PCB or alternate response PCB, messages inserted to nonresponse PCBs, and IMS express messages intended for the ISC session are queued for future asynchronous delivery after successful delivery of the reply message.

- Except during program-to-program switches to another conversational transaction, IMS generates a subsystem error message as the result of abnormally terminating a conversational transaction that attempts to cause a transaction sync point without first having inserted an output conversational reply message. The subsystem error message causes an exception response to be sent to the input sync-point request and the input message to be backed out.

### Sync Points Requested on Output by IMS

IMS commits the output message when the requested sync-point response is returned by the other session partner. The message might also be committed as the result of some sense codes that are returned on an exception response to the requested sync-point response.

**Definition:** The term *commit* means that the message has been successfully sent and dequeued, and sync point information has been updated as appropriate.

Use of the IMS /DEQUEUE command during a session outage while an output sync-point response is pending is considered a unilateral decision by an authorized terminal operator to commit the sending output message.

Depending upon the sense code used, IMS backs out the output message when an exception response is returned to the sync-point request or when the IMS /DEQUEUE command is issued by an authorized terminal operator before IMS requests a sync-point response.

**Definition:** The term *backout* means that a recoverable message is returned to the message queue (unless dequeued by a /DEQUEUE command) for subsequent retransmission. An irrecoverable message is either dequeued or returned to the message queue for subsequent retransmission, depending upon the type of error. Normally, an exception response or IMS failure causes an irrecoverable message to be dequeued. Some session failures that do not result from a subsystem failure cause an irrecoverable message to be retransmitted at the first opportunity after resynchronization. Backout results in resetting the associated DFC and ATTACH states to those of the last sync point.

### Sync Point and Response Requirements

The IMS input/output message flow can be represented as an input/output flow from a sequential queue data set. In order to maintain integrity and recoverability of this queue data set, IMS requires that each recoverable input and output message establish a sync point between both half sessions before continuing the flow. This allows both half session sync-point managers to commit or back out resources in synchronism.

The sync point facility for ISC redefines and separates the DR1 and DR2 requests and responses. The DR2 requests and responses are known as sync-point requests and responses and are functionally independent from those associated with DR1.

### Recoverable Messages

To ensure that a recoverable transaction can be recovered, IMS requires these response protocols for each recoverable message sent or received:

- Messages that are not MFS-paged messages:
  - An exception DR2 (RQE2) must be requested on each nonlast (or when it is not the only) RU of an SNA chain.
  - Except when change-direction is sent, each last or only RU of an SNA chain must request a DR2 (RQD2). Either exception DR2 (RQE2) or RQD2 can be requested when change-direction is sent.
  - A sync-point response on the last or only RU of an SNA chain always indicates end-of-message. End-of-message always occurs at end-of-chain for single chain (non-MFS-paged) messages.
- First chain of asynchronous (ATTACH SCHEDULER) demand-paged message:
  - The first chain (OIC) of asynchronous demand-paged messages is an ATTACH for the SCHEDULER model. This OIC requests a DR2 (RQD2) with end-bracket. This allows the application to be asynchronously scheduled to receive the message and leaves the session in a state to be allocated to the scheduled application.
- Nonlast pages of MFS demand-paged (output using ATTACH or ATTACH SCHEDULER) messages, and last pages of MFS-operator logical-paged (OLP) output:
  - An exception DR1 (RQE1) is requested on each nonlast (or when it is not the only) RU of an SNA chain (MFS demand-page).
  - Each last or only RU of an SNA chain (MFS demand-page) requests exception DR1 (RQE1) with change-direction.
- Last pages of MFS demand-paged (output) messages:
  - An exception DR2 (RQE2) is requested on each nonlast (or when it is not the only) RU of an SNA chain (MFS demand-page).
  - Except when change-direction is sent on the last page, each last or only RU of an SNA chain (MFS demand-page) requests a DR2 (RQD2). Exception DR2 (RQE2) with change-direction is requested.
  - A sync-point response on the last or only RU of an SNA chain always indicates end-of-message. A sync point must always be requested on the last page of MFS demand-paged messages to ensure end-of-message.
- First, nonlast pages of MFS-autopaged messages:
  - An exception DR1 (RQE1) is requested on each nonlast (or when it is not the only) RU of an SNA chain (MFS autopage) sent to IMS and must be requested on each nonlast (or when it is not the only) RU of an SNA chain (MFS autopage) received by IMS.
  - RQD1 is requested on the last or only RU of the first SNA chain of an MFS-autopaged output message sent by IMS.
  - RQD1 must be requested on the last or only RU of the first SNA chain of an MFS-autopaged input message received by IMS when the other half session is initialized as the primary half session (bidder). Either exception DR1 (RQE1) or DR1 (RQD1) can be requested on the last or only RU of this SNA chain when the other half session is initialized as the secondary half session (first speaker). Change-direction is not sent and must not be requested on nonlast pages of MFS-autopaged input and output messages.
- Nonfirst, nonlast pages of MFS-autopaged messages:
  - An exception DR1 (RQE1) is requested on each RU (including last or only) of an SNA chain (MFS autopage) sent by IMS. An exception DR1 (RQE1) must be

requested on each nonlast (or when it is not the only) RU of an SNA chain received by IMS. Either exception DR1 (RQE1) or RQD1 can be requested on each last or only RU of an SNA chain received by IMS. Change-direction is not sent and must not be requested on nonlast pages of MFS-autopaged input and output.

- Last pages of MFS autopaged messages:

An exception DR2 (RQE2) is requested on each nonlast RU of an SNA chain (MFS autopage) sent by IMS and must be requested on each nonlast RU of an SNA chain (MFS autopage) received by IMS.

Except when change-direction is sent on the last page, each last or only RU of an SNA chain (MFS autopage) requests a DR2 (RQD2). Exception DR2 (RQE2) is requested when change-direction is sent.

Except when change-direction is received on the last page, each last or only RU of an SNA chain of an MFS-autopaged input must request a DR2 (RQD2). Either exception DR2 (RQE2) or definite response 2 (RQD2) can be requested when change-direction is indicated.

A sync-point response on the last or only RU of an SNA chain or on an LUSTATUS - commit always indicates end-of-message. A sync point must always be requested on the last page or on an LUSTATUS - commit following the last page of autopaged messages to ensure end-of-message.

**Related Reading:** For more information on LUSTATUS - commit, see “LUSTATUS Protocol” on page 343.

| For the case when allowing RQE1 on the last or only RU of an SNA chain that  
| does not indicate a change-direction for MFS-autopaged input or output, an  
| exception to the preceding protocols occurs when the session bind indicates  
| DEFINITE RESPONSE CHAINS. If the definite response chains parameter is set for  
| the IMS half session, each last or only RU defined that does not also indicate  
| change-direction is sent requesting RQD1 or RQD2. RQD1 or RQD2 must be  
| requested by the other half session under these same conditions if its session bind  
| indicates DEFINITE RESPONSE CHAINS. Both exception and definite response  
| (DR1 and DR2) are valid if change-direction is indicated under definite response  
| chain rules.

### Irrecoverable Messages

IMS treats an irrecoverable message in the same manner as a recoverable one, except that all processing required to achieve recoverability is eliminated. As a result, irrecoverable messages require less processing time, but can be lost in the event of a failure. Irrecoverable, non-MFS input and output messages basically have the same requirements as those for recoverable messages, except that DR1 and exception DR1 can optionally be requested instead of DR2 and exception DR2, respectively. Irrecoverable MFS-paged input and output messages have the same requirements as recoverable ones.

When messages are being sent, only one message can be outstanding at a time. This means that the sender can send one message and must wait for the response or reply before sending another.

The required response and sync-point protocol allows message integrity to be maintained by allowing the half sessions' sync-point managers to mutually understand when messages are accepted (committed) or rejected (backed out). This also allows change-direction to be solicited using SIGNAL RCD as required. RQE1 or RQE2 is recommended where change-direction is indicated, because these capabilities are automatic. An RQD1 or RQD2 are valid, but reduce performance

## Keeping Half Sessions Synchronized

because of the unnecessary response. A response or sync point is implied when a reply is received to a sent message indicating change-direction and RQE1 or RQE2. That is, the reply is an implied DR1 or DR2 response. Requesting either a definite response (RQD1 or RQD2) or an exception response (RQE1 or RQE2) with change-direction is valid for the session bind option DEFINITE RESPONSE CHAINS.

A failure can occur between sending a recoverable message and receiving the sync-point response (or reply) and receiving the sync-point response (or reply message). During the session restart procedure, the STSN command is used to inform both half sessions of the sequence number of the last sent or received sync-point message. If either half session has not completely received a given message, that message can then be retransmitted.

## Sync-Point Indicators on Messages

This topic describes the sync-point indicators sent on IMS input and output messages.

### Requests on IMS Input Messages

Table 29 summarizes the response and sync-point requests for input messages to IMS. An "X" in the table indicates the entry is supported by IMS. An "S" in the table indicates the corresponding entry is suggested.

**Related Reading:** For the description of CD and -CD, see "Bracket and Half-Duplex Protocol" on page 330.

Table 29. Response and Sync-Point Requests for IMS Input Messages

Input Message Type	VTAM Indicators with Message							
	RQE1 <sup>1</sup>		RQD1		RQE2 <sup>1</sup>		RQD2	
	CD	-CD	CD	-CD	CD	-CD	CD	-CD
Nonlast MFS page (autopage)		S		X				
Last MFS page (autopage)								
Recoverable and nonrecoverable					S		X	S
Fast Path conversational recoverable and nonrecoverable transaction								
Response mode transaction	S		X	X	S		X	X
Nonrecoverable, nonresponse, nonconversational mode transaction	S	S <sup>2</sup>	X	X	S	Note 2	X	X
Recoverable, nonresponse, nonconversational mode transaction						S	X	S

Table 29. Response and Sync-Point Requests for IMS Input Messages (continued)

Input Message Type	VTAM Indicators with Message							
	RQE1 <sup>1</sup>		RQD1		RQE2 <sup>1</sup>		RQD2	
	CD	-CD	CD	-CD	CD	-CD	CD	-CD
MFS paging control request: SNA-formatted QMODEL FMHs	S							
MFS paging control request: SNA RAP FMH					S		X	
IMS message switch								
IMS message switch using ATTACH SCHEDULER					S		X	S
IMS message switch using ATTACH (no SCHEDULER)								Note 3
ATTACH SYSMSG <sup>4</sup>								Note 3
IMS command	S		X	X	S		X	X
VTAM command <sup>5</sup>								
LUSTATUS - commit					S		X	S
Other	X		X	X				
Test mode <sup>6</sup>	S		X	X	S		S	X
FMH7 (ERP) messages	X	Note 3	X	Note 3				

**Notes:**

1. A response is implied by a reply to the change-direction indicator; therefore, RQE1 or RQE2 is recommended when change-direction is sent. Either method of requesting a response is supported for the session BIND option of DEFINITE RESPONSE CHAINS. When IMS is running as a secondary system, the other half session (as the primary system), if sending a BB-CD chain, must indicate RQD1 to allow proper DFC bracket and send/receive synchronization.
2. Supported only for irrecoverable-inquiry input requesting EB or BB/EB.
3. Sent with EB. BB is also sent as needed.
4. Because IMS SYSMSG is handled in the same manner as is a message switch, the same protocols apply.
5. LUSTATUS might indicate RQE1 with EB or BB/EB. CHASE, LUSTATUS, and CANCEL commands can optionally request RQE1 with CD. LUSTATUS - commit can also request RQE2 or RQD2 for specific conditions. All other normal flow VTAM commands must request RQD1.
6. Applies to test "echo" mode only. Not applicable to /TEST MFS.

**Requests on IMS Output Messages**

Table 30 summarizes the response and sync-point requests for IMS output messages. An "X" in the table indicates that the corresponding entry is supported by IMS.

**Related Reading:**

- For information on CD and -CD, see "Bracket and Half-Duplex Protocol" on page 330.

## Keeping Half Sessions Synchronized

- For information on using the abort and commit sense codes to ensure that both half sessions maintain a mutual understanding of the current sync point and the status of recoverable resources, see “LUSTATUS Protocol” on page 343.

Table 30. Response and Sync-Point Requests for IMS Output Messages

Output Message Types	VTAM Indicators with Message							
	RQE1 <sup>1</sup>		RQD1		RQE2 <sup>1</sup>		RQD2	
	CD	-CD	CD	-CD	CD	-CD	CD	-CD
Update, recoverable					X			X
Inquiry, recoverable					X			X
Inquiry, nonrecoverable	X			X				
Fast Path (recoverable)								X
Nonlast MFS page (autopaged)		Note 2		Note 2				
First chain demand-paged output								
ATTACH (no SCHEDULER)	X							
ATTACH SCHEDULER								X
Nonlast MFS page (demand-page)	X							
Last MFS page (autopaged or without OLP) recoverable, nonrecoverable					X			X
Last MFS page (with OLP) <sup>3</sup>	X							
IMS command reply: /DISPLAY, /RDISPLAY, /FORMAT					X			X
IMS command reply: /TEST	X							
Other IMS command replies				X				
Test mode output <sup>4</sup>	X			X				
Broadcast output (ATTACH SYSMMSG)					X			X
System error messages (ATTACH SYSMMSG)	X			X	X			X
Message switch output					X			X
VTAM commands <sup>5</sup>	X			X				
FMH7 (ERP) messages	X			Note 6				

Table 30. Response and Sync-Point Requests for IMS Output Messages (continued)

Output Message Types	VTAM Indicators with Message								
	RQE1 <sup>1</sup>		RQD1		RQE2 <sup>1</sup>		RQD2		
	CD	-CD	CD	-CD	CD	-CD	CD	-CD	
QSTATUS (QMODEL) <sup>7</sup>	X					X			X

**Notes:**

1. A response is implied by a reply to the change-direction indicator; therefore, IMS indicates RQE1 or RQE2 when sending the change-direction indicator. Either method of requesting a response is supported for the session BIND option DEFINITE RESPONSE CHAINS.
2. RQD1 occurs on each chain rather than RQE1 when IMS is bound as “RQD only,” and on the first page of MFS autopaged output to prevent unnecessary ERP overhead if errors or contention is detected by the receiver.
3. MFS operator logical paging is in effect if the MOD specifies PAGE=YES and autopaged output is not indicated in the MFS system control area.
4. Applies to test “echo” mode only. Not applicable to /TEST MFS.
5. CHASE is always sent RQE1/CD. See “LUSTATUS Protocol” on page 343 and “CANCEL Protocol” on page 338 for the DFC bracket, send/receive, and response requirements for LUSTATUS and CANCEL, respectively.
6. Sent with EB.
7. CD/RQE1 is sent on QSTATUS, which results from an invalid cursor in an MFS DPM demand-page request for output sent as ATTACH SCHEDULER. CD/RQE2 or EB/RQD2 is sent on QSTATUS, which results from the receipt of QPURGE during demand-paged output. CD/RQE2 is sent:
  - When operating in IMS conversation or in test mode
  - When the input is sent with ATTACH SCHEDULER and the associated output component is SINGLE2 or MULT2.
 All other cases result in EB/RQD2.

---

## Data Flow Control Protocol Reference

- The following topics describe the byte-level protocols for data flow control:
- “BID Protocol” on page 330
  - “Bracket and Half-Duplex Protocol” on page 330
  - “CANCEL Protocol” on page 338
  - “Chaining Protocol” on page 339
  - “CHASE Protocol” on page 339
  - “ERP Purging” on page 340
  - “LUSTATUS Protocol” on page 343
  - “Paged Messages ERP” on page 346
  - “Ready-to-Receive Protocol” on page 346
  - “RSHUT Protocol” on page 347
  - “Selective Receiver ERP” on page 347
  - “Sender ERP” on page 351
  - “Sense Codes that IMS Receives” on page 353
  - “Sense Codes that IMS Sends” on page 354
  - “SIGNAL Protocol” on page 355
  - “Symmetrical Session Shutdown for LU 6.1 (SBI and BIS)” on page 355

### BID Protocol

IMS does not send the SNA BID command, but receives the command when acting as a secondary half session.

When receiving the BID command in a between-bracket state, IMS responds DR1 and enters a receive state for the pending input. If the BID command is received while IMS is in-brackets, IMS rejects the BID with an exception DR1 response (X'08130000').

### Bracket and Half-Duplex Protocol

IMS uses SNA bracket protocol to resolve contention, and uses the change-direction indicator of the half-duplex protocol to control normal flow send/receive mode while within bracket state.

IMS uses these options when in session with another ISC logical unit:

- Bracket reset state can be selected at data traffic active state. This state can be set to between-brackets (BETB) or in-brackets (INB).
- Half-duplex send or receive state can be selected at data traffic active state.
- Either half session can send end-bracket (EB). IMS must always be bound to allow EB.
- Half-duplex flip-flop is used for normal flow send/receive states.
- Bracket termination rule 1 (conditional rule) is used.

#### Related Reading:

- For more information on session bind parameters, see Appendix B, “Bind Parameters for SLU P and LU 6.1,” on page 503.
- For information on bracket termination rules, see *Systems Network Architecture Format and Protocol Reference: Architectural Logic*.

### Bracket Protocol for IMS Input

One or more input messages can be received within a bracket as described in the bulleted list:

- Any number of nonresponse, nonconversation, noncommand, or nontest mode input messages can be sent within the bracket. The input, the subsequent asynchronous output, or an LUSTATUS can end the bracket. Further, a single nonresponse, nonconversation, noncommand, or nontest mode input message with ATTACH EB can be sent.
- One response mode or command message, except /TEST, can optionally occur within the same bracket after any of the input messages listed in the previous list bullet. The response mode or command message output ends the bracket.
- Any number of conversation or test mode inputs followed by conversation or test mode outputs can optionally begin within the same bracket after the input messages listed in the first list bullet. The bracket ends on the last conversation output message (or command complete message from /END for test mode). The bracket can also be ended by the other half session's sending an input LUSTATUS or CHASE with EB, but not by input data sent with EB.
- The bracket can be ended by an EB occurring on an FMH7 or LUSTATUS resulting from an error.



Table 31, Table 32, and Table 33 on page 332 summarize the bracket and send/receive indicators acceptable for the various message types input to IMS. An "X" in the table indicates that the corresponding entry is supported by IMS.

*Table 31. Bracket and Send/Receive Indicators for Messages Sent to IMS: Input Message Type Using ATTACH SCHEDULER*

Input Message Type Using ATTACH SCHEDULER	VTAM Indicators <sup>1</sup> Sent with Message					
	BB	EB	BB/EB	BB/CD	CD	¬BB, ¬EB, ¬CD
MFS-autopaged input: First page (of multiple page input)	X					X
MFS-autopaged input: Nonfirst, nonlast page						X
MFS-autopaged input: Last page: see transaction types						
Nonresponse transaction						
Nonconversational mode transaction	Note 2	Note 3	Notes 2, 3	Note 2	X	X
Response mode (including Fast Path) transaction	Note 2			Notes 2, 4	Note 4	X
Conversational transaction	Note 2			Notes 2, 4	Note 4	X
IMS message switch	X	X	X	X	X	X
IMS command	X	Note 5	Note 5	Note 4	Note 4	X
Input while in test mode <sup>5</sup>					Note 4	X

**Notes:**

1. Symbols:

- BB: Begin-Bracket
- EB: End-Bracket
- CD: Change-Direction. Allowed on Last- or Only-in-Chain.
- BB/EB: Begin- and End-Bracket. Allowed on First- or Only-in-Chain.

2. Not valid for the last page of MFS-autopaged input.

3. Not valid for the first page of MFS-autopaged input.

4. Denotes the optimal end-of-message indicators to prevent IMS from soliciting change-direction using SNA SIGNAL.

5. Valid only for /DIS, /RDIS, and /FOR commands. Also optimal for these commands to keep IMS from immediately forcing a between-brackets state by sending LUSTATUS - NO-OP (X'0006') with EB. The output from these commands is always queued and sent asynchronously.

6. FMH7 messages and LUSTATUS NO-OP indicating EB force end of conversation, response mode, and test mode and cause the associated IMS output message to be dequeued. Further, the Conversational Abnormal Termination exit routine is invoked. See the description of LUSTATUS and "Handling IMS Response Mode or Conversational Output Errors" on page 319.

*Table 32. Bracket and Send/Receive Indicators for Messages Sent to IMS: Input Message Type Using ATTACH (no SCHEDULER)*

Input Message Type Using ATTACH (no SCHEDULER)	VTAM Indicators <sup>1</sup> Sent with Message					
	BB	EB	BB/EB	BB/CD	CD	¬BB, ¬EB, ¬CD
MFS-autopaged input: First page (of multiple page input)	X					X

## Bracket and Half-Duplex Protocol

Table 32. Bracket and Send/Receive Indicators for Messages Sent to IMS: Input Message Type Using ATTACH (no SCHEDULER) (continued)

Input Message Type Using ATTACH (no SCHEDULER)	VTAM Indicators <sup>1</sup> Sent with Message					
	BB	EB	BB/EB	BB/CD	CD	¬BB, ¬EB, ¬CD
MFS-autopaged input: Nonfirst, nonlast page						X
MFS-autopaged input: Last page: see transaction types						
Nonresponse, nonconversational mode transaction		X	X			
Response mode (including Fast Path) transaction <sup>7</sup>	Note 2			Notes 2, 4	Note 4	X
Conversational transaction	Note 2			Notes 2, 4	Note 4	X
IMS message switch		X	X			
ATTACH SYSMG		X	X			
IMS command	X	Note 5	Note 5	Note 4	Note 4	X
Input while in test mode <sup>6</sup>					Note 4	X

### Notes:

1. Symbols:

- BB: Begin-Bracket
- EB: End-Bracket
- CD: Change-Direction. Allowed on Last- or Only-in-Chain.
- BB/EB: Begin- and End-Bracket. Allowed on First- or Only-in-Chain.

2. Not valid for the last page of MFS-autopaged input.

3. Not valid for the first page of MFS-autopaged input.

4. Denotes the optimal end-of-message indicators to prevent IMS from soliciting change-direction using SNA SIGNAL.

5. Valid only for /DIS, /RDIS, and /FOR commands. Also optimal for these commands to keep IMS from immediately forcing a between-brackets state by sending LUSTATUS - NO-OP (X'0006') with EB. The output from these commands is always queued and sent asynchronously.

6. Applies to test "echo" mode only. Not applicable to /TEST MFS.

7. For ISC, response mode operation is forced for attached transactions not indicating EB (regardless of their definition on the TRANSACT macro statement) when the TERMINAL macro statement or ETO user descriptor indicates either TRANRESP or FORCRESP. The input is rejected if the TERMINAL macro statement or ETO user descriptor indicates NORESP.

Table 33. Bracket and Send/Receive Indicators for Messages Sent to IMS: Other Input Message Types

Other Input Message Types	VTAM Indicators <sup>1</sup> Sent with Message					
	BB	EB	BB/EB	BB/CD	CD	¬BB, ¬EB, ¬CD
VTAM normal flow command/indicator <sup>2,3</sup>	X				X	X
FMH7 (ERP) messages		Note 6	X	X	X	
IMS MFS paging control request (QMODEL FMHs)				X	X	
RAP FMH					X	

Table 33. Bracket and Send/Receive Indicators for Messages Sent to IMS: Other Input Message Types (continued)

Other Input Message Types	VTAM Indicators <sup>1</sup> Sent with Message					
	BB	EB	BB/EB	BB/CD	CD	¬BB, ¬EB, ¬CD

**Notes:**

1. Symbols:
  - BB: Begin-Bracket
  - EB: End-Bracket
  - CD: Change-Direction. Allowed on Last- or Only-in-Chain.
  - BB/EB: Begin- and End-Bracket. Allowed on First- or Only-in-Chain.
2. LUSTATUS, CHASE, and CANCEL can indicate EB or CD. For information on these command protocols, see “Data Flow Control Protocol Reference” on page 329. Other VTAM normal flow commands or indicators must not indicate either EB or CD.
 

When IMS is waiting for conversational input, LUSTATUS and CHASE cannot be sent to IMS unless they also indicate end-bracket. EB causes the conversational output message to be dequeued, the conversation mode to be terminated, and the Conversational Abnormal Termination exit routine to be invoked. See the description of LUSTATUS and “Handling IMS Response Mode or Conversational Output Errors” on page 319. The session is terminated if an LUSTATUS or CHASE is received by IMS with any other protocol.
3. FMH7 messages and LUSTATUS NO-OP indicating EB force end of conversation, response mode, and test mode and cause the associated IMS output message to be dequeued. Further, the Conversational Abnormal Termination exit routine is invoked. See the description of LUSTATUS and “Handling IMS Response Mode or Conversational Output Errors” on page 319.

### Bracket Protocol for IMS Output

The output bracket and send/receive protocol used by IMS and the number of output messages sent per bracket depend upon a combination of one or more of the following:

- The IMS message type
- Whether the message is to be MFS paged
- Whether the other half session supports the SCHEDULER model
- The output component specified during IMS system definition
- The bracket and ATTACH protocol associated with the originating input transaction

Within IMS, the protocols used for nonlast chains (pages) of MFS-paged output and the last (MFS-paged) or only chain of response mode, conversation mode, test mode, or command replies are predefined regardless of whether the originating input transaction and resulting output replies are synchronous (ATTACH) or asynchronous (SCHEDULER). This is also true for output resulting from input sent with ATTACH EB and for asynchronous output that must be sent ATTACH because the other half session lacks SCHEDULER support.

CD is used for all nonlast chains of MFS demand-paged messages, the last (MFS-paged) or only chain of test mode, and nonlast conversational mode messages. CD allows the paging operation or synchronous event between IMS and the other half session to continue.

EB ensures that the end of the synchronous event occurs by placing the session in reset state for the last (MFS-paged) or only chain of response mode replies, last conversational mode replies, and command replies. This is also true for replies resulting from input sent with ATTACH EB and for asynchronous output that must

## Bracket and Half-Duplex Protocol

be sent ATTACH because the other half session lacks SCHEDULER support. All nonlast chains (pages) of MFS-autopaged messages are sent without either CD or EB.

Using ATTACH SCHEDULER, your installation must define to IMS the protocols to be used for the last (MFS-paged) or only chain of other asynchronous output. IMS allows you to specify single or multiple messages for each component defined for a session and whether IMS should send more than one asynchronous message before indicating change-direction or end-bracket. The possible component definitions are:

### **SINGLE1**

Asynchronous output for this component is sent one message per bracket. Each message begins a bracket (if necessary) and always ends a bracket.

### **SINGLE2**

Asynchronous output for this component is sent one message at a time with the VTAM begin-bracket (if necessary) and change-direction indicators to allow the receiving subsystem to optionally send its communication traffic.

### **MULT1**

All asynchronous messages for a given LTERM are sent before the bracket is ended. Traffic is sent BB (if necessary), message1, message2,...messageN, EB. EB occurs after the last message for the LTERM is acknowledged and dequeued.

### **MULT2**

All asynchronous messages for a given LTERM are sent before change-direction is sent. Traffic is sent BB (if necessary), message1, message2...messageN, CD. CD occurs after the last message for the LTERM is acknowledged and dequeued.

Consider the definition (on the IMS system definition TERMINAL macro statement or an ETO logon descriptor), and use of protocols for ISC components to be used for transmission of asynchronous messages. This is particularly true in an IMS-to-IMS environment, because most messages between the two subsystems are asynchronous. Incorrectly defining or using these ISC protocols can:

- Require extra transmissions to occur in order to acquire the flow or to end the bracket
- Cause unnecessary bracket contention error recovery operations
- Produce output protocols unacceptable to the receiving subsystem.

A further explanation follows:

### **SINGLE1**

Use of SINGLE1 results in EB on each message and might cause bracket contention if the other subsystem has data to send.

EB on each message can cause process errors within the other subsystem if the transaction must reply synchronously within the initiating bracket. An error of this type can occur in the receiving subsystem when a SINGLE1 component is used to send response mode, conversation, or test mode messages, or IMS commands from one IMS subsystem to another.

### **SINGLE2 or MULT2**

Change-direction sent on messages from a component defined as SINGLE2 might result in unnecessary transmissions to end the bracket when either no output is available or no reply is available within the other subsystem.

**MULT1 or MULT2**

Messages sent on components defined as MULT1 OR MULT2 indicate change-direction or end-bracket only after the last message on a queue has been dequeued. Therefore, extra transmissions might result if the other subsystem must signal for the flow to return synchronous replies.

For components defined as MULT1 and MULT2, IMS suppresses the queue rotation that normally occurs between output messages. This suppression allows all messages from a queue selected for output to be sent before IMS initiates output on other queues. Selection of the next queue with available output occurs when the previous queue has emptied or when input changes the active output queue. The queues are not rotated if an LUSTATUS - queue empty or another input that indicates change-direction occurs for the same queue.

Table 34, Table 35 on page 336, and Table 36 on page 337 summarize the bracket and send/receive indicators that are acceptable for IMS output messages.

*Table 34. Bracket and Send/Receive Indicators for Output Message: Sent Using Attach Scheduler*

Message Type Sent Using Attach Scheduler	VTAM Indicators <sup>1</sup> Sent with Message		
	SINGLE1 msg.init INB BETB	SINGLE2 msg.init INB BETB	MULT1/2 <sup>2</sup> msg.init INB BETB
MFS demand-paged output: First SNA chain (ATTACH SCHEDULER) <sup>3</sup>	EB BB/EB	EB BB/EB	EB BB/EB
MFS demand-paged output: Nonlast page			
MFS demand-paged output: Last page if OLP <sup>4</sup>	CD	CD	CD
MFS demand-paged output: Last page without OLP (See appropriate message type)			
MFS autopaged output: First page	N BB	N BB	N BB
MFS autopaged output: Nonfirst, nonlast page	N	N	N
MFS autopaged output: Last page (See appropriate message type)			
Response mode output (Including Fast Path)	EB	EB	EB
Nonlast conversational output message	CD	CD	CD
Last conversational output message	EB	EB	EB
Message switch output	EB BB/EB	CD BB/CD	N BB
Command output: /FOR, /DIS, /RDIS	EB BB/EB	CD BB/CD	N BB
Command output: /TEST <sup>5</sup>	CD	CD	CD
Other Command output	EB	EB	EB
Test mode output <sup>5</sup>	CD	CD	CD
None of the above message types - asynchronous	EB BB/EB	CD BB/CD	N BB

## Bracket and Half-Duplex Protocol

Table 34. Bracket and Send/Receive Indicators for Output Message: Sent Using Attach Scheduler (continued)

Message Type Sent Using Attach Scheduler	VTAM Indicators <sup>1</sup> Sent with Message		
	SINGLE1 msg.init INB BETB	SINGLE2 msg.init INB BETB	MULT1/2 <sup>2</sup> msg.init INB BETB

**Notes:**

1. Symbols:

- INB** Indicates that synchronous or asynchronous output occurs within the same bracket as the previous input
- BETB** Indicates that IMS initiates output while in a between-brackets state
- BB** Begin-bracket
- EB** End-bracket
- CD** Change-direction (allowed on last- or only-in-chain)
- N** No bracket or send/receive indicators

- 2. LUSTATUS - queue empty is used at the end of a queue to send EB for MULT1 and CD for MULT2. EB is sent when an ERP backout has reset the DFC and ATTACH states to between-brackets and no component 1 (COMPT1) is defined during IMS system definition. Also, the BB indicator in the BETB column occurs only for the first message or MFS page that must initiate an output bracket asynchronously.
- 3. Although IMS is between-brackets after having sent stand-alone ATTACH SCHEDULER for response mode, Fast Path, or conversational demand-paged output, IMS does not accept input until the preceding output is successfully transmitted and dequeued using the appropriate paging requests.
- 4. MFS operator logical paging (OLP) is in effect if the MOD specifies PAGE=YES and autopaged output is not indicated in the MFS system control area (SCA).
- 5. Applies to test "echo" mode only. Not applicable to /TEST MFS.

Table 35. Bracket and Send/Receive Indicators for Output Message: Sent Using ATTACH (no SCHEDULER)

Message Type Sent Using ATTACH (no SCHEDULER)	VTAM Indicators <sup>1</sup> Sent with Message		
	SINGLE1 msg.init INB BETB	SINGLE2 msg.init INB BETB	MULT1/2 <sup>2</sup> msg.init INB BETB
MFS demand-paged output: First SNA chain (ATTACH)	CD	CD	CD
MFS demand-paged output: Nonlast page, last page if OLP <sup>4</sup>	CD	CD	CD
MFS demand-paged output: Last page without OLP (See appropriate message type)			
MFS autopaged output: First page	N	N	N
MFS autopaged output: Nonfirst, nonlast page	N	N	N
MFS autopaged output: Last page (See appropriate message type)			
Response mode output (including Fast Path) <sup>6</sup>	EB	EB	EB
Nonlast conversational message	CD	CD	CD
Last conversational message	EB	EB	EB
Nonresponse, nonconversational output (No SCHEDULER model defined for other half session)	EB BB/EB	EB BB/EB	EB BB/EB
ATTACH SYSMMSG	BB/EB	BB/CD	BB
Command output			
Command output: /TEST <sup>5</sup>	CD	CD	CD

Table 35. Bracket and Send/Receive Indicators for Output Message: Sent Using ATTACH (no SCHEDULER) (continued)

Message Type Sent Using ATTACH (no SCHEDULER)	VTAM Indicators <sup>1</sup> Sent with Message		
	SINGLE1 msg.init INB BETB	SINGLE2 msg.init INB BETB	MULT1/2 <sup>2</sup> msg.init INB BETB
Other command output (except /FOR, /DIS, and /RDIS) <sup>7</sup>	EB	EB	EB
Test mode output <sup>5</sup>	CD	CD	CD

**Notes:**

1. Symbols:

- INB** Indicates that synchronous or asynchronous output occurs within the same bracket as the previous input
- BETB** Indicates that IMS initiates output while in a between-brackets state
- BB** Begin-bracket
- EB** End-bracket
- CD** Change-direction (allowed on last- or only-in-chain)
- N** No bracket or send/receive indicators

- 2. LUSTATUS - queue empty is used at the end of a queue to send EB for MULT1 and CD for MULT2. EB is sent when an ERP backout has reset the DFC and ATTACH states to between-brackets and no component 1 (COMPT1) is defined during IMS system definition. Also, the BB indicator in the BETB column occurs only for the first message or MFS page that must initiate an output bracket asynchronously.
- 3. Although IMS is between-brackets after having sent stand-alone ATTACH SCHEDULER for response mode, Fast Path, or conversational demand-paged output, IMS does not accept input until the preceding output is successfully transmitted and dequeued using the appropriate paging requests.
- 4. MFS operator logical paging (OLP) is in effect if the MOD specifies PAGE=YES and autopaged output is not indicated in the MFS system control area (SCA).
- 5. Applies to test "echo" mode only. Not applicable to /TEST MFS.
- 6. Response mode operation always occurs for input transactions that are directly attached.
- 7. See "LUSTATUS Protocol" on page 343 for more information on /DISPLAY, /RDISPLAY, and /FORMAT command output.

Table 36. Bracket and Send/Receive Indicators for Output Message: Other Output Message Types

Other Output Message Types	VTAM Indicators <sup>1</sup> Sent with Message		
	SINGLE1 msg.init INB BETB	SINGLE2 msg.init INB BETB	MULT1/2 <sup>2</sup> msg.init INB BETB
VTAM command/indicator <sup>3</sup>			
FMH7 (ERP) messages: During conversation	CD	CD	CD
FMH7 (ERP) messages: During test mode	CD	CD	CD
FMH7 (ERP) messages: Other <sup>4</sup>	EB BB/EB	CD BB/CD	Note 5
QSTATUS (QMODEL)	Note 6	Note 6	Note 6

## Bracket and Half-Duplex Protocol

Table 36. Bracket and Send/Receive Indicators for Output Message: Other Output Message Types (continued)

Other Output Message Types	VTAM Indicators <sup>1</sup> Sent with Message		
	SINGLE1 msg.init INB BETB	SINGLE2 msg.init INB BETB	MULT1/2 <sup>2</sup> msg.init INB BETB

**Notes:**

1. Symbols:

- INB** Indicates that synchronous or asynchronous output occurs within the same bracket as the previous input
- BETB** Indicates that IMS initiates output while in a between-brackets state
- BB** Begin-bracket
- EB** End-bracket
- CD** Change-direction (allowed on last- or only-in-chain)
- N** No bracket or send/receive indicators

- 2. LUSTATUS - queue empty is used at the end of a queue to send EB for MULT1 and CD for MULT2. EB is sent when an ERP backout has reset the DFC and ATTACH states to between-brackets and no component 1 (COMPT1) is defined during IMS system definition. Also, the BB indicator in the BETB column occurs only for the first message or MFS page that must initiate an output bracket asynchronously.
- 3. BIS is sent without CD or EB. CHASE is always sent CD. See "LUSTATUS Protocol" on page 343 and "CANCEL Protocol" for the DFC bracket, send/receive, and response requirements for LUSTATUS and CANCEL, respectively.
- 4. An FMH7 requests the protocol associated with the resulting between-brackets reset state of the last committed input component after backout of the DFC and ATTACH states due to the ERP operation.
- 5. FMH7 is sent with EB for MULT1, CD for MULT2.
- 6. CD/RQE1 is sent on a QSTATUS that results from an invalid cursor in an MFS DPM demand-page request for output. CD/RQE2 or EB/RQD2 is sent on QSTATUS, which results from the receipt of QPURGE during demand-paged output. CD/RQE2 is sent: 1) when in IMS conversation or test mode or 2) when the input is sent with ATTACH SCHEDULER and the associated output component was SINGLE2 or MULT2. All other cases result in EB/RQD2.

**Related Reading:** For examples of nonpaged and MFS bracket and half-duplex protocol, see Appendix H, "ISC Data Flow Control Examples," on page 579.

## CANCEL Protocol

IMS sends and receives the SNA CANCEL command. CANCEL allows the sender to terminate an output SNA chain without having to send all of the chain following a sender- or receiver-detected error.

The CANCEL command sent because of either a sender- or receiver-detected error is sent by IMS with the VTAM indicators shown in Table 37.

Table 37. VTAM Indicators Sent with the CANCEL Command

Output (Determined in Following Order)	VTAM Indicators with CANCEL		
	¬CD or ¬EB	CD	EB
After /DEQ (LUSTATUS ABORT is next)	X		
When primary half session and FIC/OIC was between bracket (conditional BB)	X		
After receiving selective receiver ERP sense code		X	
After receiving SIGNAL		X	



Table 37. VTAM Indicators Sent with the CANCEL Command (continued)

Output (Determined in Following Order)	VTAM Indicators with CANCEL		
	¬CD or ¬EB	CD	EB
When conversational or response mode output is still available	X		
FIC/OIC was EB RQD* (conditional EB)			X
While in test (echo) mode		X	
Non-MFS demand-paged output for SINGLE1 component	See indicators for FIC/OIC was between bracket or FIC/OIC was EB		
MFS demand-paged output for SINGLE1 component			X
Output for SINGLE2 component		X	
Output for MULT1 or MULT2 component	X		

The CANCEL command received by IMS because of either a sender- or receiver-detected error can indicate whatever protocol (consistent with current DFC states) is appropriate for the message sender.

## Chaining Protocol

Whether operating as the primary or secondary half session, IMS sends both single and multiple RU chains. Half sessions can operate with either single or multiple RU chains as specified in the bind parameters.

IMS messages are usually sent and received as single SNA chains where only-in-chain (OIC) or first-in-chain (FIC) indicates beginning-of-message, and OIC or last-in-chain (LIC) indicates end-of-message. However, each page of an MFS-paged input or output message is sent or received as a single SNA chain. The beginning-of-message occurs when the first page is sent or received, and the end-of-message occurs at sync point (RQD2 or RQE2, CD) requested at the end of the last input or output page (except for MFS operator logical paging).

Optionally, end-of-message can be requested using LUSTATUS - commit immediately following the last page of MFS DPM-autopaged input.

Use the CANCEL command when errors are detected on multiple RU input chains.

### Related Reading:

- For more information on LUSTATUS - commit, see “LUSTATUS Protocol” on page 343.
- For more information on multichain purging, see “ERP Purging” on page 340.

## CHASE Protocol

IMS sends and receives SNA CHASE. IMS sends CHASE requesting RQE1/CD to cause a synchronizing event after the receipt of an exception response when it is between pages (chains) of MFS-autopaged output and is not bound with Definite Response Chains Only.

IMS responds with DR1, as necessary, when receiving CHASE. IMS can receive CHASE between any two messages within a bracket. IMS can also receive CHASE as a synchronizing event after IMS has sent an exception response to

MFS-autopaged input. (The sender of the MFS-autopaged input receives the exception response while between output pages or after a chain indicating RQE1.)

Only CHASE carrying EB is accepted while IMS is waiting for conversational input. EB causes the conversational output message to be dequeued, conversation mode to be terminated, and the Conversational Abnormal Termination exit routine to be invoked, just as if an /EXIT command had been received. The session is terminated if CHASE is received with any protocol other than EB.

### ERP Purging

After sending an exception response and before continuing to send or receive, the exception response sender might need to enter error recovery process (ERP) PURGE mode until the DFC state managers of both half sessions are synchronized. Additionally, ERP PURGE must be complete prior to sending the FMH7 ERP message. ERP purging can occur for either single or multiple SNA chains. Single chain purge occurs when DFC states are synchronized within the same chain receiving the exception response. Multichain purge occurs when more than a single SNA chain must be purged before the DFC state managers are synchronized. (The CANCEL and CHASE commands are logically considered part of the same chain when they occur immediately after the SNA chain that resulted in the exception response.)

Single- and multiple-chain purging occur within the data flow control support layer and are independent of SNA presentation layer functions such as MFS.

ERP PURGE must be entered when a half session sends an exception response to an RU (OIC, MIC, or LIC) that does not result in ending a bracket or in both half-session DFC states being synchronized. That is, ERP PURGE begins when a half session sends an exception response to the following RUs:

- FIC RQE\* (not applicable for EB)
- MIC RQE\* (not applicable for CD or EB)
- LIC RQE\* -EB and -CD
- OIC RQE\* -EB and -CD

ERP PURGE ends when the purging half session receives an RU that either ends the bracket or causes both half-session DFC states to again be synchronized. That is, ERP PURGE terminates when the purging half session receives the following RUs:

<b>OIC RQD*</b>	This includes the CANCEL and CHASE commands, and is not applicable for CD or EB.
<b>OIC RQE* CD or EB</b>	This includes the CANCEL command.
<b>LIC RQD*</b>	Not applicable for CD or EB.
<b>LIC RQE* CD or EB</b>	

ERP PURGE can span several SNA chains before terminating. When more than one chain is purged, an additional exception response is necessary at the point of bracket termination or DFC state synchronization (except for CANCEL or CHASE commands) to prevent an ambiguous or incorrect understanding as to the disposition of the message by the sending half session (response receiver). This sender ERP exception response (X'0867') indicates that the chain was purged because of an error on a previous chain and that the message sender should resend the message at the next possible opportunity. The X'0867' exception response must

be sent when a half session ends ERP PURGE after receiving the following RUs in a chain subsequent to the one that resulted in the original exception response:

- OIC RQD\*** This does not include CANCEL or CHASE, and is not applicable for CD or EB.
- OIC RQE\* CD or EB** Except for CANCEL
- LIC RQD\*** Not applicable for CD or EB.
- LIC RQE\* CD or EB**

The DFC protocol that can be received with the FMH7 ERP message must be either change-direction or end-bracket and can include begin-bracket, as appropriate. The DFC protocol (CD or EB) that is sent by IMS with the FMH7 ERP message is determined by the ATTDSP value resulting after ERP backout. When backout results in a between-brackets state, the ATTDSP value is component 1. When backout results in a state other than between-brackets, the ATTDSP value is the last committed input component. The protocols are set for the resulting component. End-bracket is sent when an ERP backout has reset the DFC and ATTACH states to between-brackets and no component 1 (COMPT1) was defined during IMS system definition.

**Related Reading:** For information on the protocols that are set for the resulting component, see “Bracket Protocol for IMS Output” on page 333.

### Resulting DFC State after Sender ERP Purge

Table 38 reflects all valid bracket and send/receive states that result after both half sessions reach a sync point after an exception response that indicates a sender ERP sense code other than selective receiver ERP.

Table 38. Resulting DFC States after Sender ERP Purge

Type of Chain in Error	PHS Sends Data, SHS Sends Exception: Half-Session States		SHS Sends Data, PHS Sends Exception: Half-Session States	
	PHS	SHS	PHS	SHS
BB/— FIC				
RQ** CD OIC,LIC	1	1	INB.SEND	INB.RCV
RQD* OIC,LIC	BETB	BETB	INB.RCV	INB.SEND
RQD* CANCEL	BETB	BETB	INB.RCV	INB.SEND
RQ** CD CANCEL	1	1	INB.SEND	INB.RCV
RQD* EB CANCEL	1	1	BETB	BETB
BB/EB FIC				
RQE* OIC,LIC	BETB	BETB	BETB	BETB
RQD* OIC,LIC	BETB	BETB	BETB	BETB
RQD* CANCEL	BETB	BETB	BETB	BETB
RQ** CD CANCEL <sup>1</sup>				
RQD* EB CANCEL <sup>1</sup>				
--/-- FIC				
RQE* OIC,LIC	INB.SEND	INB.RCV	INB.RCV	INB.SEND
RQ** CD OIC,LIC	INB.RCV	INB.SEND	INB.SEND	INB.RCV
RQD* OIC,LIC	INB.SEND	INB.RCV	INB.RCV	INB.SEND

Table 38. Resulting DFC States after Sender ERP Purge (continued)

Type of Chain in Error	PHS Sends Data, SHS Sends Exception: Half-Session States		SHS Sends Data, PHS Sends Exception: Half-Session States	
	PHS	SHS	PHS	SHS
RQD* CANCEL	INB.SEND	INB.RCV	INB.RCV	INB.SEND
RQ** CD CANCEL	INB.RCV	INB.SEND	INB.SEND	INB.RCV
RQD* EB CANCEL	BETB	BETB	BETB	BETB
--/EB FIC				
RQ** CD OIC,LIC	INB.RCV	INB.SEND	INB.SEND	INB.RCV
RQD* OIC,LIC	INB.SEND	INB.RCV	INB.RCV	INB.SEND
RQD* CANCEL	INB.SEND	INB.RCV	INB.RCV	INB.SEND
RQ** CD CANCEL	INB.RCV	INB.SEND	INB.SEND	INB.RCV
RQD* EB CANCEL	BETB	BETB	BETB	BETB

**Where:**

- BETB: between-brackets
- INB : in-brackets
- PHS : primary half session
- SHS : secondary half session

<sup>1</sup>CD and EB might not be sent while in DFC BETB state.

**Resulting DFC State after Selective Receiver ERP Purge**

Table 39 reflects all valid bracket and send/receive states that result after both half sessions reach a sync point after an exception response that indicates the SNA selective receiver ERP sense code, and before the FMH7 is sent by the half session detecting the error.

Table 39. Resulting DFC States after Selective Receiver ERP Purge

Type of Chain in Error	PHS Sends Data, SHS Sends Exception: Half-Session States		SHS Sends Data, PHS Sends Exception: Half-Session States	
	PHS	SHS	PHS	SHS
BB/-- FIC				
RQ** CD OIC,LIC	1	1	INB.SEND	INB.RCV
RQD* OIC,LIC	ERP.RCV	ERP.SEND	INB.SEND	INB.RCV
RQD* CANCEL	ERP.RCV	ERP.SEND	INB.SEND	INB.RCV
RQ** CD CANCEL	1	1	INB.SEND	INB.RCV
RQD* EB CANCEL	1	1	ERP.SEND	ERP.RCV
BB/EB FIC				
RQE* OIC,LIC	ERP.RCV	ERP.SEND	ERP.SEND	ERP.SEND
RQD* OIC,LIC	ERP.RCV	ERP.SEND	ERP.SEND	ERP.SEND
RQD* CANCEL	ERP.RCV	ERP.SEND	ERP.SEND	ERP.SEND
RQ** CD CANCEL <sup>1</sup>				
RQD* EB CANCEL <sup>1</sup>				
--/-- FIC				
RQE* OIC,LIC	INB.RCV	INB.SEND	INB.SEND	INB.RCV

Table 39. Resulting DFC States after Selective Receiver ERP Purge (continued)

Type of Chain in Error	PHS Sends Data, SHS Sends Exception: Half-Session States		SHS Sends Data, PHS Sends Exception: Half-Session States	
	PHS	SHS	PHS	SHS
RQ** CD OIC,LIC	INB.RCV	INB.SEND	INB.SEND	INB.RCV
RQD* OIC,LIC	INB.RCV	INB.SEND	INB.SEND	INB.RCV
RQD* CANCEL	INB.RCV	INB.SEND	INB.SEND	INB.RCV
RQ** CD CANCEL	INB.RCV	INB.SEND	INB.SEND	INB.RCV
RQD* EB CANCEL	ERP.RCV	ERP.SEND	ERP.SEND	ERP.RCV
--/EB FIC				
RQ** CD OIC,LIC	INB.RCV	INB.SEND	INB.SEND	INB.RCV
RQD* OIC,LIC	INB.RCV	INB.SEND	INB.SEND	INB.RCV
RQD* CANCEL	INB.RCV	INB.SEND	INB.SEND	INB.RCV
RQ** CD CANCEL	INB.RCV	INB.SEND	INB.SEND	INB.RCV
RQD* EB CANCEL	ERP.RCV	ERP.SEND	ERP.SEND	ERP.RCV

**Note:** <sup>1</sup> CD and EB cannot be sent while in between-brackets state

## LUSTATUS Protocol

IMS sends and receives LUSTATUS as summarized in Table 40. The DFC bracket, send/receive, and response requirements illustrated in this figure are subject to the considerations detailed in the balance of this topic.

Any LUSTATUS sense code not listed in Table 40 causes the ISC session to be terminated. An S in table 37 indicates the suggested indicator settings for the given LUSTATUS. An X in Table 37 indicates that IMS also supports the specified indicator settings for the given LUSTATUS.

Table 40. VTAM Indicators Sent with LUSTATUS

LUSTATUS	VTAM Indicators with LUSTATUS								
	RQE1		RQD1			RQE2	RQD2		
	EB	CD	--	CD	EB	CD	--	CD	EB
Sense Code Received <sup>1</sup> : Commit-X'0006'						S	S	X	S
Sense Code Received <sup>1</sup> : NO-OP-X'0006'	X	S		X	S				
Sense Code Received <sup>1</sup> : Queue Empty-X'0007'		S		X	S				
Function Abort-X'0864'		S	S	X	S				
Function Abort-X'0865'		S	S	X	S				
Function Abort-X'0866'		X	X	X	X				
Sense Codes Sent: Commit-X'0006'									

Table 40. VTAM Indicators Sent with LUSTATUS (continued)

LUSTATUS	VTAM Indicators with LUSTATUS								
	RQE1		RQD1			RQE2	RQD2		
	EB	CD	--	CD	EB	CD	--	CD	EB
Sense Codes Sent: NO-OP-X'0006'		X			X				
Sense Codes Sent: Queue Empty-X'0007'		X			X				
Function Abort -X'0865'		X	X		X				

**Notes:**

1. While IMS is waiting for conversational input, it accepts LUSTATUS carrying EB only. EB causes the conversational output message to be dequeued, conversation mode to be terminated, and the Conversational Abnormal Termination exit routine to be scheduled. The session is terminated if an LUSTATUS carrying any other protocol is received.

IMS responds DR1 or DR2 when receiving LUSTATUS RQD1 or RQD2. IMS requests DR1, DR2, or exception DR1 or DR2 as indicated in Table 40 on page 343. The session is terminated if an exception occurs to LUSTATUS.

- LUSTATUS - Queue Empty.

IMS sends and receives LUSTATUS - queue empty.

IMS sends LUSTATUS - queue empty:

- After receiving an asynchronous (ATTACH SCHEDULER) input message and having no output immediately available.
- After sending all available output on a given queue.

RQD1 and end-bracket are indicated on the LUSTATUS sent when IMS is not in conversation or response mode and has been left in-brackets/SEND, and no output is available to be sent from a component defined as SINGLE1 or MULT1. RQE1 and change-direction are indicated on the LUSTATUS sent when IMS is not in conversation or response mode and has been left in-brackets/SEND, and no output is available to be sent from a component defined as SINGLE2 or MULT2.

- LUSTATUS - Function Abort. The supported sense codes are:

**X'0864'**

Loop occurs upon re-execution. Sender should not resend the same data.

**X'0865'**

Data sender is responsible for detecting and preventing loop.

**X'0866'**

Data receiver is responsible for detecting and preventing loop.

IMS sends LUSTATUS - function abortX'0865' only under these conditions:

- When an IMS /DEQUEUE command has been issued by an authorized IMS terminal operator before the last page of an MFS-demand or autopaged output message has been sent by IMS.

The DFC bracket and send/receive protocol indicated on the LUSTATUS is the same as that which would occur with the last chain (page) had the message been successfully sent.

The following occurs when IMS receives LUSTATUS - function abort:

- Except during conversational mode, any function abort received after an output message (including the last page of MFS demand-paged or autopaged

output) sent RQE/CD causes the output message to be committed and does not cause session termination. LUSTATUS that is processed as a normal flow input before it is processed as an LUSTATUS command also causes the message to be committed.

- Any function abort causes an incomplete input MFS-autopaged message to be discarded.
- Function abort X'0864', received before the last page of an output MFS demand-paged message is sent, causes the message to be dequeued prior to continuing normal input/output operations if the output is conversational and demand-paged. The Conversational Abnormal Termination exit routine is invoked, just as if an /EXIT command had been received on the session.
- Function abort X'0865', received before the last page of an active output MFS demand-paged message is sent, causes the message to be returned to the output message queue and the session to be terminated.
- Function abort X'0866', received before the last page of an active output MFS demand-paged message, causes the message to be returned to the message queue and made available for retransmission before normal input/output operations continue.
- Any function abort resets the ATTACH states to those in effect at the last sync point.

LUSTATUS - function abort might never be sent to IMS in reply to any RU indicating RQD2 or RQE2, or the session is terminated.

- LUSTATUS - Commit

IMS does not send LUSTATUS - commit. IMS receives LUSTATUS - commit as an end-of-message indication immediately following the last page of autopaged input and with EB while awaiting conversational input. This creates a "normal" end of the conversation by invoking the Conversational Abnormal Termination exit routine with a new input vector of X'28'. This allows the exit routine to schedule a transaction to commit pending resources reflected in the scratch pad area (SPA).

**Related Reading:** For more information on normal and abnormal termination of conversations, see "Handling IMS Response Mode or Conversational Output Errors" on page 319.

- LUSTATUS - NO-OP

IMS sends and receives LUSTATUS - NO-OP.

IMS sends LUSTATUS - NO-OP:

- To allow RQE1 and change-direction (CD) to flow after SIGNAL RCD.
- To end the bracket after receiving a synchronous input message that generates no output. In IMS, this only occurs for the FORMAT, /RDISPLAY, and /DISPLAY commands when attached synchronously. The LUSTATUS - NO-OP is sent indicating RQD1 and EB.
- To end the bracket at those times when bound in-brackets/SEND and no synchronous output or restart is possible. That is, IMS is not in conversation or response mode after session restart. The LUSTATUS is sent, indicating RQD1 and EB.
- To allow required input when bound in-brackets/SEND at session restart and a pending conversational message is dequeued using STSN protocol. LUSTATUS is sent indicating RQE1 and CD.
- To end the bracket after receiving exception or ERP FMH7 (without EB) sense code X'0864', following response mode or the last output message of an IMS conversation.

## LUSTATUS Protocol

LUSTATUS - NO-OP can be received during asynchronous or synchronous input processing and might indicate either CD or EB, as necessary. Receipt of LUSTATUS EB during an IMS conversation or response mode or while in test mode causes termination of the IMS conversation, response, or test mode and causes the associated output message to be dequeued. For conversation, the Conversational Abnormal Termination exit routine is invoked just as if an /EXIT command had been received.

When IMS is the secondary half session, it receives a special case of LUSTATUS BB/EB RQ\*1 after responding with DR1 to a BID command sent by the primary half session. This LUSTATUS removes IMS (secondary) from a DFC in-brackets/pending state that was set after the aforementioned DR1 was sent and the primary half session has no other message available to be sent. This condition might occur when, for example, the application within the primary half session that caused the BID to be sent might have been abnormally terminated during the time between sending the BID and receiving the BID response.

LUSTATUS-CD should not be followed by another LUSTATUS-CD. Doing so creates a back-and-forth effect between the half sessions. IMS always responds LUSTATUS-EB when receiving LUSTATUS-CD and no output is available to be sent.

### Paged Messages ERP

For sender-detected errors (/DEQ command) detected after transmission of an IMS multichain demand or autopaged output message has been initiated, IMS must send the CANCEL command (as necessary) in conjunction with LUSTATUS - abort. The CANCEL command is used to terminate a single multi-RU chain, or page, while the LUSTATUS is used to terminate the process receiving the multichain, or paged, message. If IMS receives a CANCEL during an input autopaged message without receiving the subsequent LUSTATUS - abort on the next input RU, IMS returns an exception response indicating selective receiver ERP followed by an FMH7 with the abort sense code X'0865' and an appropriate ERP message. Only the LUSTATUS - abort need be sent or received when the error is detected while between chains.

Errors detected on the first page of an autopaged input message result in IMS either sending a contention sense code or a selective receiver ERP sense code followed by an FMH7 indicating one of the nonfunction abort sense codes and an appropriate error message. Errors detected on nonfirst pages of an autopaged input message or for input page request received during an IMS demand-paged output message result in IMS sending the selective receiver ERP sense code followed by an FMH7 indicating the X'08650000' function abort sense code and an appropriate error message. The function abort sense code is used in these cases to cause the sending process (of autopaged input or demand-paged requests), rather than just a single chain or page, to be terminated.

### Ready-to-Receive Protocol

IMS does not send the SNA ready-to-receive (RTR) command, but receives the command when acting as a primary half session.

When receiving the RTR command, IMS responds either with a DR1, followed by an available output message, or with an exception DR1 response (X'08190000'), if output is either not available or cannot be sent.



## RSHUT Protocol

IMS does not send, but does receive, the RSHUT command. When receiving RSHUT, IMS sends a DR1 response and schedules termination of the session at the next convenient point. The session is normally terminated at the end of the current input or output chain.

### Selective Receiver ERP

Selective receiver error recovery procedure (ERP) is initiated using the X'08460000' sender ERP sense code. The procedure has these characteristics:

- The procedure is symmetrical to both half sessions.
- ERP messages can be sent by the sender of the exception response indicating selective receiver ERP. An ERP message is an ERP FMH7 header followed by an IMS error message. Each selective receiver ERP message is preceded by an ERP FMH7 function management header.
- Contention for ERP messages does not occur for the exception response sender.
- ERP messages can consist of a full chain of arbitrary length, but must immediately follow the exception response indicating selective receiver ERP.
- The ERP message is recognized by the receiver for special processing.
- The response sender has an opportunity to reset the function management level bracket and send/receive states.

The ERP messages sent by IMS have associated default IMS message output descriptors (MODs) and display output formats (DOFs). The error message is formatted using SNA character string (SCS) controls even when sent to a component defined with MFS.

**Related Reading:** For more information on SNA character sets, see Appendix E, "SNA Character String Controls," on page 523.

If necessary, the sender of the exception response enters into an ERP PURGE mode until both half sessions' send/receive states are again synchronized. The receiver of the exception response must cause the resynchronizing event.

#### **Related Reading:**

- For information on the ERP FMH7 function management header, see "Error Recovery Procedure FM Header" on page 359.
- For information on the ERP PURGE mode, see "ERP Purging" on page 340.
- For information on the resynchronizing event that the receiver of the exception response must start, see "Sender ERP" on page 351.

### Selective Receiver ERP Sense Codes Supported

During output, IMS recognizes receipt of the SNA-defined selective receiver ERP system sense code when assuming either half-session role, returns the message to the queue, ensures that a synchronizing event occurs to end the other half session's ERP purge cycle, and enters a receive state that can be satisfied only by input (ERP message) from the other half session.

When receiving this ERP message, IMS takes one of three actions based on the FMH7 sense code and the DFC protocols associated with the received ERP message:

- The ERP message (DFS2083) is routed to the IMS master terminal operator as a warning that an error condition was recovered on the ISC session. The ISC output message in error is either dequeued or retransmitted, and normal input

## Selective Receiver ERP

or output operations continue. The message is retransmitted when an FMH7 is received with sense code X'0866' and without EB. The message is dequeued when an FMH7 is received with EB during test, response, or conversational mode output.

- The ERP message (DFS2073) is routed to the IMS LTERM associated with the IMS terminal operator who was the source (using an IMS message switch) of the ISC message switch output in error. The ISC output message in error is dequeued and normal input or output operations continue.
- The ERP message (DFS2073) is routed to the IMS master terminal operator and the ISC session is terminated. The ISC output message in error remains on the IMS message queue.

All ERP messages must carry an EB or CD or the session is terminated. Further, EB received with the ERP message forces end of IMS conversation, response, or test mode. When conversation mode is terminated, the Conversation Abnormal Termination exit routine is also invoked as would occur when an IMS /EXIT command is received. IMS processes FMH7 ERP messages received based on the FMH7 sense code and the DFC protocols associated with the message as in these subtopics.

### X'0864xxxx'—Function Abort

The loop occurs upon retransmission. The sender should not resend the data. Table 41 shows how IMS processes the FMH7 ERP messages with sense code X'0864xxxx'.

Table 41. IMS Processing for Sense Code X'0864xxxx'

Message Type	MTO DFS2083	MTO DFS2073	TERMINAL DFS2073
Response mode			
FMH7 W/EB	X		
FMH7 W/CD <sup>1</sup>	X		
Non-last conversation			
FMH7 W/EB <sup>2</sup>	X		
FMH7 W/CD		X	
Last conversation			
FMH7 W/EB <sup>2</sup>	X		
FMH7 W/CD <sup>1, 2</sup>	X		
Message switch			X
Test mode			
FMH7 W/EB	X		
FMH7 W/CD		X	
Other Message Types			
FMH7 W/EB	X		
FMH7 W/CD <sup>1</sup>	X		

#### Notes:

1. FMH7 received with CD schedules LUSTATUS-NO-OP (X'0006') with EB to be returned next on the session if the output in error was a response mode reply, the last conversational output, or an ATTACH without SCHEDULER.
2. Conversation Abnormal Termination exit routine is invoked as would occur for /EXIT.

### X'0865xxxx'—Function Abort

The sender is responsible for detecting the loop. Table 42 shows how IMS processes the FMH7 ERP messages with sense code X'0865xxxx'.

Table 42. IMS Processing for Sense Code X'0865xxxx'

Message Type	MTO DFS2083	MTO DFS2073	TERMINAL DFS2073
Response mode			
FMH7 W/EB	X		
FMH7 W/CD		X	
Non-last conversation			
FMH7 W/EB <sup>1</sup>	X		
FMH7 W/CD		X	
Last conversation			
FMH7 W/EB <sup>1</sup>	X		
FMH7 W/CD		X	
Message switch			X
Test mode			
FMH7 W/EB	X		
FMH7 W/CD		X	
Other Message Types			
FMH7 W/EB		X	
FMH7 W/CD		X	

**Notes:**

1. Conversation Abnormal Termination exit routine is invoked as would occur for /EXIT.

### X'0866xxxx'—Function Abort

The receiver is responsible for detecting the loop. Table 43 shows how IMS processes the FMH7 ERP messages with sense code X'0866xxxx'.

Table 43. IMS Processing for Sense Code X'0866xxxx'

Message Type	MTO DFS2083	MTO DFS2073	TERMINAL DFS2073
Response mode			
FMH7 W/EB	X		
FMH7 W/CD	X		
Non-last conversation			
FMH7 W/EB <sup>2</sup>	X		
FMH7 W/CD	X		
Last conversation			
FMH7 W/EB <sup>2</sup>	X		
FMH7 W/CD	X		
Message switch	X		
Test mode			
FMH7 W/EB	X		

## Selective Receiver ERP

Table 43. IMS Processing for Sense Code X'0866xxxx' (continued)

Message Type	MTO DFS2083	MTO DFS2073	TERMINAL DFS2073
FMH7 W/CD		X	
Other Message Types			
FMH7 W/EB	X		
FMH7 W/CD <sup>1</sup>	X		

**Notes:**

1. FMH7 received with CD schedules LUSTATUS-NO-OP (X'0006') with EB to be returned next on the session if the output in error was a response mode reply, the last conversational output, or an ATTACH without SCHEDULER.
2. Conversation Abnormal Termination exit routine is invoked as would occur for /EXIT.

During input, IMS can detect many types of input errors and internal processing conditions, such as undefined transaction codes, incorrect transaction formats, security violations, SNA protocol and data structure errors, and sync-point request errors. These errors can occur on almost any SNA request element of the message and might result in IMS sending an exception response indicating a selective receiver ERP sense code; purging the input message until a synchronizing CANCEL command, RQD1 or RQD2, change-direction indicator, or CHASE command is received; and then sending a selective receiver ERP message.

IMS provides the following sense information in the ERP FMH7 sent with the ERP message:

X'08260000'	Used for input and internal processing errors, other than the errors described in the remainder of this list, that are detected where a normal IMS ERP message is sent.
X'10030000'	Sent when the ATTACH ATTPRN value is not known to IMS.
X'08650000'	A function abort sense code for which the data sender is responsible for detecting and preventing loops. Function abort X'08650000' is sent by IMS after receiving an unsolicited CANCEL command (sender-detected error) during an MFS-autopaged input message that does not result in a DFC between-brackets state. Function abort X'08650000' is also sent by IMS for errors detected on input page requests received during an IMS demand-page output message and for errors detected on nonfirst pages of an autopaged input message.  <b>Related Reading:</b> For more information on X'08650000', see "Paged Messages ERP" on page 346.
X'084B0000'	Sent when the attach ATTDPN value is not available for the component entering the data. That is, the input DPN value was not ISCEDT, the optional ISC edit alias, or basic edit; or MFS was not available for the component. However, if MFS was available but the DPN value was not a valid MID, sense code X'08260000' occurs rather than X'084B0000'.
X'080F0000'	Sent when the ATTACH data stream profile (DSP) value does not define a valid or defined component number for the half-session name within IMS.
X'1008xxxx'	The user field (xxxx) is defined by SNA as follows:

- X'6001'—Invalid ATTACH FM header ATTDDBA value
- X'1204'—Invalid version ID on FMH4

Other types of errors detected during input or output operations that cause immediate session termination are:

- Bracket protocol violations
- Send/receive protocol violations
- Unsupported response requests
- Unsupported or invalid FMH types and formats
- Other major VTAM-detected errors or conditions such as LOSTERM, buffer pool or copy RPL space exhausted, or input RU truncation.

### Receiver-Detected Errors during Data Flow Reset State

The following sense codes can be sent and received when the session flow is not in data flow active state, as, for example, during bind, resynchronization (STSN), or start data traffic (SDT):

X'0845xxxx'	Bind rejected because of invalid user data.
X'0847xxxx'	Restart mode mismatch detected by secondary half session at receipt of BIND1 STSN or SDT.
X'08210000'	Bind rejected because of invalid session parameters.
X'080Dxxxx'	Bind rejected because of bind race.

**Related Reading:** For more information on bind race winner determination, see “Resolving a Bind Race” on page 304.

## Sender ERP

**Related Reading:** For more information on sender error recovery procedure (ERP), see *Systems Network Architecture Format and Protocol Reference: Architectural Logic*.

The SNA CANCEL command can be used during sender error recovery processing as necessary to terminate the chain in error and to provide synchronization between half sessions. CANCEL can be either solicited (by the sender of the exception response) or unsolicited (because of a receiver-detected error, which results in an exception response).

If necessary during chain RU or autopaged output, the sender of the exception response enters into an ERP PURGE mode until both half sessions' send/receive states are again synchronized. The receiver of the exception response must cause the resynchronizing event. This event can be one of the following:

- An RQD1 or RQD2
- Receipt of change-direction
- A CANCEL command (caused by either RQD1 or RQE1/CD), if the exception response occurs during an output chain
- A CHASE command (because of RQD1 on CHASE), if the exception response is received while IMS is between RQE1 output chains (pages) of an autopaged output message

### Sender ERP Sense Codes

The only sender ERP sense codes sent between two IMS subsystems are X'08130000' and X'0846xxxx'.

## Sender ERP

The valid contention sense codes received by IMS and additional operations performed are:

- X'08130000'—Bracket reject; no RTR sent  
No ready-to-receive (RTR) condition is set. When the pseudo-wait is satisfied, the message is retransmitted from the beginning. This sense code can also be used to reject the SNA BIS command sent by IMS.
- X'08140000'—Bracket reject; RTR sent  
The message is returned to the queue, and an RTR pending state is entered. No output is sent while IMS is between-brackets until an RTR is received. However, messages flow, subject to the bracket and send/receive protocol defined for the message type or component, when IMS is again left in an in-brackets/SEND state following receipt of change-direction.

After either of these sense codes, IMS attempts to send the output message.

IMS recognizes receipt of contention system sense code X'08130000' when assuming a primary half-session role, returns the output message to the message queue, and enters a pseudo-receive state that can be satisfied by:

- Receiving input from the secondary half session
- Being posted for output as a result of an IMS master terminal operator command, a message switch from another logical unit, or additional messages inserted by an IMS application program

After either of these actions, IMS attempts to send the output message.

IMS only indicates contention when assuming a secondary half-session role and receiving either input data or normal flow commands (BID and BIS) after having already initiated a bracket to the primary half session. IMS sends the X'08130000' sense code to indicate contention in these cases. The X'08140000' contention sense code is not sent by IMS.

Additional exception response sender ERP sense codes sent and received are:

- X'08190000'—No output available  
This code is sent by IMS when assuming the primary half-session role and no output is immediately available following receipt of a ready-to-receive (RTR) indicator. IMS does not receive this sense code because IMS does not send RTR.
- X'0846xxxx'—Selective Receiver ERP  
IMS sends and receives the SNA selective receiver ERP sense code. IMS sends this sense code when a response mode, conversational transaction, or application abnormally terminates. xxxx is a user sense field that is ignored by IMS when it is received. However, IMS does include this sense code in the message that is sent to the master terminal or to the terminal operator that was the source of the message. During output, it is normally set to the binary value of the IMS error message number that is sent as the ERP message when sending the response. However, the user sense code can be set to X'0000' as, for example, when the error, such as an application abend, occurs for a response mode or conversational transaction.

### **Related Reading:**

- For information on how IMS sends and receives the SNA selective receiver ERP sense code, see “Selective Receiver ERP” on page 347.
- For more information on this sense code, see *IMS Version 9: Messages and Codes, Volume 1*.

- X'0864xxxx'—Function abort. Loop occurs upon retransmission. Sender should not resend data.  
IMS receives, but does not send, this function abort sense code. When receiving this code, IMS dequeues the associated output message (if still active) and then continues with normal input or output operations. xxxx is a user sense field ignored by IMS. An LUSTATUS - abort is sent by IMS if input is received prior to the end of an IMS MFS-paged output message.  
The function abort sense code X'0864xxxx' cannot be sent to IMS during nonlast IMS conversational output; otherwise, the output message is returned to the queue. The master terminal operator is notified and the session is terminated. When the function abort sense code X'0864xxxx' is sent following the last conversational output message, the message is dequeued and the Conversational Abnormal Termination exit routine is invoked just as occurs for /EXIT.
- X'0865xxxx'—Function abort. Sender responsible to detect loop.  
IMS receives, but does not send, the sender ERP abort sense code. If received, this code causes IMS to return a message to the queue and close the session. IMS retransmits the message from the beginning at the next opportunity after session restart. xxxx is a user sense field ignored by IMS.
- X'0866xxxx'—Function abort. Receiver responsible to detect loop.  
This sense code causes IMS to retransmit the message from the beginning at the next opportunity. The session is not terminated. xxxx is a user sense field ignored by IMS.
- X'08670000'—Multichain ERP purge.  
IMS sends the multichain purge sense code at the end of ERP purging, as defined under “ERP Purging” on page 340. IMS receives the multichain ERP purge sense code only after receiving an exception response to a nonfirst or nonlast page of an MFS output autopaged message. Non-MFS autopaged output and the first and last page of an MFS output autopaged message are sent requesting definite response. Exception to these SNA chains can result only in single chain purge.

Other sender ERP sense codes cause IMS to notify the master terminal operator and terminate the session.

### Sender-Detected Errors on Nonpaged Messages

When an error is detected after initiating transmission of a single SNA nonpaged, multi-RU message, the sender can send the SNA unsolicited CANCEL command. IMS sends unsolicited CANCEL only if a current output message is terminated by an operator /DEQUEUE command entered prior to the last segment of the message (single SNA chain) being transmitted.

If IMS receives an unsolicited CANCEL while data is being received by IMS, the message is discarded or backed out.

## Sense Codes that IMS Receives

**Definition:** A *sense code* is a 2-byte field containing the category and modifier defined for the particular exception condition that has occurred. The 2 bytes following the sense code can contain optional user data, and are not supported for all sense codes. Table 44 on page 354 shows the input sense codes that IMS receives.

## Sense Codes that IMS Receives

Table 44. Sense Codes that IMS Receives

Input Sense Code Name	Input Sense Code	Sender ERP	FMH7	LUSTATUS
Commit/NO-OP	- X'00060000'			X
Queue empty	- X'00070000'			X
Bind race	- X'080D0000'	X		
Contention	- X'08130000'	X		
Contention	- X'08140000'	X		
Invalid parms	- X'08210000'	X		
Sel Rcvr ERP	- X'08460000'	X		
Reject restart	- X'08470000'	X		
Abort	- X'08640000'	X	X	X
Abort	- X'08650000'	X	X	X
Abort	- X'08660000'	X	X	X
ERP purge	- X'0867'	X		
Other		Note 1	Note 1	Note 1

### Notes:

1. Other sense codes cause IMS to notify the master terminal operator and terminate the session.

**Related Reading:** For more information on sense codes, see *Systems Network Architecture Format and Protocol Reference: Architectural Logic*.

## Sense Codes that IMS Sends

Table 45 shows the output sense codes that IMS sends.

Table 45. Sense Codes that IMS Sends

Output Sense Code Name	Output Sense Code	Sender ERP	FMH7	LUSTATUS
NO-OP	- X'00060000'			X
Queue empty	- X'00070000'			X
Bind race	- X'080D0000'	X		
ATTDSP	- X'080F0000'		X	
Contention	- X'08130000'	X		
No output	- X'08190000'	X		
Invalid parms	- X'08210000'	X		
Not supported	- X'08260000'		X	
Sel Rcvr ERP	- X'08460000'	X		
Reject restart	- X'08470000'	X		
ATTPDN	- X'084B0000'		X	
Abort	- X'08650000'	X		X
ERP purge	- X'0867'	X		
ATTPRN	- X'10030000'		X	
FMH4 Version ID	- X'10081204'		X	



Table 45. Sense Codes that IMS Sends (continued)

Output Sense Code Name	Output Sense Code	Sender ERP	FMH7	LUSTATUS
ATTDBA	- X'10086001'		X	

## SIGNAL Protocol

IMS sends the SIGNAL command to request change-direction (SIGNAL RCD - X'00010000') at the end of an input message chain that does not indicate change-direction and that produces output that must be sent prior to subsequent input. For example, IMS replies to input commands, response mode transactions, conversational transactions, or input while in test mode. SIGNAL RCD is sent before IMS sends any required DR1 or DR2 response for the input message.

Based on the IMS response protocol and the point at which IMS sends SIGNAL RCD, IMS requires that the next input following SIGNAL RCD be either LUSTATUS or CHASE indicating CD or EB. If neither of these is received by IMS, the session is terminated. Change-direction allows IMS to send the pending output message; end-bracket causes the message to be dequeued and the conversation mode, response mode, or test mode to be terminated. No other input can be processed until the pending output message has been successfully transmitted or dequeued.

After receiving SIGNAL RCD while in bracket state, IMS sends change-direction either at the end of the current output message or immediately on receipt of an LUSTATUS. A SIGNAL RCD received while between brackets prevents IMS from sending further output messages until normal flow input (data or SNA command) occurs.

**Related Reading:** For an example of using SIGNAL RCD, see “Signal Protocol Example” on page 586.

## Symmetrical Session Shutdown for LU 6.1 (SBI and BIS)

Two data flow control commands — stop bracket initiation (SBI) and bracket initiation stopped (BIS)—allow a symmetrical and orderly termination for peer level LU 6.1 half sessions. SBI is a VTAM-expedited flow command, and BIS is a normal flow command.

These commands control only the normal flow requests that initiate new brackets. They do not preclude replies that can flow within existing brackets. Either half session can send SBI at any time to request the receiving half session to suppress future initiation of a bracket. After the receiver of the SBI reaches a point between brackets that is acceptable for shutdown, the receiver returns the BIS command to the SBI initiator. The BIS sender then enters a “no begin-bracket” or “NOBB” state, during which that half session can receive bracket initiation requests and may send requests or replies in the normal flow when in-brackets, but cannot initiate a bracket on its own. The primary half session is responsible for detecting and resolving SBI race conditions by maintaining indications of which half session is in NOBB state and terminating the session if both half sessions reach this state.

A successful completion of a shutdown sequence refers to successful entry into the NOBB state by both half sessions— that is, normal session termination.

IMS sends the SBI command either when the IMS /QUIESCE command is entered or when the quiesce option is specified on the /CHECKPOINT command. When BIS is

## Symmetrical Session Shutdown for LU 6.1 (SBI and BIS)

returned from the other subsystem, IMS continues with the QUIESCE or CHECKPOINT command process. If the /QUIESCE command was entered and a CHECKPOINT QUIESCE is not in progress, IMS sends BIS at the next transition to a between-brackets state. If a CHECKPOINT QUIESCE is in progress when IMS receives BIS, IMS continues to send output according to other /CHECKPOINT parameters (FREEZE, PURGE, and DUMPQ) and then sends BIS when the shutdown process is complete.

After receiving an SBI or BIS, IMS sends BIS at the next between-brackets state when a CHECKPOINT QUIESCE is not in progress, or at the end of the shutdown process when a CHECKPOINT QUIESCE is in progress.

When IMS is the primary half session, IMS checks after either sending or receiving BIS to ensure that both half sessions are in NOBB state. If both are, IMS resets all message counts and terminates the session. Otherwise, IMS continues with normal processing. When IMS is the secondary half session, IMS waits for the primary half session to terminate the session. If an LTERM subpool is allocated to the session, it is deallocated (and associated message counts are reset) prior to the session termination when both half sessions are in NOBB state. This deallocation/termination process allows a subsequent cold start of the session and frees any allocated subpools for use by other sessions. This process also ensures that no resynchronization or recovery is required when the session is restarted.

Because initiating a bracket is not allowed after the NOBB state is entered, a problem occurs when a single-bracket-chain (begin- and end-bracket) input message requires an immediate reply (such as a system or error message) that initiates a bracket. Rather than preclude end-bracket on these input messages while in NOBB state, IMS accepts and continues to process all input. When a reply occurs that would require IMS to initiate a bracket while in NOBB state, the session is terminated.

While IMS is in response mode, in conversational mode, or waiting for a Fast Path response, subpool deallocation cannot occur nor can BIS be sent, because no EB has flowed either on output or input (that is, IMS is not between-brackets).

**Related Reading:** For examples of SBI/BIS protocol, see “SBI/BIS Examples” on page 585.

---

## Function Management Headers

In SNA, function management (FM) headers are an optional part of the request unit sent over a link. This topic describes the FM headers supported by IMS on ISC sessions. The headers addressed in this topic include:

- The ATTACH function management header. This type 5 header is used to attach a process so it can receive session input. It carries the name of the process to be attached synchronously, as well as other parameters to be used by the attached process. All messages have an explicit or implicit ATTACH FM header. The header is implicit when not actually sent with the message. An implicit ATTACH FM header assumes reset parameter values or values of a previous ATTACH as defined later in this topic.
- The error recovery procedure (ERP) function management header. This type 7 header is sent after an error condition requiring an error message to be sent is detected.

- The reset attached process (RAP) function management header. This type 5 header is input to IMS to cause the attached process and the associated data flow control states to be reset.

The following header types are subordinate to the ATTACH FM header and cannot be used unless the ATTACH FM header has previously been sent within that bracket to attach the associated process:

- The SCHEDULER function management header. This type 6 header is sent after the SCHEDULER process has been attached. It carries the name of the process to be asynchronously scheduled within IMS, as well as other parameters required by the SCHEDULER process.
- The SYSMMSG function management headers. The type 6 system message headers precede system messages sent by or received by IMS.
- The data descriptor function management header. This type 4 header is used in conjunction with MFS to send a data structure name, version ID, or a current output field tab separator.
- The QMODEL function management headers. These type 6 headers are used for demand-paged messages sent by IMS Message Format Service.

All function management headers must be on a first-in-chain or only-in-chain. Table 46 summarizes the header types that IMS sends and receives (Y=Supported). These header types are described in the topics that follow.

*Table 46. Function Management Header Types*

Function Management Header Type	Sent by IMS	Received by IMS
FMH4 - Data Descriptor	Y	Y
FMH5		
ATTACH	Y	Y
Reset Attach Process (RAP)		Y
FMH6 - QMODEL		
QGET		Y
QGETN		Y
QPURGE		Y
QSTAT	Y	
QXFR	Y	
FMH6 - SCHEDULER	Y	Y
FMH6 - SYSMMSG		
SYSSTAT (default)		Y
SYSSTAT	Y	Y
SYSERROR	Y	Y
FMH7 - ERP	Y	Y

When receiving a header, IMS ignores any coded parameters beyond the last parameter to which it is sensitive (that is, that IMS supports). The other LU 6.1 subsystem should do the same when receiving headers that IMS sends.

### Using FM Headers to Invoke ISC Edit

In the following situations, IMS can use ISC edit (ISCEDT) to edit transactions, commands, and message switches between LTERMs for an IMS-ISC session:

- The attach manager is in the reset state (between-brackets or following a RAP), and either no ATTACH FM header or an ATTACH FM header that does not specify a destination process name (ATTDPN) is received.
- The destination process name (ATTDPN/SCDDPN) within the ATTACH or SCHEDULER FM header equals ISCEDT or indicates the user-defined alias for ISC edit as defined during system definition on the COMM macro statement.
- The attach manager is not in the reset state, the active process is ISC edit, and either no ATTACH FM header or a header that does not specify an ATTDPN is received.

Input that does not specify the ATTPRN/SCDPRN parameter is edited only for the transaction code and password at the beginning of the message. The optional IMS password and leading characters less than X'41' are deleted during editing. The format and requirements for the IMS transaction code and password are the same as for basic edit. No editing of any kind occurs for the remainder of the message.

Input parameters passed from the attach manager or SCHEDULER (if supplied) are return destination process name (ATTRDPN/SCDRDPN), return primary resource name (ATTRPRN/SCDRPRN), and primary resource name (ATTPRN/SCDPRN).

The input ATTPRN/SCDPRN parameter is passed from the attach manager or SCHEDULER as an IMS transaction code or as the LTERM name on a message switch, as defined under "Initiating a Process: ATTACH FM Header." When the ATTPRN/SCDPRN parameter is supplied, no editing of any kind occurs for the input. ATTPRN/SCDPRN defines an IMS destination, but does not provide an input password to IMS transaction security (if this security is defined for the ISC node).

#### **Related Reading:**

- For examples of using the ATTACH parameter for ISC edit, see Appendix F, "Examples Using ISC Edit ATTACH Parameters," on page 525.
- For information on the format and requirements for the IMS transaction code and password for basic edit, see *IMS Version 9: Administration Guide: System*.

### Initiating a Process: ATTACH FM Header

The ATTACH FM header is used to attach a process to receive session input. It carries the name of the process to be attached synchronously, as well as other parameters used by the attached process. Because ATTACH is defined for synchronous execution, you must understand the relationships between the process to be attached, the IMS message types and execution modes, and the SCHEDULER process.

**Related Reading:** For more information on ISC and IMS execution modes, see "Relationship of ISC and IMS Execution Modes" on page 272.

IMS sends the ATTACH FM header without a SCHEDULER FM header:

- On the conversational, response mode, or IMS command output message replies resulting from an input ATTACH.

- On asynchronous replies that result from a message received on the same session with ATTACH EB.
- When the other half session is bound without SCHEDULER model support.
- On system messages sent by IMS through SYSMSG.

An IMS message can consist of either single or multiple SNA chains as indicated within the ATTACH ATTIU parameter. The ATTACH FM header can be present only once for each input or output IMS message. For output MFS demand-paged messages, the ATTACH FM header is present only on the first output SNA chain. The first input paging request to the demand-paged output must contain an ATTACH (for DPN=QMODEL); subsequent input page requests for the same demand-paged output message can optionally contain an ATTACH (which must also indicate DPN=QMODEL).

**Related Reading:** For information on the format of the ATTACH FM header, see “ATTACH FM Header Format” on page 373.

## Error Recovery Procedure FM Header

IMS sends the FMH7 ERP header and its associated message following a selective receiver ERP exception response (X'0846'). An ERP exception response need not be received by IMS prior to receiving a FMH7 ERP header and associated message. FMH7 messages sent by IMS indicate either RQE1/CD or RQD1/EB, as appropriate. ERP messages sent or received by IMS are limited to a single SNA chain of SCS characters and must not contain VLVB format records. FMH7 messages received by IMS must indicate either CD or EB. RQE1 or RQD1 is allowed on either.

**Related Reading:** For more information on the error recovery procedure (ERP) and its associated ERP message header, see “Selective Receiver ERP” on page 347.

Single-segment error messages created within IMS are 79 characters or less in length. Multisegment messages created within IMS can be greater than 79 characters in length, but each segment has a 79-character maximum length.

Error messages created by input to the ISC error message process for output to the master terminal (or source operator terminal for a message switch) create single- and multisegment output messages (DFS2073 or DFS2083).

IMS inserts error messages into IMS message queues using a default MFS MOD name. These messages are formatted as defined by the MOD during output to a component defined with MFS DPM. These MODs and associated DOFs are contained in the MFS format library.

Each selective receiver ERP message is preceded by an ERP message header that includes the specific system and user error sense codes.

**Related Reading:** For information on the ERP FM header format, see “Error Recovery Procedure (ERP) FM Header” on page 383.

## Resetting the Active Process: RAP FM Header

The reset attached process (RAP) FM header is used to reset the receiving half session's active process and all session states, except bracket and send/receive states, to the equivalent of a between-brackets state.

## Resetting the Active Process: RAP FM Header

IMS receives the RAP FM header, but does not send it. After receiving the RAP request, IMS responds with an ATTACH SCHEDULER, or with LUSTATUS - queue empty if no output is available to be sent. If the RAP request is received during an IMS demand-paged output message, the message is dequeued (committed) before a check for more output is made. The IMS operation performed for the RAP request is the same as for the NEXTMSG operator control request provided with MFS input or the PA2 request from a 3270 device.

The RAP request must be sent without data and must indicate change-direction, RQD2, or RQE2.

**Example:** Figure 57 illustrates the use of the RAP FM header.

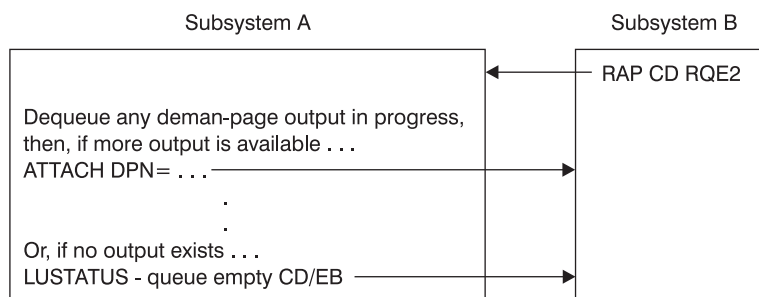

Figure 57. RAP FM Header Example

**Related Reading:** For more information on the RAP FM header, see “Reset Attached Process (RAP) FM Header Format” on page 390.

## Requesting Asynchronous Transaction Processing: SCHEDULER FM Header

ATTACH is defined for synchronous scheduling and execution; SCHEDULER is defined for asynchronous scheduling and execution.

The SCHEDULER process can be attached to send messages to be processed asynchronously. That is, IMS perceives the messages as being processed without regard to scheduling or execution timing, whether output will result at all, and ignoring any synchronous relationship between the input and any resulting reply. Each half session between the logical units might indicate, by using the session bind parameters, whether the SCHEDULER process is supported and available to receive asynchronous messages. The IMS half session always indicates the SCHEDULER process is available. The other half session might indicate that the SCHEDULER process is or is not available to receive asynchronous input.

When the bind indicates that the other half session does not support the SCHEDULER process, IMS defaults to sending each output with the ATTACH FM header.

The SCHEDULER process is attached by indicating the SNA name (X'02') as the ATTACH DPN parameter and by concatenating the SCHEDULER FM header to the ATTACH FM header. During the time that the SCHEDULER is attached, each subsequent message to be scheduled asynchronously must be sent with at least the SCHEDULER FM header, but does not require another ATTACH FM header. Variable-length ATTACH parameters passed to the SCHEDULER are ignored on input and are not sent with output by IMS. The SCHEDULER FM header carries the name of the process to be scheduled (SCDDPN), as well as information

## Requesting Asynchronous Transaction Processing: SCHEDULER FM Header

necessary for scheduling and return-reply routing. SCDDPN is a required parameter for the SCHEDULER and must be supplied on IMS SCHEDULER input. SCDDPN on messages sent by IMS are set from a previous input SCDRDPN or optionally by MFS using the output message format descriptor. When no other value is available, SCDDPN is set to "ISCEDT" as a default.

The SCHEDULER process is always available for IMS input. IMS sends an ATTACH with the ATTDPN parameter set to X'02' (SCHEDULER) concatenated with a SCHEDULER FM header under each of the following conditions:

- When the other half session supports the SCHEDULER model (as defined in the bind parameters).
- When sending an asynchronous reply resulting from input entered previously on the session and scheduled using the SCHEDULER process.
- When sending unsolicited asynchronous messages. Examples of such messages are an IMS message switch or an output reply resulting from an application not scheduled directly as a result of input on the session.

Within IMS, the SCHEDULER supports both single- and multiple-chain input and output messages using the ATTACH ATTIU parameter. IMS does not permit multiple input or output messages to be scheduled using the ATTACH multiple-chain indicator.

The SCHEDULER FM header can be present only once for each input or output IMS message. For output MFS demand-paged messages, the SCHEDULER FM header is present only on the first output SNA chain (first output MFS page). IMS does not send or receive the SCHEDULER SCHEDSTAT, PURGE, or PURGSTAT FM headers.

### Related Reading:

- For information on the input and output requirements for bracket, send/receive, and response protocols for the SCHEDULER, see the data flow control (DFC) protocols defined in "Data Flow Control Protocol Reference" on page 329.
- For more information on the SCHEDULER FM header, see "SCHEDULER FM Header Format" on page 390.

## System Message Process (SYSMSG) and Related FM Headers

The system message process is indicated by a process name in the ATTACH FM header.

Input system messages are routed to the master terminal operator when no ATTPRN is supplied in the ATTACH or SYSERROR FM header for a SYSMSG. This routing is accomplished by converting the incoming SYSMSG into IMS system message DFS2072. If an ATTPRN value is supplied, it becomes the IMS input message destination transaction code or LTERM name. The system message process cannot be used to access the IMS command processor.

A reply can result from an input SYSMSG if the ATTPRN value supplied is for an IMS transaction. This reply is returned through ISC edit or MFS, depending upon the output component definition.

IMS inserts system messages into IMS message queues using a default MFS MOD name. These messages are formatted as defined by the MOD during output to a component defined with MFS DPM. These MODs and associated DOFs are contained in the MFS format library.

## System Message Process (SYSMSG) and Related FM Headers

IMS sends SYSMSG only for:

- IMS broadcast messages
- System messages that IMS sends after sending a response to input. These system messages can occur instead of the application sending a reply (for example, when an abnormal termination occurs). IMS system messages directly solicited by an IMS command are sent as normal replies. Other system-generated messages can result from error conditions. These messages are converted to exception responses to the input transaction and are sent as error messages using the error recovery process (ERP).

MFS might edit an output SYSMSG, depending on the output component definition and whether the reply was inserted with an MFS MOD name.

Messages sent to or received by SYSMSG can include either the SYSSTAT or SYSERROR FM header. The SYSSTAT FM header is assumed by the receiver if no header is supplied by the sender. IMS can receive either header, and attaches a prefix to each header with IMS message number DFS2072 (if the message is to be sent to a master terminal operator). IMS sends broadcast output using the SYSSTAT header. All other IMS system messages sent as SYSMSG use the SYSERROR header. If the ATTACH ATTRDPN or ATTRPRN parameters are supplied on an input message that results in SYSMSG output, these parameters are included in the output SYSERROR FM header to be used by the receiver's SYSMSG process. The ATTACH ATTRDPN and ATTRPRN parameters are not sent for an IMS output SYSMSG.

Single-segment system messages created within IMS are 79 characters or less in length. Multisegment messages created within IMS can be greater than 79 characters in length, but each segment has a 79-character maximum length.

System messages created by input to the ISC SYSMSG process for output to the master terminal create single- and multisegment output messages. System messages created by input to the ISC SYSMSG process in which ATTRPRN and ATTRDPN are specified must have a MID capable of handling multisegment messages with a minimum of five segments.

**Related Reading:** For more information on the system message process, see "SYSMSG Process Headers" on page 391.



---

## Chapter 17. Using MFS with ISC

Message formatting for MFS DPM is specified on the IMS system definition TERMINAL macro statement by the parameter DPM-Xn, where X might be A or B. For ISC nodes, the form DPM-Bn is always used. This chapter addresses the following:

- How MFS DPM-Bn can be invoked to format IMS input and output
- The way in which the ATTACH, SCHEDULER, and reset attached process (RAP) function management headers are used by MFS
- MFS support for the SNA-defined QMODEL and data descriptor function management headers (which control MFS processing)

**Related Reading:** For information on the MFS facilities available to the ISC session using the ATTACH, SCHEDULER, RAP, QMODEL, and data descriptor protocols, see *IMS Version 9: Application Programming: Transaction Manager*.

### **In this Chapter:**

- “Activating MFS Input Formatting”
- “Activating MFS Output Formatting” on page 364
- “MFS Distributed Presentation Management (DPM) Messages” on page 364
- “MFS Page Delete Function” on page 365
- “MFS Online Error Detection” on page 365
- “The ATTACH and SCHEDULER FM Headers under MFS” on page 367
- “Data Descriptor FM Headers” on page 368
- “Controlling Demand-Paged Messages: QMODEL FM Headers” on page 369
- “Request (Input) QMODEL FM Headers” on page 370
- “Reply (Output) QMODEL FM Headers” on page 371
- “The RAP FM Header under MFS” on page 372

Some input MFS format errors (such as invalid cursor, incorrect output formats, or no output formats) are not detectable within IMS before IMS sends the requested response to the input message. In these cases, IMS sends the error message by using ATTACH ATTDPN=SYSMSG. This ATTACH results even if the input message indicated change-direction and exception response and is an implicit acknowledgment to the message.

An ATTACH SYSMSG received by IMS during demand-paged output is treated as an invalid MFS paging request and causes session termination. The received SYSMSG is discarded.

---

## Activating MFS Input Formatting

When MFS is used, input messages can be processed by the message and format descriptors. When IMS receives an input message from an ISC logical unit, basic edit or ISC edit is performed unless MFS is defined for the input component (ATTDSP) and a MID name accompanies the message. The MID name can be supplied by including it either as the ATTDPN parameter on the ATTACH function management header or as the SCDDPN parameter on the SCHEDULER FM header.

## Activating MFS Input Formatting

The MFS escape characters (//) are not supported for ISC. When the MID name is present, MFS edits the message using the specified MID and its associated device input format (DIF).

---

## Activating MFS Output Formatting

MFS output formatting occurs when an output message has an associated message output descriptor (MOD) supplied in one of the following ways:

- The application program supplies a MOD name with the output message.
- The input message is processed by a message input descriptor (MID) whose definition specifies a MOD name for output formatting.
- The output message is a message switch that is created by a MID whose definition specifies a MOD name for output editing.

If no MOD is associated with the output message, no MFS editing occurs. Values for the ATTACH and SCHEDULER parameters are the default values that are defined under these respective header types.

You can use the MOD to specify the next MID name to be used to format input as the result of output. In an ISC session, IMS cannot control the relationship between formatted IMS output messages and subsequent input messages. Therefore, involvement is required by the remote subsystem or user application program to ensure that the proper MID name is used for input MFS formatting. The ATTACH and SCHEDULER RDPN/DPN parameters perform the ISC function of externalizing the next MID on output and invoking MFS formatting on subsequent input.

### Related Reading:

- For information on MFS MID/MOD chaining, see “MFS Application Design” in *IMS Version 9: Application Programming: Transaction Manager*.
- For information on the ATTACH and SCHEDULER RDPN/DPN parameters, see “ATTDPN” on page 378.

---

## MFS Distributed Presentation Management (DPM) Messages

An IMS MFS DPM message can consist of either single or multiple SNA chains as indicated within the ATTACH parameters. For MFS DPM input or output using a device format defined with the paging OPTIONS=MSG, IMS sends or receives the entire message as a single chain of one or more related transmissions. For MFS DPM output using a device format defined with paging OPTIONS=DPAGE or PPAGE, IMS sends each logical or presentation page as a single chain of one or more related transmissions.

MFS output DPM format definitions also allow options for paged output (OPTIONS=PPAGE or DPAGE) to be sent as demand-paged or autopaged. Demand-paged output requires paging requests to the other half session for each output page. Autopaged output is sent as a series of consecutive pages (chains) with no paging requests to the other half session.

MFS DPM input using a device format defined with the paging OPTIONS=DPAGE allows IMS to optionally receive each logical page as a single chain of one or more related transmissions. All chains of autopaged input (multiple logical pages as multiple related input chains) are received consecutively without paging requests by IMS.

FM headers can occur as part of the first or only transmission of each input or output chain of the message.

---

### MFS Page Delete Function

The MFS page delete function is not available for use by an ISC session. `OPTIONS=NPGDEL` is forced on the IMS system definition `TERMINAL` macro statement or an ETO user descriptor, because paging requests other than QMODEL-architected paging requests are not supported. This includes MFS operator control table requests and other forms of input data that might occur during output demand-paging. An error (exception response and appropriate ERP message) occurs if data other than a valid QMODEL paging request is received during demand-paged output. The output message is returned to the queue as a result of the error condition and retransmitted at the next opportunity. If the output demand-paged message is conversational or response mode output, it is immediately resent and input is not allowed until the output message is successfully transmitted or dequeued by a valid QMODEL paging request or appropriate ERP action.

---

### MFS Online Error Detection

The following topics describe how IMS detects input errors, output errors, and paging errors for MFS:

- “Output Errors”
- “Input Errors”
- “Paging Errors” on page 366

### Output Errors

MFS output errors are detected after IMS has already sent the response to any preceding input. If an error is detected during MFS MOD or DOF block selection, an error message is sent as `ATTACH SYSMSG`, and the IMS message is returned to the message queue for retransmission. If the MFS test mode is in effect, it is reset.

Invalid page requests cause error messages to be sent.

### Input Errors

An error message is sent and the input message is rejected if one of the following occurs:

- An error is detected during MFS MID or DIF block selection.
- A nonzero version ID is received in the data descriptor FM header and it does not match the version ID in the MFS descriptor.
- An error is detected during DPAGE selection (that is, no condition is satisfied on matching the DPAGE label with the DSN in the DD FM header or the `COND=` with the data).

If one of the following errors is detected during multiple DPAGE input, an error message is sent to the other subsystem, and the input message is rejected:

- Multiple transmission chains. More data is present in the chain than defined for the DPAGE selected.
- Any mapped-input LPAGE contains no data segments (as a result of segment routines cancelling all segments, for example).

## MFS Online Error Detection

If one of the following errors is detected during a single DPAGE input (that is, multiple DPAGE input is not requested in MFS definitions), an error message is sent and the input message is rejected:

- A single transmission chain is received and contains more data than defined for the DPAGE selected.
- Multiple transmission chains are transmitted.
- The mapped-input message contains no data segments (as a result of segment routines cancelling all segments, for example).

If the input message is cancelled by the User Segment Edit exit routine, or if a User Segment Edit exit routine failure is detected, an error message is sent to the other subsystem. In the latter case, the input message is rejected.

## Paging Errors

An error message is sent to the other subsystem when an invalid paging request (QMODEL FM header) is detected:

- The QNAME parameter on the QGETN or QGET function management header does not match the ATTDQN/SCDDQN parameter on the ATTACH or SCHEDULER FM header sent by IMS. An attached demand-paged output message is returned to the message queue for retransmission. A scheduled demand-paged output message continues to wait for a QGETN with the proper QNAME specified.
- The QORG parameter on the QGETN or QGET FM header is invalid. The output message is returned to the message queue for retransmission.
- The QGETN FM header is received and no output message is in progress.
- A paging request other than QGETN is received as the first input following scheduled demand-paged output (ATTACH SCHEDULER), or a QSTATUS FM header is sent by IMS because of an invalid cursor on a paging request.
- The QGETN FM header is received for an OLP demand-paged output and current cursor position is at the last page.

**Related Reading:** For more information on invalid cursor conditions, see “QSTATUS FM Header” on page 372.

The QGET FM header causes a QSTATUS or an error message to be sent in the following cases:

- Between messages.
- Non-OLP demand-paged output message is in progress. An error message is sent and the output message is placed on the queue for retransmission.
- Cursor value does not contain a valid 2-byte binary number. An error message is sent, and the output message is placed on the message queue for retransmission.
- Cursor value is outside the range for the output message.

### **Related Reading:**

- For more information on invalid cursor conditions, see “QSTATUS FM Header” on page 372.
- For more information on paging errors, see “Error Recovery Procedure FM Header” on page 359.

---

## The ATTACH and SCHEDULER FM Headers under MFS

All input and output messages include an implicit or explicit ATTACH FM header and, optionally, a SCHEDULER FM header. MFS DPM provides format definition options to permit the insertion of input routing parameters (ATTRDPN/SCDRDPN, ATTRPRN/SCDRPRN, and ATTPRN/SCDPRN) into the input data stream. The input ATTDPN/SCDDPN is the MFS MID used to format the input message. MFS DPM provides output format definition options to permit the insertion of user-defined information into these headers.

The ATTACH FM header and SCHEDULER FM header, if required, are sent without data as the only element of the first transmission chain of demand-paged output. The first input paging request to the demand-paged output must contain an ATTACH (for DPN=QMODEL); subsequent input page requests for the same demand-paged output message can optionally contain an ATTACH (and must also indicate DPN=QMODEL). For all other MFS input and output messages the ATTACH (and SCHEDULER, if required) FM headers are sent with data as the first or only element in the first or only transmission chain of the message.

MFS uses the following ATTACH and SCHEDULER FM header parameters:

- ATTDP and ATTIU. These ATTACH parameters indicate whether the message is demand-paged or whether it is single or multiple chain.
- ATTDDBA. This ATTACH parameter indicates the output data blocking algorithm or input data deblocking algorithm to be used by IMS. The data entity deblocked on input becomes the input data record to MFS. MFS then produces a standard IMS message consisting of pages and segments. On output, the MFS record becomes the data entity for output VLVB blocking. An exception is MFS DPM stream mode, which is sent as chain (ATTDDBA) output.
- ATTDPN/SCDDPN and ATTPRN/SCDPRN. The ATTDPN/SCDDPN parameter is used on input to activate MFS input formatting. The ATTPRN/SCDPRN can be inserted into the input data stream and, therefore, made available to the application. On output message replies from IMS, the ATTDPN/SCDDPN or ATTPRN/SCDPRN can be inserted into the ATTACH or SCHEDULER FM headers of the output message processed by MFS as specified by MFS format descriptions. These override the ATTRDPN/SCDRDPN and ATTRPRN/SCDRPRN that might have been wrapped from the source input message ATTACH or SCHEDULER FM headers.
- ATTRDPN/SCDRDPN. The ATTRDPN/SCDRDPN can optionally be inserted into the input data stream and, therefore, made available to the application for input messages processed by MFS DPM. The return destination process name can be inserted into the output ATTACH or SCHEDULER FM header of the output message processed by MFS. The MFS-suggested return destination process to be associated with a reply to the output message is the MID name specified in the NXT= operand of the MOD.
- ATTRPRN/SCDRPRN. The return primary resource name (RPRN) can be inserted into the ATTACH or SCHEDULER FM header of the output message processed by MFS. It can be specified using MFS definition. If returned to IMS with a reply to the message on which it was sent, it determines the destination — transaction or LTERM — that is to receive the input reply.
- ATTDQN/SCDDQN. The destination queue name is sent by IMS on demand-paged output as a message identifier and should be returned on all requests associated with demand-paged messages.

## The ATTACH and SCHEDULER FM Headers under MFS

When the first chain (ATTACH SCHEDULER) of an asynchronous demand-paged output message is successfully sent, the output queue (IMS LTERM) is automatically locked against input or output. This function is also automatic following a QSTATUS FM header sent by IMS because of a cursor error on a demand-paged request. The queue lock state is reset when the page request (ATTACH QMODEL, QGETN with QNAME) is received and the first page of data is sent without resending the ATTACH or SCHEDULER FM header. The queue lock condition is also reset across session failure and subsequent restart. During the time that IMS waits for this page request (QGETN), provided conversation or response mode is not used, IMS can send or receive messages for other LTERMs. During the time that the output LTERM is locked, no input is accepted from the ISC session that produces output to the locked queue because of the input/output component relationships defined for the locked queue using the IMS system definition NAME macro statement or an ETO logon descriptor. Input is accepted that produces output for other LTERMs.

---

## Data Descriptor FM Headers

The input and output data descriptor FM headers are used to receive and send a data structure name and version ID or a field tab separator character.

### Input Data Descriptor FM Header

On input to IMS, this header can follow the ATTACH or SCHEDULER FM header and is used to receive a data structure name (if DPAGE selection is by DPAGE name) and version ID or the input field tab separator character. The input data descriptor FM header should be sent to IMS if input DPAGE selection is to be performed on the DPAGE name; that is, if you specify OPTIONS=DNM on the DIV statement (TYPE=INPUT).

If you set OPTIONS=DNM, and specify no DPAGE name or the wrong DPAGE name, an error occurs.

The version ID should be sent to IMS in the first or only FM header of the input message if MFS is to verify that the correct definition is used to map the data. If the version ID is sent and is X'0000', no verification occurs. The field tab separator is not required on input, because MFS provides for up to eight separators with the FTAB function. If received on input, the field tab separator is used instead of the MFS FTAB specification (if any) for the current transmission.

**Related Reading:** For the format of the input data descriptor FM header, see "Input Data Descriptor FM Header."

### Output Data Descriptor FM Header

On output from IMS, the data descriptor FM header is used to send a data structure name and version ID or the output field tab separator character if OFTAB= parameter of the DIV or the DPAGE statement is specified.

It is sent in the only transmission chain of a nonpaged output message or in each transmission chain of a paged output message. For a nondemand-paged message (OPTIONS=MSG), this header follows the ATTACH or SCHEDULER FM header. For an autopaged message, this header follows the ATTACH or SCHEDULER FM header and precedes the data for the first logical or presentation page. The data descriptor FM header precedes the data for each additional page of output and is the only FM header in the transmission chain. For demand-paged output, this header follows the QFXR header. The version ID is sent only once for each

message in the first or only FM header for the output message. Additionally, if OFTAB is specified and OPTIONS=DNM is requested, the output field tab separator character used for the current transmission is included in the FM header. If OPTIONS=NODNM is specified, a data descriptor FM header is not sent, regardless of whether OFTAB has been defined or not.

**Related Reading:** For the format of the output data descriptor FM header, see “Data Descriptor FM Headers” on page 382.

---

## Controlling Demand-Paged Messages: QMODEL FM Headers

Queue model (QMODEL) headers are sent and received to control demand-paged messages. All demand-paging requests (except RAP) must be made using the QMODEL-defined FM headers.

**Restriction:** MFS DPM-Bn does not support operator control table requests or input messages while sending demand-paged output.

The QMODEL headers that IMS supports are listed in Table 47.

Table 47. IMS-Supported QMODEL Headers

QMODEL Headers	Sent by IMS <sup>1</sup>	Received by IMS <sup>2</sup>
QXFR	X	
QGETN		X
QGET		X
QPURGE		X
QSTATUS	X	

**Notes:**

1. QMODEL headers are not sent between two IMS subsystems.
2. A QMODEL FM header must precede a QMODEL page request for the first page. These FM headers can be preceded by the QMODEL ATTACH FM header with the DPN parameter containing the value X'03'.

QXFR is a QMODEL reply. All other headers are QMODEL requests. Each half session between the logical units might indicate, by using the session bind parameters, whether the QMODEL process is available to receive QMODEL requests. The bind parameters have no effect on QMODEL replies. IMS always indicates “QMODEL available” and is prepared to receive QMODEL (paging) requests to IMS demand-paged output. The other half session might or might not indicate “QMODEL available.” IMS ignores the other half-session bind indication for QMODEL requests, because only QMODEL replies can be sent by IMS.

Queue model uses LU 6.1 protocols to handle messages as follows:

- Although SNA allows multiple messages to be active, IMS messages are serial. That is, only one message is active at any given time. When active message processing is completed, another message can be processed. Synchronous (ATTACH without SCHEDULER) output MFS DPM demand-paged messages are considered active immediately when the first chain (ATTACH) is sent. Demand-paged output sent with ATTACH SCHEDULER does not become active until the first page request is returned to IMS.
- MFS demand-paged output provides for two types of message organization: linear (OPTIONS=DPAGE) and hierarchic (OPTIONS=PPAGE). For both types,

## Controlling Demand-Paged Messages: QMODEL FM Headers

pages can be retrieved sequentially (get next) or linearly (get by cursor). However, linear retrieval is permitted only if operator logical paging (OLP) is defined. Hierarchic retrieval is not supported.

**Related Reading:** For more information on the required bracket, send/receive, and response protocols required for QMODEL FM headers, see “Data Flow Control Protocol Reference” on page 329.

---

### Request (Input) QMODEL FM Headers

The following topics describe the different Request (Input) QMODEL FM Headers:

- “QGETN FM Header”
- “QGET FM Header”
- “QPURGE FM Header” on page 371

#### QGETN FM Header

A QGETN FM header is received by IMS to cause sequential transfer of a single logical or presentation page of MFS DPM demand-paged output. It is the only QMODEL FM header in the chain and is never followed by function management data.

The QGETN FM header is not sent by IMS.

The QGETN FM header can be sent to IMS in the following cases:

- To retrieve first page of demand-paged output. A QGETN must always be the first request following the receipt of a scheduled demand-paged output. It must be preceded by an ATTACH QMODEL FM header.
- Following a QSTATUS FM header that indicates an invalid cursor in scheduled demand-paged output.
- When a non-OLP demand-paged output message is in progress.
- When an OLP demand-paged output message is in progress and the current cursor position is not at the last page of the message.

Each of these cases causes a QXFR FM header to be returned in reply.

The QGETN FM header cannot be sent to IMS in the following cases:

- Between messages. An error message is returned.
- While an OLP demand-paged output message is in progress and the current cursor position is at the last page.

**Related Reading:**

- For more information on invalid cursor conditions, see “QSTATUS FM Header” on page 372.
- For information on the format of the QGETN FM header, see “QGETN FM Header Format” on page 385.

#### QGET FM Header

Use the QGET FM header as input to IMS to transfer to the next, the last, or any logical page, according to cursor.



A QGET FM header is only valid for demand-paged output with operator logical paging defined. It is the only FM header in the input chain and is never followed by function management data.

The QGET FM header is not sent by IMS.

The QGET FM header cannot be sent to IMS in the following cases:

- Between messages. An error message is returned.
- After receiving the ATTACH for a scheduled demand-paged output message. The first paging request for this type of output must be QGETN. QGET can be used after requesting the first output page by QGETN.
- While a non-OLP demand-paged output message is in progress. An error message is returned. The output message is placed on the queue for retransmission.
- When the cursor value does not contain a valid 2-byte binary number. An error message is returned, and the output message is placed on the message queue for retransmission.
- When the cursor value is outside the range for the output message.

### **Related Reading:**

- For information on invalid cursor conditions, see “QSTATUS FM Header” on page 372.
- For information on format of the QGET FM header, see “QGET FM Header Format” on page 384.

## QPURGE FM Header

When IMS receives a QPURGE header, it halts processing on the demand-paged output message in progress. QPURGE can be received by IMS only while an MFS demand-paged output message is active. The QPURGE FM header is the only FM header in the chain and is never followed by function management data. IMS replies to a QPURGE FM header with a QSTATUS. If IMS receives a QPURGE header to delete the demand-paged output message, the message is deleted only after IMS receives a sync-point response in reply to QSTATUS.

The QPURGE FM header is not sent by IMS.

**Related Reading:** For information on the format of the QPURGE FM header, see “QPURGE FM Header Format” on page 386.

---

## Reply (Output) QMODEL FM Headers

The following topics describe the different Reply (Output) QMODEL FM Headers:

- “QXFR FM Header”
- “QSTATUS FM Header” on page 372

## QXFR FM Header

The QXFR header is sent in each output transmission chain for a demand-paged output message in reply to a valid paging request by a QMODEL header. A QXFR FM header can be followed by the data descriptor (DD) FM header (based upon MFS format definitions) and carries logical or presentation page data. This header must not be sent to IMS.

## Reply (Output) QMODEL FM Headers

**Related Reading:** For information on the format of the QXFR FM header, see “QXFR FM Header Format” on page 387.

### QSTATUS FM Header

A QSTATUS FM header is sent by IMS in reply to an input QPURGE FM header or because an invalid cursor was detected on a page request for a demand-paged output.

If a QSTATUS results from a QPURGE during demand-paged output, it is sent to request a sync point. The message is dequeued when the sync-point response is received. The message is returned to the queue and made available for retransmission if an exception sync-point response is received.

A QSTATUS resulting from an invalid cursor during scheduled demand-paged output is sent RQE1/CD and allows a subsequent QGETN to again request the first page of the message or a QPURGE to cause the message to be dequeued.

The QSTATUS FM header is the only FM header in the chain and is not followed by function management data. The QSTATUS FM header must not be sent to IMS.

**Related Reading:** For information on the format of the QSTATUS FM header, see “QSTATUS FM Header Format” on page 387.

---

## The RAP FM Header under MFS

When used by MFS, the reset attached process (RAP) FM header can be sent to IMS to delete the demand-paged output message in progress (prevent further processing). This header is equivalent to the MFS operator control function of NEXTMSG. This header can also be sent to IMS to delete the operator logically paged message in progress. A RAP FM header cannot be followed by function management data. The RAP FM header is not sent by IMS.

**Related Reading:** For information on the format of the RAP FM header, see “Reset Attached Process (RAP) FM Header Format” on page 390.

---

## Chapter 18. FM Header Format Reference

Each header's length is defined by a 1-byte length field. The value in this field includes the length field itself. A concatenation flag indicates whether an additional header follows. Within the header formats, variable- and fixed-length parameters are positional by command code. A 1-byte length field precedes each variable-length positional parameter. The value contained in this length field can be X'00' through X'08' and does not include the length field itself. If the length field contains X'00', the variable parameter is omitted and the next positional variable-length parameter length field occurs followed by its variable-length parameter field. Trailing positional parameter length fields of X'00's at the end of the header can be eliminated for input to IMS and are not sent on output from IMS. IMS also does not send trailing blanks for any of these names.

When receiving a header, IMS ignores any coded parameters beyond the last parameter to which it is sensitive (that is, that IMS supports). The other LU 6.1 subsystem should do the same when receiving headers that IMS sends.

### **In this Chapter:**

- "ATTACH FM Header Format"
- "Data Descriptor FM Headers" on page 382
- "Error Recovery Procedure (ERP) FM Header" on page 383
- "QMODEL FM Headers" on page 383
- "Reset Attached Process (RAP) FM Header Format" on page 390
- "SCHEDULER FM Header Format" on page 390
- "SYSMSG Process Headers" on page 391

---

## ATTACH FM Header Format

The format of the ATTACH FM header is defined in Table 48.

*Table 48. Attach FM Header Format*

Byte	Bits	Name	Content
0		FMHL	
1	0	FMHC	
	1-7	FMHT	B'0000101'
2-3		FMH5CMD	X'0202'

## ATTACH FM Header Format

Table 48. Attach FM Header Format (continued)

Byte	Bits	Name	Content	
4	0-3	FMH5MOD		
			4	Reserved
	5	ATTDP	Session Local Flag	<b>B'0'</b> Not demand-paging
				<b>B'1'</b> Demand-paging
	6-7	ATTIU	Interchange Unit code	<b>B'00'</b> Multiple chain
				<b>B'01'</b> Single chain
				<b>B'10'</b> Reserved
				<b>B'11'</b> Reserved
5		FMH5FXCT	Length of fixed-length parameters must be X'02'	
6		ATTDSP	One-byte hexadecimal input value into a data stream profile. (IMS requires a value from X'00' to X'03' to select components 1-4 respectively. Value X'00', or component 1, is assumed if no ATTACH FM header is received while the Attach manager is in reset state.)	
7		ATTDBA	Application data handling algorithm	
			<b>X'00'</b> Undefined (Input only to IMS. IMS also assumes this as the default value if no ATTACH FM header is received while the attach manager is in reset state.)	
			<b>X'01'</b> Variable length, variable blocked (input/output for IMS)	
			<b>X'02'</b> Document subset of SCS (not supported by IMS)	
			<b>X'03'</b> Card subset of SCS (not supported by IMS)	
			<b>X'04'</b> A chain of RUs (input to/output from IMS)	
			<b>X'05'</b> An RU (input only to IMS)	
			<b>X'06' to X'FF'</b> Reserved	
8-m		ATTDPN <sup>1</sup>	Name of a process to be initiated. For an SNA-defined process, the DPN is a 1-byte, nongraphic hexadecimal character. Supported SNA processes are:	
			<b>X'01'</b> SYSMMSG	
			<b>X'02'</b> SCHEDULER	
			<b>X'03'</b> QMODEL	
			The IMS processes are described under the ATTDPN parameter.	

Table 48. Attach FM Header Format (continued)

Byte	Bits	Name	Content
m+1-n		ATTPRN <sup>1</sup>	Name of primary resource for the process being initiated
n+1-p		ATTRDPN <sup>1</sup>	Name of suggested return process name
p+1-q		ATTRPRN <sup>1</sup>	Name of suggested primary resource for the return process
q+1-r		ATTDQN <sup>1</sup>	Name of queue to be associated with the attached process
r+1-s		ATTACC	Access code—Ignored by IMS.

**Notes:**

1. If the ATTDPN is set to SCHEDULER (X'02'), the remaining ATTACH parameters must not be specified. In this case, an equivalent for each of the asterisked parameters might occur in the concatenated SCHEDULER FM header. These SCHEDULER parameters are prefixed by "SCD" rather than by "ATT", but follow the same definition and rules as those for ATTACH.

**Related Reading:** For examples of using the ATTACH parameters, see Appendix H, "ISC Data Flow Control Examples," on page 579 and Appendix F, "Examples Using ISC Edit ATTACH Parameters," on page 525.

The following topics provide additional information about the parameters in the ATTACH FM header that are supported by IMS:

- "ATTIU"
- "ATTDSP" on page 376
- "ATTDDBA" on page 377
- "ATTDPN" on page 378
- "ATTPRN" on page 379
- "ATTRDPN and ATTRPRN" on page 380
- "ATTDQN and ATTDQ" on page 381
- "ATTACC" on page 381

## ATTIU

The interchange unit code (ATTIU) indicates whether a single input or output IMS message consists of one or more SNA chain. All input messages that are not MFS-autopaged messages might indicate either single or multiple chain, but are restricted to one actual transmission chain indicating end-of-message. MFS-autopaged input messages might indicate multiple chain regardless of whether the message is actually one or more than one SNA chain. MFS also offers an option that permits single chain messages to produce multiple DPAGES. Non-MFS and MFS output that is not autopaged is always sent as a single transmission chain with ATTIU indicating single chain. MFS-autopaged output messages are always sent with ATTIU indicating multiple chain.

**Restriction:** IMS does not support any relationship between consecutive input or output messages. Therefore, the interchange unit code indicating multiple chain cannot be used to send IMS batched input messages or consecutive messages to be scheduled using the SCHEDULER process.

IMS requires attached (synchronous) input message switches to be one chain with at least EB specified.

## ATTACH FM Header Format

**Restriction:** IMS does not support MFS-autopaged synchronous input message switches of more than one SNA chain.

The ATTIU parameter is not automatically retained from one input or output message to another. This parameter must be explicitly provided with each input message, or by MFS if the output message is multichain and is formatted by MFS. The input reset state for ATTIU is “multiple chain.”

## ATTDSP

The data stream profile (ATTDSP) parameter is ignored when attaching QMODEL (ATTDPN=X'03'). During other input, the ATTDSP field indicates a specific IMS input component. The input component is used to identify an input IMS LTERM from a set of LTERMs (LTERM subpool) allocated to the session. The input DSP value must indicate a valid input component (an IMS LTERM defined with the input component value), or the input is rejected.

Several internal IMS functions are associated with the LTERM defined for the input component. For example, the LTERM defines a particular origin (input) and destination (output) path within IMS. This output destination can be the same as, or different from, the input origin LTERM and represents a stable application and operator reference point within IMS.

For statically defined terminals, input terminal security can be defined for the input LTERM. This security authorization can be unique for each LTERM or can represent a security level, or group, within IMS. Input terminal security authorizes access to IMS terminals, transactions, and commands.

The input ATTACH DSP parameter remains in effect until it is:

- Changed by another ATTACH
- Reset by a system failure
- Backed out to its value at the last sync point by the ERP
- Reset at between-brackets state
- Reset by the RAP FM header

The input reset state for the ATTDSP parameter is X'00' or “component 1.”

Because IMS does not remember the active input ATTDSP across IMS system failures, the ATTDSP must be provided using an ATTACH FM header to restore the receiving process after a bind or negotiable bind response indicating “in-brackets” (possible restart).

**Related Reading:** For more information on the restart process, see “Coordinating the Restart Process” on page 309.

The output LTERM is determined by either the LTERM selected for input or by the message sender, as for message switches and broadcast messages. IMS also allows the receiving message processing program (MPP) to change the destination of resulting output by issuing a CHNG call and inserting the output to a modifiable alternate PCB. For all system messages resulting directly from input (for example, commands), the output LTERM selected is the normal destination LTERM defined for the LTERM from which the input originated.

During output, the DSP field is set to the output component value associated with the output LTERM.

IMS Message Format Service can be defined as available on a component-by-component basis. The output component also specifies the bracket and send/receive protocol to be used for asynchronous output sent using the ATTACH having a DPN parameter indicating "SCHEDULER."

## ATTDBA

The deblocking algorithm (ATTDBA) determines the data blocking and deblocking algorithm to be used. This algorithm, along with an indication of whether MFS is being used, determines the amount of data presented to or from a process for a single get or put operation.

When IMS is sending messages and MFS is not being used, each segment of the message on the message queue becomes a data entity within the RU (or chain of RUs). If a segment of the message spans message queue records (LRECLs), then each spanned portion of the segment becomes a data entity. If MFS is used, the segments are blocked and sent as a data entity according to the definition of the MFS record.

When IMS receives messages, each data entity of the input message is inserted in the message queue as a segment of the message. Because ISC does not support spanned queue segments on input, the largest message queue LRECL must be large enough to handle the largest data entity or MFS data record received. If this LRECL definition is exceeded, an error is detected and an appropriate error message is produced (DFS074). Also, the actual space available in the message queue is reduced by any variable prefix items on the message.

**Related Reading:** For more information on prefix segments, see *IMS Version 9: Installation Volume 1: Installation Verification*.

IMS implements four of the algorithms defined by SNA:

### UNDEFINED

Same as RU, below, for IMS.

**RU** Input RU is the entity presented to the attached process. IMS receives this DBA value but does not send it.

### VARIABLE LENGTH, VARIABLE BLOCKED (VLVB)

Each data entity sent or received is preceded by a 2-byte length field that allows it independence from RU size or boundaries. Several data entities can be blocked into a single RU, or a data entity can span RUs. The length includes the 2 bytes for the length field itself.

### CHAIN OF RUs

Each data entity is sent or received as a single SNA chain.

Each message received by IMS is deblocked based on the ATTDBA field in the ATTACH FM header. The input ATTDBA field value must indicate a supported algorithm, or the input is rejected.

The input ATTACH DBA parameter remains in effect until it is:

- Changed by another ATTACH
- Backed out to its value at the last sync point by the ERP
- Reset at between-brackets state
- Reset by the RAP FM header
- Reset by a session failure

## ATTACH FM Header Format

The input reset state for the ATTDDBA parameter is “UNDEFINED” (equivalent to “RU”).

Because IMS does not remember the active input ATTDDBA across IMS system failures, the ATTDDBA must be provided using an ATTACH FM header to restore the receiving process after a bind or negotiable bind response indicating “in-brackets” (possible restart).

**Related Reading:** For more information on the restart process, see “Coordinating the Restart Process” on page 309.

With the exception of output using MFS stream mode, output from IMS is automatically sent indicating the variable-length, variable blocked (VLVB) algorithm in the ATTACH or SCHEDULER FM header. This output is sent indicating chain assembly.

## ATTDPN

The destination process name (ATTDPN) parameter identifies, explicitly or implicitly, the input process to be attached to the half session. One responsibility of the attached process is to determine, for the receiving subsystem, the destination of the input message within that subsystem. In some cases, the named process might be the message destination. Within IMS, the receiving process (except basic edit) uses the input primary resource name (ATTPRN), if provided, as the message destination transaction queue or LTERM. If an ATTPRN is not provided, the standard IMS algorithm for determining message destination is used.

### **Related Reading:**

- For more information on the ATTPRN parameter, see “ATTPRN” on page 379.
- For more information on the IMS algorithm for determining message destination, see *IMS Version 9: Administration Guide: System* under “IMS Messages and Their Scheduling.”

All attached processes execute synchronously with the session. However, some processes can schedule additional work to be done asynchronously within IMS. The process attached remains attached until it is:

- Changed by another ATTACH
- Backed out to its value at the last sync point by the ERP
- Reset by the end-bracket indicator
- Reset by the RAP FM header
- Reset by a system failure

The input reset state for the ATTDPN parameter is “ISCEDT”.

Because IMS does not remember the active input ATTDPN across IMS system failures, the ATTDPN must be provided using an ATTACH FM header to restore the receiving process after a bind or negotiable bind response indicating “in-brackets” (possible restart).

The ATTDPN parameter might indicate that the process to be attached is one of the following:

- ISC edit (‘ISCEDT’ or user-named alias)
- IMS Basic Edit (‘BASICEDT’)
- MFS formatting (MFS MID name)



- System Message (SYSMSG), X'01'
- SCHEDULER model, X'02'
- Queue model (QMODEL), X'03'

With the exception of MFS and QMODEL, these processes are always available. MFS is only available if defined for the input component (ATTDSP) during IMS system definition. If the ATTDPN is an MFS MID name and MFS is not available, the input message is rejected. QMODEL is available only following an MFS demand-paged output message.

ISCEDT (as well as the alias defined by the user for ISCEDT during IMS system definition) and BASICEDT are reserved names, and cannot be used as MFS MID or MOD names. Use of these names results in the use of the named process rather than an MFS process.

ISC edit is selected if no ATTACH FM header (or no ATTDPN) is supplied when the Attach manager is in reset state. The “active” process is used if no ATTACH FM header (or no ATTDPN) is supplied when the attach manager is not in the reset state.

IMS sets the output ATTDPN on a return reply to the value contained in the ATTRDPN parameter optionally provided within the ATTACH of the previous input request. When sending system messages, IMS automatically inserts the SYSMSG ATTDPN where necessary. MFS DPM provides a way to optionally specify, override, or delete the output ATTDPN by using the output message format descriptor. When the ATTDPN parameter is not available for output, a 1-byte field containing X'00' is included within the output ATTACH FM header.

**Related Reading:** For information on the ATTRDPN and ATTRPRN parameters, see “ATTRDPN and ATTRPRN” on page 380.

## ATTRPN

The ATTACH primary resource name (ATTRPN) parameter represents the destination for an input message in the receiving subsystem. This parameter is sent on a return reply from a remotely executed message that results from the returning reply message of the ATTACH ATTRPRN parameter that was sent on a message request. However, in situations where the message request contains no input ATTRPRN, the output ATTRPN parameter can be created using MFS, based on user-defined information.

IMS does not permit specification of IMS command verbs as PRNs.

This destination normally represents a terminal (an LTERM), rather than an application program. If the request ATTRPRN/reply ATTRPN represents an application program, consider the synchronous versus asynchronous relationship between the source application program and the remote transaction executions.

Further, you should consider input transaction security requirements for processing and routing the reply. If supplied on input to IMS, the ATTRPN is used as an IMS transaction code or as the LTERM name for a message switch. The data stream is not edited for destination and security information. If the ATTRPN represents a transaction, and if password security (which applies to statically defined terminals only) was defined for the node, an input security error results, because no available source exists for the input password.

## ATTACH FM Header Format

**Related Reading:** For more information on password security, see *IMS Version 9: Installation Volume 1: Installation Verification*.

The ATTPRN is rejected during IMS conversation mode when an application has previously inserted the transaction code into the SPA. The ATTPRN only applies to a single message instance and overrides, but does not destroy, any “preset” destination established using an IMS /SET command. Subsequent messages with no ATTACH FM header or with an ATTACH FM header where the ATTPRN parameter is not supplied, can use any preset destination previously established by the IMS /SET command or by an IMS transaction code, LTERM name, or command verb supplied in the data or through MFS formatting.

IMS sets the output ATTPRN on a return reply to the value contained in the ATTRPRN parameter optionally provided within the ATTACH of the previous input request.

**Related Reading:** For more information on ATTRDPN and ATTRPRN, see “ATTRDPN and ATTRPRN.”

MFS DPM provides a means to optionally specify, override, or delete the output ATTPRN using an output message format descriptor. When this parameter is not present, a 1-byte field containing X'00' is sent with the output ATTACH FM header.

The ATTPRN is not automatically retained from one input or output message to another. This parameter must be explicitly provided with each input message, or through the output MFS descriptors if the output message is processed by MFS.

## ATTRDPN and ATTRPRN

The return destination process name (ATTRDPN) and return primary resource name (ATTRPRN) parameters define the reply process and the return primary resource within the source session and should be returned to the source session on resulting replies to facilitate return-reply routing within the source session.

If provided on input to IMS and not changed or deleted by an output MFS format description, these parameters are returned to the source session unmodified in the reply ATTACH FM header as the output ATTRDPN and ATTRPRN parameters respectively. These parameters are associated with the message to be processed and are recovered with the message across session and subsystem failures.

The input ATTRDPN and ATTRPRN are not automatically retained from one input or output message to another. The ATTRDPN and ATTRPRN must be explicitly provided with each input message or through the MFS output format descriptors when MFS DPM is used for output. The ATTRDPN results from MFS if a next MID was specified in the MOD.

A different procedure is followed when the reply is to be returned on a session different from the session on which the input message originated. If the output ATTRPRN is not set by MFS, and the source of the output message is not associated with the same session, IMS does not wrap the input ATTRDPN and ATTRPRN as the output ATTRDPN and ATTRPRN respectively. In this case, IMS also automatically inserts the source LTERM name of the terminal entering the input message switch or transaction (for alternate PCB output) as the output ATTRPRN parameter.

When the ATTRDPN parameter is not available for output, a 1-byte length field containing X'00' is included in the output ATTACH FM header.

Table 49 and Table 50 summarize IMS actions relative to the DPN, PRN, RDPN, and RPRN fields in the ATTACH and SCHEDULER headers sent with the message.

*Table 49. IMS Interpretations for the DPN, PRN, RDPN, and RPRN Fields*

<b>Input FMH</b>	<b>IMS Interpretation</b>
DPN	MFS MID name or input message editor name (ISC edit or basic edit). Defaults to ISCEDT if not supplied.
PRN	Input transaction code or LTERM name, overriding data stream and preset mode except during conversation.
RDPN	Saved as default reply DPN field.
RPRN	Saved as default reply PRN field.

*Table 50. IMS Actions for the DPN, PRN, RDPN, and RPRN Fields*

<b>Output FMH Field</b>	<b>IMS ACTION Reply Message Sent on Same Session as Input</b>	<b>IMS ACTION Reply Message or Asynchronous Output Sent on another Session</b>
ATTDPN	Wrapped input ATTRDPN if provided; optionally overridden by MFS <sup>1</sup>	Provided only using MFS <sup>1</sup>
ATTPRN	Wrapped input ATTRPRN; optionally overridden by MFS	Provided only using MFS
ATTRDPN	Provided only using MFS	Provided only using MFS
ATTRPRN	Provided only using MFS	Automatically defaulted to source LTERM name; optionally overridden by MFS

**Notes:**

1. For ATTACH-only output, if no parameter is available, the DPN is not sent. For SCHEDULER output, the default is ISCEDT.

## **ATTDQN and ATTDQ**

The destination queue name (ATTDQN) parameter names a specific message instance. This parameter is valid only for output MFS demand-paged messages. For MFS demand-paged output, ATTDQN is sent by IMS as an output message identifier. This name can then be used by the other half session as the QNAME parameter within paging requests to access the IMS demand-paged output message. Within IMS, only one message can be active for a given session at any one time. This means that after output paging begins on a message and until the paging operation is terminated, all input must be paging requests indicating the same QNAME (from ATTDQN) value. The session-local flag (ATTDP) in the ATTACH FM header is set to 1. ATTDQN and ATTDP are not sent or received under other conditions.

## **ATTACC**

IMS does not send the access code (ATTACC) parameter during output, and ignores this parameter on input.

## Data Descriptor FM Headers

Table 51 and Table 52 show the formats of the input and output data descriptor FM headers.

*Table 51. Input Data Descriptor FM Header Format*

Byte	Bits	Name	Contents
0	0-7	FMHL	Length
1	0	FMHC	
	1-7	FMHT	B'0000100'
2	0-7	FMH4FXCT	Fixed-length parm (X'03')
3	0-7	FMH4DTYP	
		FMH4UNDF	X'00' Reserved
		FMH4FIX	X'40' Field formatted record (FFR) - Fixed
		FMH4FXSP	X'41' FFR - All fields terminated by Separator (Note 1)
		FMH4MXSP	X'42' FFR - Fields terminated by Separator or Length defined by map X'43' -X'FF' Reserved (Note 1)
4		FMH4SEP	Separator character (Note 2)
5	0-7	FMH4PCTL	Presentation control byte (Note 3)
6-m		FMH4DSN	Data structure name (Note 4)
m+1-n		FMH4BDT	Block data type (Note 3)
n+1-p		FMH4VERS	Version ID (Note 5)

**Notes:**

1. From DIV or DPAGE statement.
2. Not required, because it is received on MFS format description.
3. Ignored by IMS if sent.
4. DPAGE name if DPAGE selection is to be performed on the data structure name. FMT name if OPTIONS=MSG. Required field.
5. Version ID to be used by MFS to verify that the correct definition is used to map the data. This field should be present only once for each input message if multiple transmission chains are used to create the input message. If present once for each message, it should be sent in the first transmission chain of the message. If the version ID is not sent or it is X'0000', MFS descriptor verification is not performed.

*Table 52. Output Data Descriptor FM Header Format*

Byte	Bits	Name	Contents
0	0-7	FMHL	Length
1	0	FMHC	
	1-7	FMHT	B'0000100'
2	0-7	FMH4FXCT	Fixed-length parm (X'03')

Table 52. Output Data Descriptor FM Header Format (continued)

Byte	Bits	Name	Contents
3	0-7	FMH4DTYP	
		FMH4UNDF	X'00' Reserved
		FMH4FIX	X'40' Field formatted record (FFR) - Fixed
		FMH4FXSP	X'41' FFR - All fields terminated by separator
		FMH4MXSP	X'42' FFR - Fields terminated by separator or length defined by map X'43' - X'FF' Reserved
4		FMH4SEP	Separator character
5	0-7	FMH4PCTL	Presentation control byte (Note 1)
6-m		FMH4DSN	Data structure name (Note 2)
m+1-n		FMH4BDT	Block data type (Note 3)
n+1-p		FMH4VERS	Version ID (Note 4)

**Notes:**

- Set to 0 on output.
- FMH4DSN is:
  - The FMT name if OPTIONS=MSG
  - The DPAGE name if OPTIONS=DPAGE
  - The PPAGE name if OPTIONS=PPAGE
- Omitted if version ID not present. Set to 0 if version ID present.
- Version ID specified in FMT definition or calculated by MFS if the default is used. This field is present only in the first or only data descriptor FM header for the message.

## Error Recovery Procedure (ERP) FM Header

Table 53 shows the format of the ERP FM header.

Table 53. Error Recovery Procedure (ERP) FM Header

Byte	Bits	Name	Contents
0		FMHL	Length
1	0	FMHC	
	1-7	FMHTYPE	X'07'
2-5		ERPSENSE	SNA sense code that would appear on error response
6-7		ERPSEQ	Sequence number of chain for which error was detected

## QMODEL FM Headers

The beginning of each header is fixed-length. This fixed-length area is followed by a variable number of fixed-length subfields, followed by a variable number of variable-length subfields.

## QGET FM Header Format

Table 54 shows the format of the QGET FM header.

Table 54. QGET FM Header Format

Byte	Bits	Name	Contents	
0		FMHL	Length	
1	0	FMHC		
	1-7	FMHT	Type: B'0000110'	
2-3		FMH6CMD	Command Code: X'0A10'	
4		FMH6MOD	Modifier	
	0	FMH6LNSZ	B'0' 1-Byte Length Fields	
	1-6		Reserved	
	7	QGETLAST	B'1' Coded request, get last <sup>1</sup>	
5		FMH6FXCT	Length of Fixed-Length Parameters (=X'01')	
6		QORG	Type of paging request	
			X'00'	Queue organization not specified. Valid on input to IMS.
			X'01'	Sequential. Invalid.
			X'02'	Linear. Valid on input to IMS if it matches the QORG in the QXFER sent by IMS. <sup>2</sup>
			X'03'	Hierarchic. Not supported by IMS.
			X'04' to X'FF'	Reserved
7-m		QNAME	Q from which records are retrieved. IMS message ID (ATTDQN/SCDDQN) <sup>3</sup>	
m+1-n		QCURSOR	Cursor vector in target queue <sup>4</sup>	
n+1-p		QTRNSZ	Size of maximum record to be returned (binary). Ignored by IMS if sent. All fixed-length parameters must be present when you use this header.	

Table 54. QGET FM Header Format (continued)

Byte	Bits	Name	Contents
<b>Notes:</b>			
1.			The QGETLAST selects a logical page whose value is equal to the last logical page in the message. The QGET FM header is valid and causes a QXFR reply only if the OLP demand-paged output message is in progress and the cursor value requested is within the range of the output message.
2.			If QORG is invalid, an error message is sent and the output message is returned to the message queue for retransmission.
3.			The QNAME (message identifier) is required on each page for scheduled demand-paged output and is optional for synchronous demand-paged output. If the QNAME parameter is present, it must match the ATTDQN/SCDDQN parameter in the ATTACH FM header sent by IMS. If QNAME is not specified for synchronous demand-paged output, IMS assumes it to be the same as the ATTDQN parameter name. If the QNAME parameter does not match the ATTDQN/SCDDQN parameter, an error message is sent and the output message is returned to the message queue for retransmission.
4.			The cursor vector consists of one 2-byte binary number representing the logical page number. IMS does not support hierarchic retrieval; therefore, the 2-level cursor (logical page number followed by the presentation page number) is invalid and results in an error message being issued. The length value of the QCURSOR is 2. The next 2 bytes contain the logical page number (absolute) request.

## QGETN FM Header Format

Table 55 shows the format of the QGETN FM header.

Table 55. QGETN FM Header Format

Byte	Bits	Name	Contents
0		FMHL	Length
1	0	FMHC	
	1-7	FMHT	Type: B'0000110'
2-3		FMH6CMD	Command Code: X'0A10'
4		FMH6MOD	Modifier
	0	FMH6LNSZ	B'0' 1-Byte Length Fields
	1-7		Reserved
5		FMH6FXCT	Length of Fixed-Length Parameters (=X'01')
6		QORG	Type of paging request
			X'00' Queue organization not specified. This form is valid for both OLP and non-OLP output.
			X'01' Sequential. <sup>1</sup>
			X'02' near. <sup>1</sup>
			X'03' Hierarchic. Not supported by IMS.
	X'04' to X'FF' Reserved.		
7-m1		QNAME	Q from which pages are retrieved. Specifies a message ID (ATTDQN/SCDDQN) <sup>2</sup>

*Table 55. QGETN FM Header Format (continued)*

Byte	Bits	Name	Contents
m+1-n		QTRNSZ	Size of maximum record to be returned (binary). Ignored by IMS if sent.

**Notes:**

1. If QORG is specified, the QORG specified on the resulting QXFR FM header sent by IMS must match it. Otherwise, an error message is sent and the output message is returned to the message queue for retransmission.
2. The QNAME (message identifier) is required on each page request for scheduled demand-paged output and is optional for synchronous demand-paged output. If the QNAME parameter is present, it must match the ATTDQN/SCDDQN parameter in the ATTACH FM header sent by IMS. If QNAME is not specified for synchronous demand-paged output, IMS assumes it to be the same as the ATTDQN parameter name. If the QNAME parameter does not match the ATTDQN/SCDDQN parameter, an error message is sent and the output message is returned to the message queue for retransmission.

## QPURGE FM Header Format

Table 56 shows the format of the QPURGE FM header.

*Table 56. QPURGE FM Header Format*

Byte	Bits	Name	Contents
0		FMHL	Length
1	0	FMHC	
	1-7	FMHT	Type: B'0000110'
2-3		FMH6CMD	Command Code: X'0A06'
4		FMH6MOD	Modifier
	0	FMH6LNSZ	B'0' 1-Byte Length Fields
	1-7		Reserved
5		FMH6FXCT	Length of fixed-length parameters (=X'01')
6		QORG	Type of queue purge function (if multiple DPAGE input) or paging request (if demand-paged output) <sup>1</sup>
7-m		QNAME	Name of IMS message ID (ATTDQN/SCDDQN) <sup>2</sup>

**Notes:**

1. If IMS receives QPURGE during demand-paged output, the QORG, if specified (that is, QORG is not equal to 0), must match the QORG specified in the QXFR FM header sent by IMS.
2. The QNAME (message identifier) is required on each page request for scheduled demand-paged output and is optional for synchronous demand-paged output. If IMS receives QPURGE during demand-paged output, the QNAME, if specified, must match the ATTDQN/SCDDQN parameter (message ID) in the ATTACH FM header sent by IMS. If QNAME is not specified for synchronous demand-paged output, IMS assumes the same name as the ATTDQN parameter name. If the QNAME parameter does not match the ATTDQN/SCDDQN parameter, an error message is sent and the output message is returned to the message queue for retransmission.



## QSTATUS FM Header Format

Table 57 shows the format of the QSTATUS FM header.

Table 57. QSTATUS FM Header Format

Byte	Bits	Name	Contents
0		FMHL	Length
1	0	FMHC	
	1-7	FMHT	Type: B'0000110'
2-3		FMH6CMD	Command code: X'0A0A'
4		FMH6MOD	Modifier
	0	FMH6LNSZ	B'0' 1-Byte length fields
	1-7		Reserved
5		FMH6XCT	Length of fixed-length parameters (=X'02')
6		QORG	Type of queue add/retrieval requests. <sup>1</sup>
7	0-4		Not supported by IMS. Bit values should be B'0'.
	5	QINVCUR	B'0' if message is a reply to QPURGE. B'1' Invalid Cursor Indicates invalid logical page request received for OLP output.
	6-7		Not supported by IMS.
8			Reserved
9-12		QCURSOR	Current cursor value is 0 <sup>2</sup>
13-16		QSENSE	Sense data <sup>3</sup>
17-n		QNAME	Message ID (ATTDQN/SCDDQN)

### Notes:

1. If QSTATUS is sent by IMS in reply to the QPURGE, QORG is not specified (that is, QORG contains the value of zero). If QSTATUS is sent by IMS in reply to QGET by cursor request, QORG is set to linear (that is, QORG contains the value of two).
2. This parameter is present only if the QINVCUR value is set to B'1'. The cursor value is set to 0. A QGETN request retrieves the first page of the message for which this error (invalid cursor) was detected.
3. This parameter is present only if the QINVCUR value is set to B'1'. It consists of the DFS223 error message as a binary number.

## QXFR FM Header Format

Table 58 shows the format of the QXFR FM header.

Table 58. QXFR FM Header Format

Byte	Bits	Name	Contents
0		FMHL	Length
1	0	FMHC	
	1-7	FMHT	Type: B'0000110'
2-3		FMH6CMD	Command Code: X'0A08'

## QMODEL FM Headers

Table 58. QXFR FM Header Format (continued)

Byte	Bits	Name	Contents
4		FMH6MOD	Modifier
	0	FMH6LNSZ	B'0' 1-Byte Length Fields
	1-7		Reserved
5		FMH6FXCT	Length of fixed-length fields (=X'02')
6		QORG	Types of paging requests valid for this message.
		X'01'	Sequential retrieval of pages. Operator logical paging (OLP) is not defined. Message is dequeued after successful transmission of last page.
		X'02'	Linear retrieval of pages. Operator logical paging (OLP) or browsing is allowed. Message is dequeued only by explicit action from the other subsystem (RAP or QPURGE FM header is received).
		X'03'	Hierarchic retrieval of pages. Not supported by IMS.
		X'00', X'04'-X'FF'	Reserved.
7	0-4	Reserved	
	5	QDISP	B'0'Disposition is save.
	6		Reserved.
	7	QEMSG	B'0'Not end of message B'1'End of message Set to B'1' if last logical page (OPTIONS=DPAGE) or last presentation page (OPTIONS=PPAGE) of a message is transmitted.
8-n		QCURSOR <sup>1</sup>	Cursor vector for current message. For OPTIONS=PPAGE, this field includes a 1-byte length field of value 4 followed by the 2-byte current logical page number and the 2-byte current presentation page number. For OPTIONS=DPAGE, this field includes a length field of value 2, followed by the current logical page number. <sup>2</sup>
n+1-n		QCOUNT <sup>1</sup>	Number of occurrences of pages at lowest level of cursor. If present, this field includes a length byte of value 2, followed by the defined number of pages in the current logical page. The QCOUNT field is present only if the defined number of presentation pages in the current logical page is greater than 1.

Table 58. QXFR FM Header Format (continued)

Byte	Bits	Name	Contents
n+1-p		QRECLNG	Length of record before truncation. If 0, then either record was not truncated or QTRNSZ on QGET(N) was ignored. This field is not supported by IMS and will not be included in the FM header.

**Notes:**

1. If operator logical paging (OLP) is allowed, the QCURSOR and QCOUNT fields contain information the receiver can use for formulating subsequent QGET by cursor requests.
2. Assume the following output message with OPTIONS=PPAGE:
 

Logical Page 1	3 Presentation Pages Defined
Logical Page 2	1 Presentation Page Defined
Logical Page 3	2 Presentation Pages Defined

Table 59 illustrates the values placed in the QCURSOR and QCOUNT fields with sequential retrieval requests.

Table 59. QCURSOR and QCOUNT Values with Sequential Retrieval Requests

Transmission	Count/LP	No./PP No.	Qcursor Count/PP No.	Qcount Comment
1	4 / 1	1	2 / 3	Logical Page 1
2	4 / 1	2	2 / 3	Logical Page 1
3	4 / 1	3	2 / 3	Logical Page 1
4	4 / 2	1	(omitted)	Logical Page 2
5	4 / 3	1	2 / 2	Logical Page 3
6	4 / 3	2	2 / 2	Logical Page 3

**Note:**

Output Message with OPTIONS=DPAGE:

- Logical Page 1
- Logical Page 2
- Logical Page 3

Table 60 illustrates the values placed in the QCURSOR field with sequential retrieval requests.

Table 60. QCURSOR Values with Sequential Retrieval Requests

Transmission	Qcursor Count/LP	Qcount	Comment
1	2 / 1	Not Present	Logical Page 1
2	2 / 2	Not Present	Logical Page 2
3	2 / 3	Not Present	Logical Page 3

## Reset Attached Process (RAP) FM Header Format

Table 61 shows the format of the Reset Attach Process (RAP) FM header.

Table 61. Reset Attached Process (RAP) FM Header Format

Byte	Bits	Name	Contents
0		FMHL	
1	0	FMHC	
	1-7	FMHT	B'0000101'
2-3		FMH5CMD	X'0204'
4		FMH5MOD	
	0	FMH5LNSZ	B'0': 1-byte parameter length field
	1-7		Length of parameter length fields B'0': 1-byte parameter length field B'1': Reserved
5		FMH5FXCT	Length of fixed-length parameters (X'00')

## SCHEDULER FM Header Format

Table 62 shows the format of the SCHEDULER FM header.

Table 62. SCHEDULER FM Header Format

Byte	Bits	Name	Contents	
0		FMHL		
1	0	FMHC		
	1-7	FMHT	B'0000110'	
2-3		FMH6CMD	X'0802'	
4		FMH6MOD		
	0	FMH6LNSZ	B'0': 1-byte parameter length field	
	1		FMH6RPLY	<b>B'0'</b> No reply <b>B'1'</b> Reply <sup>1</sup>
		2	FMH6PROT	B'0' No protection; <sup>2</sup> B'1' Protection
	3		FMH6DELY	<b>B'0'</b> Timer optional <b>B'1'</b> Timer required <sup>1</sup>
		4-7		Reserved
	5		FMH6FXCT	Length of fixed-length parameters - X'01'
6			Schedule Request control	
	0	SCDTIME	Initiation delay specification <b>B'0'</b> Interval <b>B'1'</b> Time Not supported by IMS	
		1-7		Reserved
7-m		SCDDPN <sup>3</sup>	Name of process to be initiated. (Required field)	

Table 62. SCHEDULER FM Header Format (continued)

Byte	Bits	Name	Contents
m+1-n		SCDPRN <sup>3</sup>	Name of the primary resource for the process to be initiated
n+1-p		SCDRDPN <sup>3</sup>	Suggested name of the return process
p+1-q		SCDRPRN <sup>3</sup>	Suggested name of the primary resource for return process name
q+1-r		SCDDQN <sup>3</sup>	Name of queue associated with process
r+1-s		SCDREQN	Name of this process request instance (Not supported by IMS)
s+1-t		SCDDELY	Time interval to be decremented prior to initiation of destination process. (Not supported by IMS)

**Notes:**

1. Must be 0 on both input and output.
2. On input, this field is ignored. On output, this field is set to 0 for nonrecoverable output and to 1 for recoverable output.
3. See “ATTDPN” on page 378, “ATTPRN” on page 379, “ATTRDPN and ATTRPRN” on page 380, “ATTRDPN and ATTRPRN” on page 380, and “ATTDQN and ATTDQ” on page 381 for a more detailed description of these parameters. In the ATTACH topic, these parameters are prefixed by “ATT” rather than “SCD”. The rules for operation of these SCHEDULER parameters are the same as the rules defined for the ATTACH parameters.

## SYMSMSG Process Headers

Table 63 and Table 64 on page 392 show the formats of the SYMSMSG process headers.

## SYSEERROR FM Header Format

Table 63 shows the format of the SYSEERROR FM header.

Table 63. SYSEERROR FM Header Format

Byte	Bits	Name	Contents
0		FMHL	
1	0	FMHC	
	1-7	FMHT	B'0000110'
2-3		FMH6CMD	X'0404'
4		FMH6MOD	
	0	FMH6LNSZ	B'0': 1-byte parameter length field
	1-7		Reserved
5		FMH6FXCT	Length of fixed-length parameters (X'00')
6-m		ATTDPN	RDPN field supplied with an input message resulting in this SYMSMSG
m+1-n		ATTPRN	RPRN field supplied with an input message resulting in this SYMSMSG

## **SYSSTAT FM Header**

Table 64 shows the format of the SYSSTAT FM header.

*Table 64. SYSSTAT FM Header*

<b>Byte</b>	<b>Bits</b>	<b>Name</b>	<b>Content</b>
0		FMHL	Length
1	0	FMHC	
	1-7	FMHT	B'0000110'
2-3		FMH6CMD	X'0402'
4		FMH6MOD	
	0	FMH6LNSZ	B'0' 1-Byte length fields
	1-7	Reserved	
5		FMH6FXCT	Length of fixed-length parameters

---

## Part 6. CPI Communications and APPC/IMS

<b>Chapter 19. CPI Communications</b> . . . . .	395	Message Switching . . . . .	428
CPI-C Driven Application Programs . . . . .	395	Asynchronous Output Delivery . . . . .	430
SAA Resource Recovery Commit Processing . . . . .	395	APPC Transaction Security . . . . .	431
Normal Termination . . . . .	396		
Backout Processing . . . . .	396		
Abnormal Termination . . . . .	396		
Session Failure . . . . .	397		
Return Codes . . . . .	397		
System Restart/Resolve-in-Doubt Processing . . . . .	397		
CPI-C Application Program Recovery . . . . .	398		
Programming Requirements . . . . .	398		
Pseudonym Files . . . . .	398		
Distributed Syncpoint/Protected Conversations . . . . .	398		
Resource Recovery Services/MVS . . . . .	399		
Activating Protected Conversations . . . . .	402		
<b>Chapter 20. Administering APPC/IMS and LU 6.2</b>			
<b>Devices</b> . . . . .	405		
APPC/IMS Overview . . . . .	405		
APPC/IMS Application Program Interface . . . . .	406		
Implicit API . . . . .	406		
Explicit API . . . . .	407		
APPC/IMS Application Programs . . . . .	407		
Standard IMS Application Programs . . . . .	407		
MSC and Standard IMS Application Programs . . . . .	408		
Modified IMS Application Programs . . . . .	409		
MSC and Modified IMS Application Programs . . . . .	410		
CPI Communications Driven Application Programs . . . . .	410		
Using the MOD Name and LTERM Interface . . . . .	411		
Migrating Applications from the IMS Adapter to APPC . . . . .	412		
Establishing APPC/IMS . . . . .	412		
TP_Profile . . . . .	412		
MVS System Data File Manager Utility (ATBSDFMU) Example . . . . .	414		
Outbound LU Specification . . . . .	415		
Side Information — Outbound . . . . .	415		
PARMLIB Member . . . . .	416		
APPC/MVS Timeout Service . . . . .	417		
APPC/MVS Error Extract Service . . . . .	418		
Initializing and Changing LU 6.2 Descriptors . . . . .	418		
Using MSC in an APPC/IMS Environment . . . . .	419		
Recovering APPC Transactions in an MSC Environment . . . . .	420		
Recoverable versus Nonrecoverable Transactions . . . . .	420		
Local APPC Transaction Discardability versus Nondiscardability . . . . .	421		
OTMA Transaction Discardability versus Nondiscardability . . . . .	421		
Transaction Processing Point of Failure . . . . .	421		
Recoverability Flows of LU 6.2 Transactions . . . . .	424		
Planning for XRF and APPC . . . . .	426		
Transaction Retry Characteristics . . . . .	426		
Qualifying Network LU Names . . . . .	427		
DFSAPPC System Service . . . . .	427		





---

## Chapter 19. CPI Communications

This chapter introduces CPI Communications driven application programs and distributed Syncpoint protected conversations.

### **In this Chapter:**

- “CPI-C Driven Application Programs”
- “Distributed Syncpoint/Protected Conversations” on page 398

---

### **CPI-C Driven Application Programs**

A CPI Communications driven application program can use IMS-managed resources in two ways:

- Using the SQL calls to access DB2 UDB for z/OS through the IMS External Subsystem (ESS) Attach Facility. If the DB2 UDB for z/OS resource translation table (RTT) is not used, the initial DB2 UDB for z/OS plan name is the application program name. After the APSB call, the DB2 UDB for z/OS plan name is the PSB name specified in the APSB call.
- Using the APSB call to allocate IMS resources.

You can use the following SAA resource recovery calls when you want an application program to commit or back out changes to IMS or DB2 UDB for z/OS resources:

- Use the Commit call (SRRRCMIT) to commit changes.
- Use the Backout call (SRRBACK) to back out changes.

The following topics provide additional information about CPI Communications driven application programs:

- “SAA Resource Recovery Commit Processing”
- “Normal Termination” on page 396
- “Backout Processing” on page 396
- “Abnormal Termination” on page 396
- “Session Failure” on page 397
- “Return Codes” on page 397
- “System Restart/Resolve-in-Doubt Processing” on page 397
- “CPI-C Application Program Recovery” on page 398
- “Programming Requirements” on page 398
- “Pseudonym Files” on page 398

### **SAA Resource Recovery Commit Processing**

By issuing the SRRRCMIT call, an application program tells IMS to commit changes to database resources:

- Issue the SRRRCMIT call when the application program updates any IMS resources or accesses DB2 UDB for z/OS resources.
- Reissue the SRRRCMIT call after making any subsequent changes to an IMS or DB2 UDB for z/OS resource.
- Issue the SRRRCMIT call before terminating your application program.

## SAA Resource Recovery Commit Processing

If the application program terminates with any uncommitted changes to IMS resources, IMS attempts to commit these changes. Dangling conversations are deallocated abnormally.

When you issue the SRRCMIT call, IMS gets control and generates an internal sync-point call (if the conversation was not allocated with SYNCLVL=SYNCPT). All database changes are committed. All messages inserted to alternate PCBs (program control blocks) are sent to their final destination.

### Normal Termination

In IMS, normal termination occurs when an application program terminates without abending. For a CPI Communications driven application program, an implicit commit occurs.

**Definition:** An *implicit commit* occurs when the application program does not issue an explicit call to commit the current transaction, but one of the following occurs:

- The application program terminates normally.
- For a standard or modified DL/I application program, the application program issues a GU call to the message queue.

### Backout Processing

Transaction updates are backed out when any of the following occurs:

- Backout is issued by the application program.
- The application program terminates abnormally.
- The application program terminates normally, but the implicit commit fails.
- IMS resources are in flight during IMS system restart.

The backout consists of the following actions:

- All database updates are backed out.
- All messages inserted to non-express alternate PCBs are discarded.
- All messages inserted to express PCBs that have not been enqueued are discarded.
- The APPC/MVS verb ATBCMTP TYPE=ABEND is issued.<sup>27</sup>

The application program tells IMS that a backout is required by issuing SRRBACK or by terminating abnormally.

### Abnormal Termination

IMS considers an application program to have terminated abnormally if either of the following occurs:

- The implicit commit fails.
- The application program abends.

When your application program abends, IMS backs out to the last IMS sync point.

---

27. Issuing the verb ATBCMTP causes all LU 6.2 conversations associated with this TPI to terminate with CM\_DEALLOCATE\_ABEND.

## Session Failure

If any LU 6.2 session fails during the conversation, you can choose to end the application program or continue processing. IMS TM is not involved and places no restrictions on your choice of committing or backing out updates. The application programmer makes this decision.

Because IMS TM is not informed of the session failure, it takes no action. The normal processing rules for commit and backout apply.

## Return Codes

Your application program receives return codes from IMS on the SAA resource recovery SRRCMIT and SRRBACK calls.

Your application program can receive the following return codes:

### RR\_OK

The backout or commit operation completed successfully. All protected resources if backed out have been returned to their previous sync point; if they have been committed, they have advanced to a new sync point, and all changes made during the logical unit of work have been made permanent.

### RR\_PROGRAM\_STATE\_CHECK

A non-CPI Communications driven IMS application program issued an SAA resource recovery Commit call. No commit or backout has been performed.

### RR\_BACKED\_OUT

A resource manager voted “no” during sync point processing. The sync point was initiated by the SAA resource recovery Commit call. The resource state is backed out for all resources.

## System Restart/Resolve-in-Doubt Processing

**Definition:** After a system failure, a key part of restart processing is known as *resolve-in-doubt* processing. If the system fails, IMS determines whether to perform resolve-in-doubt processing for IMS-protected resources. Examples of IMS-protected resources are:

- IMS DB databases
- DB2 UDB for z/OS databases
- IMS TM message-queue messages

If the IMS system fails before the transaction completes phase one of the two-phase commit process (sync point), IMS backs out during IMS restart. Backout includes transactions that were processing at the time of failure.

If the transaction completes phase one of the commit process, resolve-in-doubt processing can take place during IMS restart. If only IMS resources are affected, commit processing occurs. If DB2 UDB for z/OS resources are involved, resolve-in-doubt processing occurs between IMS and DB2 UDB for z/OS.

No transactions using explicit CPI Communications driven application programs are preserved across an IMS restart.

### CPI-C Application Program Recovery

No recovery processing exists for application programs using the explicit CPI Communications driven interface. IMS discards all CPI Communications driven transactions at restart regardless of their state at the time of failure. Application program designers should be aware of the SAA resource recovery resynchronization functions and consider the impact on their application program designs.

The application program should provide full integrity by issuing a SAA resource recovery Commit or Backout call for session failures. Application programs that require recovery assistance must be standard DL/I application programs.

**Related Reading:** For more information on IMS DL/I calls, see *IMS Version 9: Application Programming: Database Manager*.

### Programming Requirements

The CPI Communications driven application program activates IMS sync point processing by issuing the SRRCMIT and SRRBACK calls. The calls that initiate implicit sync point (DL/I GU to the message queue, CHKP, and SYNC) are invalid for CPI Communications driven application programs, and receive status AD (function parameter invalid).

If you allocate a conversation with SYNCLVL=NONE or SYNCLVL=COMMIT, include module DFSCPIR0 with your application program in the bind step. Including this module allows your application program to resolve the external references for SRRCMIT and SRRBACK.

No language-unique programming concerns exist in IMS for the SAA resource recovery interface.

### Pseudonym Files

APPC/IMS uses APPC/MVS services to provide SAA resource recovery support. APPC/MVS does not provide SAA resource recovery pseudonym files. However, you can create your own pseudonym files.

**Related Reading:** For sample pseudonym files, see *SAA CPI Resource Recovery Reference*. These sample pseudonym files include examples on how to define working storage in the different languages.

Briefly, programmers of different languages need to define the following:

- IMS TM C programmers need to define z/OS as their operating system.
- IMS TM COBOL programmers must define their buffers in working storage.
- IMS TM FORTRAN programmers must define EXTERNAL statements for SRRCMIT and SRRBACK.

---

## Distributed Syncpoint/Protected Conversations

Distributed syncpoint/protected conversations are covered in the following topics:

- “Resource Recovery Services/MVS” on page 399
- “Activating Protected Conversations” on page 402

## Resource Recovery Services/MVS

Resource Recovery Services/MVS (RRS/MVS) is the sync-point manager, coordinating the update and recovery of multiple protected resources. RRS/MVS controls how and when protected resources are committed by coordinating with the resource managers, such as IMS, that have registered with RRS/MVS.

RRS/MVS supports the Common Programming Interface for Resource Recovery (CPI-RR), an element of the SAA CPI that specifies resource recovery and coordinates recovering local and distributed resources.

### Definitions:

- A *protected resource* is a set of local or distributed data that is updated in a synchronized and controlled manner. In the APPC environment, a protected resource is a resource that is updated in an allocated conversation in which SYNCLVL=SYNCPT has been specified.
- A *resource manager* is a product, such as IMS, that owns protected data resources that are updated in an APPC conversational environment in which SYNCLVL=SYNCPT has been specified. IMS acts as a resource manager for DL/I data, Fast Path data, and the message queues.

The three participants in resource recovery include:

- RRS/MVS (sync-point manager)
- Resource manager (such as IMS or DB2 UDB for z/OS)
- Application program

Figure 58 shows the three participants in the resource recovery process, and their interaction.

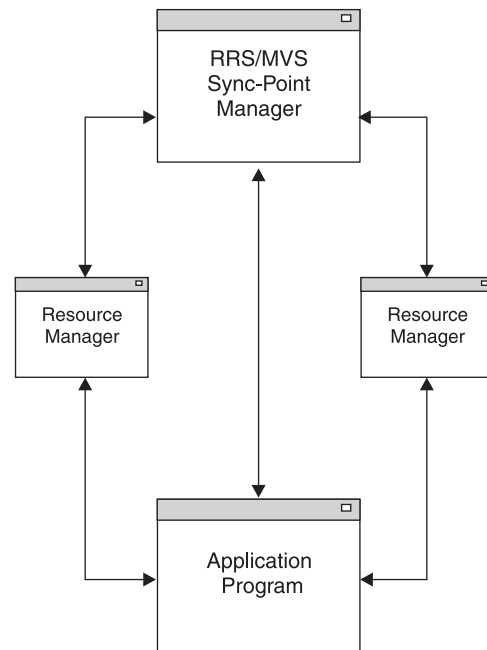

Figure 58. Participants in Resource Recovery

### The Two-Phase Commit Protocol

**Definition:** The *two-phase commit protocol* is a process involving RRS/MVS and the resource manager that ensures that updates made to a set of resources by an

## Distributing SYNC-Point/Protected Conversations

application program are either all made or none made. The application program decides whether to commit its changes to the resources; this commit is made to RRS/MVS, which polls all of the resource managers as to the feasibility of the commit call. Each resource manager votes whether to commit the updates. This is called *phase 1* of the two-phase commit protocol.

After RRS/MVS has gathered the votes, *phase 2* begins. If all votes are to commit the updates, then the phase 2 action is to commit; otherwise, phase 2 results in a backout of the updates. System failures, communication failures, resource manager failures, or application program failures are not barriers to completing the two-phase commit protocol.

### Definitions:

- A *unit of recovery* is a unit of work that spans one commit (synchronization) point to the next commit point.
- Units of recovery are termed *inflight* between the time they are created (or the previous sync point) until the resource manager votes to commit the updates. If the resource manager fails while units of recovery are inflight, the resource manager backs out all of the database updates on the subsequent start.
- Units of recovery are termed *indoubt* between the time when the resource manager votes to commit the updates and the time when the sync-point manager calls the resource manager to do the commit. If IMS fails while units of recovery are indoubt, IMS holds the database updates until they are resolved.

## **Local-Resource Recovery Versus Distributed-Resource Recovery**

### Definitions:

- In a *local-resource recovery environment*, the recovery participants reside on the same z/OS system.
- In a *distributed-resource recovery environment*, the recovery participants and the updated resources are scattered across multiple systems. In a distributed-resource recovery environment, the APPC/PC (APPC/protected conversation) resource manager is used to provide the communications for the sync-point calls to remote systems.

Figure 59 on page 401 illustrates how a distributed recovery environment operates.

## Distributing SYNC-Point/Protected Conversations

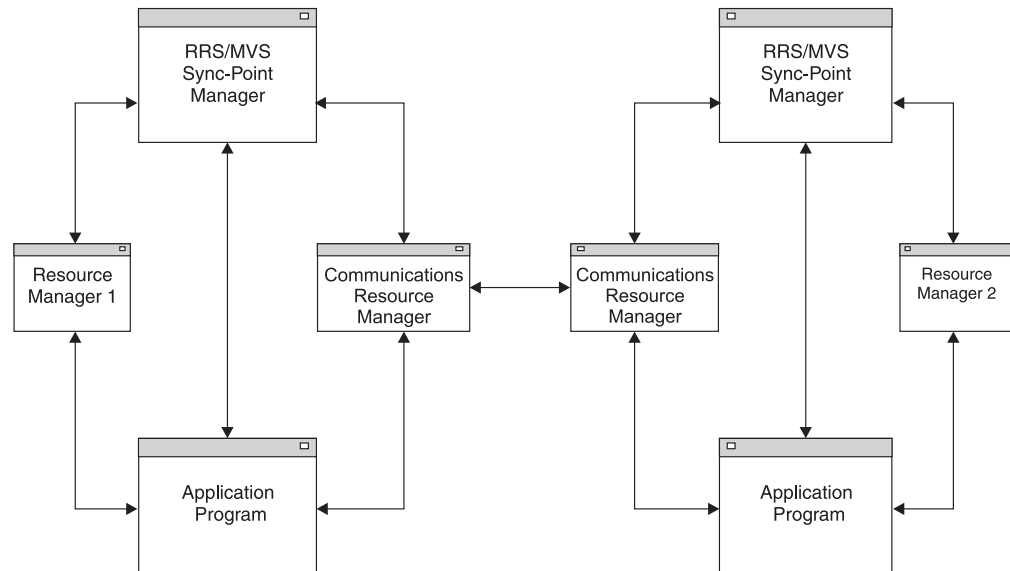

Figure 59. Distributed Resource Recovery

### IMS as a Resource Manager

In this environment, a resource manager controls a protected resource. In general, a resource manager does the following:

- Provides an application programming interface (API) to allow application programs to access its resources
- Logs changes to data before making the changes permanent
- Logs unit of work status
- Participates in the commit or backout actions for updated resources
- Contains recovery mechanisms to restore data to a previous state

For its own resources, IMS is both the sync-point manager and the resource manager.

Within the two-phase commit protocol, IMS must do each of the following:

- Register with RRS/MVS as a resource manager
- Participate in the sync-point process
- Express interest in the unit of work
- Recover its unit of work status after an outage

**Registration:** A component of RRS/MVS provides registration services so that IMS can identify itself as a resource manager. By registering, IMS is provided a set of services to aid in maintaining resource consistency associated with the protected conversation.

IMS registers each time a control region is started for a DB/DC active system on a z/OS system with the recovery platform support. In an XRF environment, the active system registers during its restart. The alternate system registers at the time of takeover. No registration or participation occurs from an RSR tracking system.

## Distributing SYNC-Point/Protected Conversations

**Expressing Interest:** In addition to registering and supplying resource manager exit routines for specific stages of the two-phase commit protocol, IMS must also express interest in participating in the two-phase commit process for a particular unit of recovery.

**Resolution of Incomplete Interests:** In the event of an IMS or z/OS outage, during the IMS restart, the incomplete UR expressions of interest must be resolved.

RRS/MVS maintains unit of recovery information (such as identifier, state, and resource manager private data), which RRS/MVS presents to the restarting resource managers that previously expressed interest.

**Sync-Point Participation:** After IMS successfully registers and restarts, it supplies addresses of its exit routines to RRS/MVS. Several exit routines (such as prepare, commit, and backout) represent specific points in the two-phase commit protocol, which IMS can call to participate in the process.

## Activating Protected Conversations

z/OS uses a construct with RRS/MVS called a context.

**Definition:** A *context* is the entity for which resource managers perform services, to which they allocate resources and lock ownership, and in which they can express interest in participating in the protocol to ensure that the resource is updated in an orderly manner.

The type of context that the resource manager creates, owns, and manipulates is called the *private context*. A resource manager can create a context on behalf of another resource manager. RRS/MVS uses the private context to identify an application program's unit of work to maintain information for the resource manager concerning which of their resources are associated with the unit of work.

### APPC as the Communications Manager

When APPC is the communications manager, RRS/MVS support is activated when a conversation is allocated with SYNCLVL=SYNCPT. This type of conversation is a protected conversation.

When SYNCLVL=SYNCPT is specified, APPC acquires a private context on behalf of IMS. IMS provides its resource manager name to APPC in its identity call. APPC provides the private context to IMS as the message header. IMS, using this context, then assumes the role of a participant in the two-phase commit process with the sync-point manager, RRS/MVS.

In addition to the SYNCLVL=SYNCPT, the keyword ATNLOSS=ALL must be specified in the VTAM definition file for whichever LUS the user wishes to enable for protected conversations.

### Using OTMA with Protected Conversations

In an OTMA environment, OTMA is not a resource manager registered with RRS/MVS. The process remains an inter-process protocol between a server (IMS) and a number of clients (application programs). Therefore, OTMA cannot obtain a private context token to pass to IMS, as APPC does. The client-adaptor code that uses OTMA is responsible for obtaining and owning a private context, and for providing the context ID. In messages passed between the partners, the context-ID field contains the context token (if it is a protected conversation).



When IMS finds the context-ID in the message, IMS assumes the role of a participant in the two-phase commit process, as it does in the APPC environment.

**Related Reading:** For more information on these OTMA topics, see *IMS Version 9: Open Transaction Manager Access Guide and Reference*.

### **XRF and Protected Conversations**

Running protected conversations (using RRS/MVS with either APPC/PC or OTMA) in an IMS-XRF environment does not guarantee that the alternate system can resume and resolve any unfinished work started by the active system. A failed resource manager must re-register with its original RRS/MVS system if the RRS/MVS system is still available when the resource manager restarts. Only if the RRS/MVS on the active system is not available can an XRF alternate system register with another RRS/MVS in the sysplex and obtain the incomplete unit of recovery data of the failing active system. Because IMS retains indoubt units of recovery until they are resolved, it is recommended that a switch back to the active system be done as soon as possible to obtain the unit of recovery information and to resolve and complete all the work of the resource managers.

### **RSR and Protected Conversations**

Active systems tracked in an RSR environment by a remote system can process protected conversations with APPC/PC or OTMA, although it is necessary to resolve indoubt units of recovery using commands after a takeover. Most likely, the remote site is not part of the active sysplex, and no means exists for the new IMS system to acquire unfinished unit of recovery information from RRS/MVS. IMS provides commands to investigate protected conversation work and to resolve it if necessary.

## Activating Protected Conversations

---

## Chapter 20. Administering APPC/IMS and LU 6.2 Devices

These topics introduce APPC/IMS and describe how to administer APPC/IMS and LU 6.2 devices.

### **In this Chapter:**

- “APPC/IMS Overview”
- “APPC/IMS Application Program Interface” on page 406
- “APPC/IMS Application Programs” on page 407
- “Establishing APPC/IMS” on page 412
- “Initializing and Changing LU 6.2 Descriptors” on page 418
- “Using MSC in an APPC/IMS Environment” on page 419
- “Recovering APPC Transactions in an MSC Environment” on page 420
- “Planning for XRF and APPC” on page 426
- “Transaction Retry Characteristics” on page 426
- “Qualifying Network LU Names” on page 427
- “DFSAPPC System Service” on page 427
- “APPC Transaction Security” on page 431

---

### **APPC/IMS Overview**

APPC/IMS, a part of IMS TM, lets you use the CPI Communications interface to build CPI application programs. APPC/IMS allows distributed and cooperative processing between IMS and systems that have implemented APPC as shown in Figure 60 on page 406. APPC/IMS delivers support for APPC with facilities provided with APPC/MVS.<sup>28</sup> APPC/IMS supports the CPI resource recovery Commit (SRRCMIT) and Backout (SRRBACK) calls for IMS-managed local resources. These protected resources include:

- IMS TM message-queue messages
- IMS DB databases
- DB2 UDB for z/OS databases

APPC/IMS also supports the existing IMS DL/I application programming interface (API) enabling application programs to use LU 6.2 communications without the function of the CPI Communications interface. This allows most existing applications to continue to function with the APPC/IMS support of LU 6.2.

---

28. The APPC/IMS interface is provided by APPC/MVS and supports the CPI Communications interface. IMS TM supports the CPI resource recovery interface.

## Introducing APPC/IMS

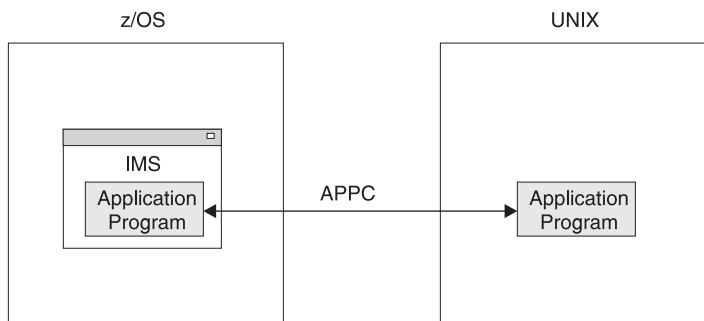

Figure 60. APPC Support for IMS

### Definitions:

- Within the context of administering IMS TM, “transaction programs,” “applications,” “application programs,” and “programs” are synonymous.
- Within the context of administering APPC/IMS and LU 6.2 devices, “APPC application programs” are synonymous with “LU 6.2 application programs.”
- “LU 6.2 transactions” are those that originate from an LU 6.2 application program.

### Recommendations: For APPC/IMS, do the following:

- Schedule your IMS standard or modified application programs entered from LU 6.2 remote systems using MSC. Be aware that CPI-C driven application programs cannot have transactions that execute on remote systems.
- Define your APPC/IMS LUs for use by APPC/MVS, as well as by any APPC application program.
- Use the LTERM and the MOD name in the first segment of your message. Use the LTERM to change the destination for your output to a non-LU 6.2 device. Use the MOD name to format error messages.
- Use a network-qualified LU name. You do not need to have unique names for the LUs on different systems.

IMS dependent regions are automatically defined to APPC as subordinate address spaces of the IMS Scheduler. An IMS BMP cannot be defined as an ASCH controlled application. It may use explicit conversation services through the IMS base LU.

IMS manages the APPC/IMS buffers automatically; no definition is necessary. No special considerations are needed for EMH.

---

## APPC/IMS Application Program Interface

APPC/IMS has two distinct application program interfaces (APIs): the implicit and explicit interfaces. The same application program can use both APIs.

The following topics provide additional information:

- “Implicit API”
- “Explicit API” on page 407

### Implicit API

The *implicit API* is an extension of the IMS standard DL/I API (call xxxTDLI). It allows IMS application programs to communicate with LU 6.2 application

programs without being sensitive to LU 6.2 protocols and without requiring the programmer to have any knowledge of LU 6.2. APPC/IMS provides functions not normally available to an LU 6.2 application program: message queuing, and automatic asynchronous message delivery and recovery. Existing IMS transactions use the implicit API to communicate with APPC.

Implicit API messages are placed on the IMS message queues or the Fast Path expedited message handling (EMH) buffers for Fast Path transactions. The originating IMS determines whether to mark the input messages as discardable or nondiscardable.

When the implicit API is used, IMS issues all required CPI Communications calls. The application program interacts strictly with the IMS message queues or the Fast Path EMH buffers.

### Explicit API

The *explicit API* is the CPI Communications API and is available to any IMS application program.<sup>29</sup> The application program makes calls to APPC using the CPI Communications interface without using IMS. These CPI calls are handled directly by APPC/MVS. Messages sent or received by the CPI Communications interface are not stored on the IMS message queues or in the EMH buffers, and these messages are not available for transaction restart. No IMS-provided functions are involved for these messages.

---

## APPC/IMS Application Programs

APPC/IMS has three different types of application programs:

### Standard

No explicit use of CPI Communications facilities.

### Modified

Uses the I/O PCB to communicate with the original input terminal. Uses CPI Communications calls to allocate new conversations and to send and receive data.

### CPI Communications driven

Uses CPI Communications calls to receive the incoming message and to send a reply on the same conversation. Uses the DL/I APSB call to allocate a PSB to access IMS databases and alternate PCBs.

You can schedule your standard and modified application programs locally and remotely using MSC. The logic for local application programs differs from the logic for remote application programs. In the following topics, the differences are described.

## Standard IMS Application Programs

Standard IMS application programs use the existing IMS call interface. Application programs that use the IMS standard API can take advantage of the LU 6.2 protocols. Standard IMS application programs use a DL/I GU call to trigger a sync point and to get the incoming transaction. These standard IMS application programs also use DL/I ISRT calls to generate output messages to the same or

---

<sup>29</sup> You can also use z/OS ATBxxx call services. See *MVS Programming: Writing Transaction Programs for APPC/MVS* for information on using these calls.

## APPC/IMS Application Programs

different terminals, which can be LU 6.2 terminals.<sup>30</sup>The identical program can work correctly for both LU 6.2 and non-LU 6.2 terminal types. IMS generates the appropriate calls to APPC/MVS services.

IMS provides the following services for standard IMS application programs:

- Receives incoming transaction from an LU 6.2 application program
- Calls the Input Message Routing exit routine
- Schedules transactions into local and remote IMS dependent regions
- Provides necessary transaction recoverability
- Provides necessary transaction rollback and retry
- Provides integration of IMS-controlled conversation flows with database updates during sync point for all APPC Sync\_Level options (NONE, CONFIRM, SYNCPT)
- Provides all needed LU 6.2 calls to APPC/MVS services
- Sends either synchronous or asynchronous output to an LU 6.2 application program
- Keeps asynchronous output on IMS message queue until successful transmission
- Allocates new LU 6.2 conversations for messages inserted to alternate PCBs using the DL/I ISRT call

Existing application programs that are sensitive to a terminal's hardware characteristics, such as cursor position or MFS format names, might need to be changed to communicate with LU 6.2 application programs.

**Restrictions:** LU 6.2 Synchronous Conversations with Implicit Transactions.

1. If a LU 6.2 synchronous conversation implicit transaction initializes other transactions (program-to-program switch), an express PCB can not be used to do the ISRT. An express PBC causes race conditions to occur and the output may randomly return to the inputting terminal on a new asynchronous conversation with TPNAME DFSASYNC. The original conversation may not be deallocated.
2. If a transaction initializes more than one child transaction, which in turn may initialize other transactions, and one of the child transactions provides the response, the result is unpredictable.

Depending on the execution sequence of these transactions the LU can receive a DFS2082 message with the response sent to the default TP name DFSASYNC or the LU receives the response and no DFS2082 message is issued.

## MSC and Standard IMS Application Programs

When an APPC application program enters an IMS transaction that executes on a remote IMS, an LU 6.2 conversation is established between the APPC application program and the local IMS. The local IMS is considered the partner LU of the LU 6.2 conversation. The transaction is then queued on the remote transaction queue of the local IMS. From this point on, the transaction goes through normal MSC processing. After the remote IMS executes the transaction, the output is returned to the local IMS, and is then delivered to the originating LU 6.2 application program.

The originating (local) IMS provides the following services:

- Receives incoming transaction from an LU 6.2 application program

---

<sup>30</sup> A non-message-driven BMP is considered a standard IMS application program when it does not use the explicit API.

- Calls the Input Message Routing exit routine
- Queues the transaction to its remote transaction queue
- Sends the transaction across the MSC link
- Receives the transaction response
- Sends either synchronous or asynchronous output to an LU 6.2 application program

The remote IMS provides the following services for the remote standard application program:

- Receives the incoming transaction from the partner IMS (originating or intermediate IMS) over the MSC link
- Schedules transactions into dependent regions
- Commits database changes at sync point
- Provides necessary transaction recoverability
- Provides necessary transaction rollback and retry
- Keeps transaction output on the IMS message queue until the transmission is successful
- Returns the transaction output to the local IMS over the MSC link

**Restriction:** MSC is not supported if the originating LU 6.2 conversation is allocated with SYNCLVL=SYNCPT.

### Modified IMS Application Programs

Modified IMS application programs use a DL/I GU call to retrieve the incoming transaction and to trigger a sync point. These modified IMS application programs also use DL/I ISRT calls to generate output messages to the same or different terminals, which can be LU 6.2 terminals.<sup>31</sup> Unlike standard IMS application programs, modified IMS application programs use CPI Communications calls to allocate new conversations, and to send and receive data. IMS has no direct control of these CPI Communications conversations.

Modified IMS transactions are indistinguishable from standard IMS transactions until program execution. In fact, the same application program can be a “standard IMS” application on one execution, and a “modified IMS” application on a different execution. The distinction is simply whether the application program has used CPI Communications resources.

IMS provides the following services for modified IMS application programs:

- Receives incoming transactions from LU 6.2 application programs
- Schedules transactions into local and remote dependent IMS regions
- Appropriate transaction recoverability before transaction scheduling
- Provides integration of IMS-controlled conversation flows with database updates during sync point for APPC Sync\_Level options (NONE, CONFIRM, SYNCPT)
- Provides all necessary LU 6.2 calls to APPC/MVS services for IMS-controlled LU 6.2 conversations
- Sends either synchronous or asynchronous output to LU 6.2 application programs

---

<sup>31</sup> A non-message-driven BMP is considered a modified standard IMS application program when it uses the explicit API.

## APPC/IMS Application Programs

- Keeps asynchronous output on the IMS message queue until successful send occurs
- Allocates new LU 6.2 conversations for any messages inserted to alternate PCBs using the DL/I ISRT calls

IMS does not provide any services for conversations explicitly allocated by the application program. Explicitly allocated conversations need to be deallocated if a program abend occurs.

## MSC and Modified IMS Application Programs

When an APPC program enters an IMS transaction that executes on a remote IMS, an LU 6.2 conversation is established between the APPC program and the local IMS. The local IMS is considered the partner LU of the LU 6.2 conversation. The transaction is then queued on the local IMS's remote transaction queue. From this point on, the transaction goes through normal MSC processing. After the remote IMS executes the transaction, the output is returned to the local IMS, and then delivered to the originating LU 6.2 program.

The originating (local) IMS provides the following services:

- Receives incoming transaction from an LU 6.2 application program
- Calls the Input Message Routing exit routine
- Queues the transaction to its remote transaction queue
- Sends the transaction across the MSC link
- Receives the transaction response
- Sends either synchronous or asynchronous output to an LU 6.2 application program

The remote IMS provides the following services for the remote modified application program:

- Receives the incoming transaction from the partner IMS (originating or intermediate system) over the MSC link
- Schedules transactions into dependent regions
- Appropriate transaction recoverability before transaction scheduling
- Commits database changes at sync point
- Provides necessary transaction recoverability
- Provides necessary transaction rollback and retry
- Keeps transaction output on the IMS message queue until the transmission is successful
- Returns the transaction output to the local IMS over the MSC link

**Restriction:** MSC is not supported if the originating LU 6.2 conversation is allocated with SYNCLVL=SYNCPT.

## CPI Communications Driven Application Programs

CPI Communications driven application programs are defined only in the APPC/MVS TP\_Profile data set; they are not defined to IMS. Their definition is dynamically built by IMS when a transaction is presented for scheduling by APPC/MVS based on the APPC/MVS TP\_Profile definition after IMS restart. The definition is keyed by TP name. APPC/MVS manages the TP\_Profile information.

When a CPI Communications driven transaction program requests a PSB, the PSB must already be defined to IMS using the APPLCTN macro for SYSGEN and using



PSBGEN/ACBGEN when APPLCTN PSB= is specified. When APPLCTN GPSB= is specified, a PSBGEN/ACBGEN is not required.

CPI Communications driven application programs must use CPI Communications calls to accept the incoming conversation and to send a reply on the same conversation. The DL/I GU call is not used to retrieve the initiating transaction from the LU 6.2 application program. No IMS resources are allocated when the application program is scheduled. Instead, the application program can use the DL/I APSB call to allocate a PSB that provides access to IMS databases and to alternate PCBs. A CPI Communications driven application program can send messages to other terminals (either LU 6.2 or non-LU 6.2) or other IMS transactions (either local or remote) by inserting to an alternate PCB, after allocating the appropriate PSB. Both the explicit and implicit API can be used on the same application program.

IMS provides the following services for CPI Communications driven application programs:

- Schedules the transaction.  
IMS does not receive input before scheduling. It does not interact with the conversation at any time other than to possibly reject the inbound allocate request. If IMS rejects the inbound allocate request, the transaction is not scheduled.
- Provides sync point of local resources.
- Schedules PSB if called by application program.
- Processes calls to alternate or database PCB made by the application program.

### **Related Reading:**

- For more information on RRS/MVS, see “Resource Recovery Services/MVS” on page 399.
- For more information on CPI Communications driven application programs, see:
  - Chapter 19, “CPI Communications,” on page 395
  - *IMS Version 9: Application Programming: Database Manager*
  - *IMS Version 9: Application Programming: Transaction Manager*
  - *IMS Version 9: Application Programming: Design Guide*

## **Using the MOD Name and LTERM Interface**

Your LU 6.2 application program can use an interface to emulate MFS. For example, the application program can use the MOD name to communicate with IMS to specify how an error message could be formatted. For non-LU 6.2 application programs, the MOD name is given to the MFS formatting modules in IMS; for LU 6.2 application programs, the MFS modules are not called, and the MOD name is given to the LU 6.2 Edit exit routine (DFSLUEE0) as a parameter. The LU 6.2 Edit exit routine can do whatever the programmer specifies with the MOD name, such as format an error message.

Your LU 6.2 application program uses the LU name to send data to an LU 6.2 application program. However, if you want to send data to a non-LU 6.2 device such as a printer, you can use the LTERM instead of the LU name.

The Initialization exit routine (DFSINTX0) can be used to create a user table of MOD names that you might want to use for formatting messages, and LTERMs that you might want to use as printers. This user table can be used by DFSLUEE0 to find the appropriate MOD name or LTERM for your application program.

## APPC/IMS Application Programs

LU 6.2 application programs can send both the LTERM and the MOD name in the first segment of the message. The LU 6.2 Edit exit routine (DFSLUEE0) checks the contents of the first message segment. Based on the information it finds in a user table, the exit routine decides whether to return the LTERM and the MOD name to IMS. IMS saves the LTERM and the MOD name in the I/O PCB. For formatting output, IMS provides the address of the MOD name in the first segment of the message to the LU 6.2 Edit exit routine (DFSLUEE0). For changing the destination to a non-LU 6.2 device, IMS provides the LTERM in the first segment of the message to the LU 6.2 Edit exit routine (DFSLUEE0). The Initialization exit routine (DFSINTX0) can be used to create the user table. This exit routine must pass the address of the user table to IMS, and IMS passes the address to DFSLUEE0.

### Migrating Applications from the IMS Adapter to APPC

Applications can, in most instances, be migrated from using the IMS 6.1 Adapter to APPC without change to the application. However, there are some small differences between IMS 6.1 Adapter and APPC that you should be aware of:

- APPC does not support MFS.
- IMS 6.1 Adapter uses IMSASYNC as the default TP-Name for asynchronous conversations, while APPC uses DFSASYNC as the default TP-Name for asynchronous transactions. Therefore, the client (whether IMS or non-IMS) needs to have DFSASYNC defined as the TP-Name in its system.

---

## Establishing APPC/IMS

Before activating APPC/IMS, an IMS system definition is needed to specify MVS 4.2 as the third parameter of the SYSTEM keyword for the IMSCTRL macro. CPI Communications driven application programs and LU 6.2 application programs cannot be defined in a system definition. LU 6.2 application programs are only defined to VTAM.

Start APPC/IMS by specifying APPC=Y on the IMS startup parameter. The default is APPC=N. When 'N' is specified, a connection to APPC/MVS services is not established during IMS initialization. When 'Y' is specified, IMS establishes a connection with APPC/MVS during IMS initialization. The /START APPC command overrides APPC=N.

### TP\_Profile

The TP\_Profile is a VSAM data set owned by APPC/MVS and maintained by the MVS System Data File Manager utility (ATBSDFMU) or by the administrator using TSO/ISPF dialogs. The purpose of the TP\_Profile entries is to provide attribute information for TP names.

**Related Reading:** For more information on this utility, see *MVS Programming: Writing Transaction Programs for APPC/MVS*.

CPI Communications driven application programs must be defined in the APPC/MVS TP\_Profile. IMS system-defined transaction codes can optionally be defined in a TP\_Profile. The existence of an IMS definition (in the IMS GEN or by online change) causes the transaction to be considered a standard DL/I or modified-standard application.



## Establishing APPC/IMS

3. A list of TP\_Profiles is displayed. Select **A** to add a new TP\_Profile or **E** to edit an existing TP\_Profile. If you are adding a TP\_Profile, you must supply a scheduler name. This name was set at IMS installation time. The recommended name is IMS.
4. After the general TP\_Profile characteristics are supplied, the ISPF editor panel is displayed. Enter DFSTPROF on the command line to display the IMS TP\_Profile Maintenance panel.
5. Supply IMS scheduler-dependent characteristics. Press enter to save your changes or PF3 or PF12 to cancel your changes. You can press PF1 for online help on fields supplied in this panel.

The TP\_Profile name is not available on all releases of TSO/E, so a value of “Not Available” is displayed. This does not suggest that a problem exists.

## MVS System Data File Manager Utility (ATBSDFMU) Example

The following example is an MVS System Data File Manager utility (ATBSDFMU) entry:

```
TPADD TPSCHED_EXIT(DFSTPPE0)
      TPNAME(INQUIRY_PART)
      SYSTEM
      ACTIVE(YES)
      TPSCHED_DELIMITER(##)
      TRANCODE=PART
      CLASS=1
      MAXRGN=1
                                     CPUTIME=0
      ##
```

In this example, the IMS section starts with TRANCODE=PART. The other control statements are shown for completeness.

**Related Reading:** For more information on using the MVS System Data File Manager utility (ATBSDFMU), see *MVS Planning: APPC Management*.

The IMS TP\_Profile parsing module, DFSTPPE0, performs validity checking and parses the input data in IMS. This module should be loaded into the STEPLIB data set of the step that adds the TP\_Profile. The MVS System Data File Manager utility (ATBSDFMU) requires that STEPLIB be APF authorized.

The following five keywords are used to add an IMS section to the TP\_Profile entry. The keyword-parameter sets must be separated by one or more blanks. The keyword-parameter sets must be specified between columns 1-72. An asterisk (\*) in column 1 indicates a comment.

### TRANCODE= 1 - 8 characters

Name of the IMS transaction code associated with this TP name consisting of alphanumeric or '#', '\$', '@'. IMS translates the TP name to the TRANCODE. IMS scans for valid characters (00640 character set). If invalid characters exist, IMS uses the default transaction code, IMSTRAN, instead of a transaction code with the non-00640 characters.

### CLASS= 1 - 999

Specifies the class used for scheduling. The default value is 1.

**Recommendation:** Define CPI transactions with a different message class from that used for non-CPI transactions. IMS handles all CPI transactions as priority zero within the transaction class.

**MAXRGN= 0 - 999**

Restricts the number of dependent regions that this CPI Communications driven transaction program can use. The default value is 1.

**RACF=NONE, CHECK, or FULL**

RACF=NONE causes IMS to call the Transaction Authorization exit routine (DFSCSTRN0).

RACF=CHECK causes IMS to call RACF for security checking when IMS receives a transaction (using RCLASS of TIMS or CIMS), but does not clone the security environment into the dependent region when the transaction executes.

RACF=FULL clones the security environment to the dependent region at execution time. Specifying this parameter and issuing the IMS command /SECURE APPC PROFILE enables APSB SAF Security for this CPI-C application program.

**CPUTIME= 0 - 1440**

Specifies the number of CPU seconds that the CPI-C program is allowed to use. If it exceeds the limit, it is terminated with ABENDU0240. This time limit protects against program loops, which locks resources from other applications. The default is 0, which is no limit.

You can use the TP\_Profile entry in two ways:

- To specify an IMS transaction code that is defined in the IMS. The CLASS and MAXRGN parameters in the TP\_Profile are ignored and the transaction values in IMS remain unchanged. The TP\_Profile entry provides mapping for a 64-character TPN into an 8-character transaction code.
- To specify an IMS transaction code that is not defined in the IMS. The IMS transaction code is a CPI Communications driven transaction, and is used as the load module name of the scheduled application program and the dynamically built transaction name.

When a TP\_Profile is not defined, IMS uses the first 8 bytes of the TPN translated to the IMS character set as the transaction code.

The allocate request is rejected if the transaction code is not valid.

## Outbound LU Specification

You can specify a defined APPC LU as the outbound LU. Otherwise, the default setting is BASE LU. Changing an outbound LU is useful because, when the outbound LU has status of disabled, IMS does not allocate the APPC conversation.

The outbound LU must be defined in the APPCPMxx member of the SYS1.PROCLIB library. To specify an LU as the outbound LU, use the OUTBND= parameter in the DFSDCxxx PROCLIB member. You can set the outbound LU by using the /CHANGE APPC OUTBND command. However, a restart sets the outbound LU to the value in the DFSDCxxx member, if specified. If it is not specified, the outbound LU is set to BASE LU.

## Side Information — Outbound

### Definitions:

- APPC/MVS *side information* supplies destination information, such as the name of the partner program, the name of the LU at the partner's node, and the logon mode name. CPI Communications provides a way to use system-defined values for these required fields; these system-defined values are the side information. This information can be used by an IMS application program allocating

## Establishing APPC/IMS

(establishing) an APPC conversation using CPI Communications, an IMS LU 6.2 descriptor, a DL/I change call (CHNG), or a DFSAPPC message switch.

System programmers supply and maintain the side information for CPI Communications programs.

- Side information is accessed by a *symbolic destination name*. The symbolic destination name, called *sym\_dest\_name* within the context of administering IMS TM, corresponds to an entry in the side information file containing the following information:

### **partner LU name**

Shows the name of the LU where the partner program is located. This LU name is any name for the remote LU that is recognized by the local LU for allocating a conversation. An example is a USERVAR name.

This LU name can be a 17-byte network-qualified LU name.

### **logon mode name**

Used by LU 6.2 to designate the properties for the session that will be allocated for the conversation. The properties include the class of service to be used on the conversation. The network administrator defines a set of mode names used by the local LU to establish sessions with its partners. The system programmer uses one of these values in a side table entry. An invalid mode name prevents a conversation from being allocated.

### **TP name**

*Transaction program (TP) name* specifies the name of the remote application program.

IMS and z/OS do not accept blank *sym\_dest\_name* values on the Initialize\_Conversation call.

**Related Reading:** For more information on APPC calls, see *Common Programming Interface Communications Specification*.

The default name for the side information file is SYS1.APPCSI. Define this file in the SYS1.PARMLIB(APPCLMxx) as shown in the following example.

```
SIDEINFO
  DATASET(SYS1.APPCSI)
```

The destination name, partner LU name, mode name, and TP name can be defined using the MVS System Data File Manager utility (ATBSDFMU) as shown in the following example.

```
SIADD
  DESTNAME(DESTX)
  TPNAME(LU62USER_TPX)
  MODENAME(APPCLMxx)
  PARTNER_LU(APPCLUX)
```

## PARMLIB Member

The APPC address space uses the APPCLMxx member of SYS1.PARMLIB. Define IMS as a local APPC component LU that is controlled by the APPC address space. The scheduler name is the same IMSID used in the IMSCTRL macro. When IMS identifies to APPC, it passes its IMSID as the scheduler name SCHED(IMS1) in APPC member APPCLMxxx. The following is an example of the APPCLMxx member:

```

LUADD
  ACBNAME(IMSLU62)
  SCHED(IMS1)
  BASE
  TPDATA(SYS1.APPCTP)
  TPLEVEL(SYSTEM)

```

For XRF add:

```
USERVAR=uservar_name ALTLU=luname
```

The LUADD option keywords are defined below:

**ACBNAME**=*local LUNAME of IMS*

**SCHED**=*IMS id*

**BASE***mandatory parameter*

**TPDATA**(*TP\_Profile dataset name*)

**TPLEVEL**(*system*) **suggested value**

**USERVAR**=(*useroar\_name*)

**ALTLU**=(*LUNAME*)

**Related Reading:** For more information on these keywords, see *MVS Planning: APPC Management*.

Communication between VTAM and its application programs requires an ACB (application control block) whose name must be identically defined in the SYS1.VTAMLST APPL statement and in the APPCPMxx LUADD statement ACBNAME parameter.

APPC manages the IMS ACB. When IMS identifies to APPC, APPC gives IMS the name of the APPC-managed ACB name (LUNAME). The APPC LUNAME is not defined in IMS, because IMS does not manage the ACB. The entries in the SYS1.PARMLIB member APPCPMxx include both the IMS scheduler name (IMSID) and the LUNAME ACBNAME(xxxxxxx) that ties an IMS to an LUNAME.

This ACBNAME must be different from the ACBNAME used by IMS for non-LU 6.2 terminals. APPC/MVS expects its LUs to be defined as VTAM resources so that these LUs can access the SNA network. A VTAM application program (APPL) definition macro must be coded for each APPC/MVS LU. LU 6.2 application programs are only defined to VTAM, not to IMS. The SYS1.VTAMLST member example follows:

```

IMSLU62 APPL ACBNAME=IMSLU62
          APPC=Y
          ...

```

## APPC/MVS Timeout Service

When APPC/MVS does not respond to an APPC call that is issued under the dependent region task control block (TCB) due, for instance, to a network delay,

## Establishing APPC/IMS

the dependent region hangs and the application transaction program cannot regain control. Using APPC/MVS Timeout Service, you can indicate the maximum time interval an application waits before terminating a conversation and regaining control from APPC/MVS callable services. The timeout feature is activated at startup by including the APPCIOT=xx parameter in IMS PROCLIB member DFSDCxxx, where xx specifies the number of minutes (between 0–1440) before the transaction is terminated. When a transaction is terminated due to timeout, messages DFS1965E and DFS1995E are sent to the MTO terminal and the z/OS console. The timeout value can be changed using the /CHANGE command.

For synchronous APPC conversations, if APPC timeout is active, then IMS uses ATBSTO5 service (SET\_TIMEOUT\_VALUE) to set the timeout value for each conversation.

For asynchronous APPC conversations, if APPC timeout is active, then IMS sets the timeout value when the conversation gets allocated. In either case, the timeout value is active until the conversation is deallocated, which occurs, in the case of IMS conversational transactions, when the IMS conversation ends.

Common Programming Interface Communications (CPI-C) transactions are not automatically supported by APPC/MVS Timeout service, but can exploit APPC/MVS Timeout service using ATBSTO5 service provided the proper coding is supplied.

### Related Reading:

- For more information on activating APPC/MVS Timeout Service, see *IMS Version 9: Installation Volume 2: System Definition and Tailoring*.
- For more information on programming MVS services, see *MVS Programming: Writing Transaction Programs for APPC/MVS*.

## APPC/MVS Error Extract Service

Whenever an APPC/MVS service call returns an unexpected return code, IMS issues APPC/MVS Error Extract Service call ATBEES3 with a DFS1995E prefix.

Related Reading: For more information on ATB return codes, see

- *z/OS V1R4: MVS System Messages, Vol 3 (ASB-BPX)*
- *z/OS V1R4: MVS Dump Output Messages*

---

## Initializing and Changing LU 6.2 Descriptors

LU 6.2 descriptors are optional, but they are required if you want to dynamically create queue control blocks and define processing options. LU 6.2 descriptors allow the system programmer to specify an LTERM that associates an output destination with an LU 6.2 application program. This allows the system programmer to change the application program's destination using alternate PCBs to LU 6.2 application programs, without requiring any application program coding changes. The application program uses an LTERM name as a symbolic destination; only the system programmer needs to be aware of the actual term associated with this name.

The LU 6.2 descriptor entry contains:

- LTERM name
- LU name of the destination of the LU 6.2 application program (overrides side information); this can be a network-qualified LU name up to 17 bytes in length



- APPC/MVS side information entry name; this parameter can be omitted
- VTAM mode table entry to be used (overrides side information)
- TP name to be scheduled (overrides side information)
- APPC conversation type (BASIC or MAPPED)
- APPC Sync\_Level options (NONE, CONFIRM)

Do not code a parameter and leave it blank (such as SIDE=b), or an error message is issued. Instead, omit the parameter completely.

**Related Reading:** For more information on coding these parameters, see *IMS Version 9: Installation Volume 2: System Definition and Tailoring*.

These LU 6.2 descriptor LTERMs are only for output and are never used by IMS as an LTERM name associated with an input message. DFSAPPC is an IMS-reserved name for the message switch facility.

The LU 6.2 descriptors are built as specified in IMS PROCLIB member DFS62DTx during IMS initialization. They can be added, deleted, or changed without restarting IMS. You can specify any number of descriptors. If an error occurs, the z/OS system console and the IMS JOBLIB record the error messages. IMS initialization continues regardless of any errors during descriptor initialization.

To add descriptors while IMS is running, you must first define the LU 6.2 descriptors in PROCLIB member DFS62DTx. Load the LU 6.2 descriptor from the IMS PROCLIB using the /START command. To delete descriptors, use the /DELETE command. To change descriptors, use the /CHANGE command.

**Related Reading:** For information on building descriptors, see *IMS Version 9: Installation Volume 2: System Definition and Tailoring*.

---

## Using MSC in an APPC/IMS Environment

APPC/IMS uses the services of APPC/MVS and MSC to provide the communication interface for an MSC configuration. Together, MSC and APPC/IMS allow:

- LU 6.2 programs to use the TP name of an IMS remote standard application program or an IMS remote modified application program. (The transaction is sent to the remote IMS and executes. The transaction's reply is sent across the MSC links to the local IMS and then on to the LU 6.2 application program.)
- A message switch to a remote logical terminal (LTERM) through the DFSAPPC System Service.
- Use of DFSAPPC for sending IMS remote transactions and data.
- Immediate or deferred program-to-program switching to an MSC-routed remote application program.

CPI Communications driven application programs cannot include transactions that execute on remote IMSs.

All IMS transaction types except Fast Path are supported: conversational, nonconversational, response mode, and nonresponse mode.

## Using MSC in an APPC/IMS Environment

MSC links that send or receive LU 6.2 transactions need larger link buffers to accommodate the processing of the LU 6.2 message prefix. IMS adds a prefix to the LU 6.2 message when it is sent over an MSC link. The minimum size of this prefix is 480 bytes.

**Related Reading:** For information on specifying the BUFSIZE parameter on the MSPLINK macro, see *IMS Version 9: Installation Volume 2: System Definition and Tailoring*.

To change the input message destination to any IMS local or remote destination after a message is received but before it is processed, use the Input Message Routing exit routine, DFSNPRT0.

**Definitions:** Using MSC with APPC/IMS requires you to understand the terminology used for the different MSC systems:

- The *originating system (local)* is the system from which the LU 6.2 program enters the IMS transaction.
- The *remote system* is the system in which the remote transaction executes.
- The *intermediate system* is the IMS that routes messages between the local and remote systems.

At any time, any of these three systems can receive LU 6.2 transactions.

---

## Recovering APPC Transactions in an MSC Environment

You can determine the recoverability of APPC messages in an MSC environment. Resource failures affect recovery. The recoverability of an IMS LU 6.2 transaction depends on whether the message is recoverable, irrecoverable, discardable, or nondiscardable, and when an error occurs.

To recover APPC transactions in an MSC environment, analyze the types of failures that can occur. How you handle the error depends on the following:

- The resource that fails: Was it an LU 6.2 session failure, an IMS failure, an application program failure, or an MSC link failure?
- Transaction mode: Was it recoverable or irrecoverable?
- Transaction type: Was it local or remote?
- LU 6.2 conversation mode: Was it asynchronous or synchronous?

You are in control of recovery by the way you define the transaction. To better understand the impact of your choices, read the following topics:

- “Recoverable versus Nonrecoverable Transactions”
- “Local APPC Transaction Discardability versus Nondiscardability” on page 421
- “OTMA Transaction Discardability versus Nondiscardability” on page 421
- “Transaction Processing Point of Failure” on page 421
- “Recoverability Flows of LU 6.2 Transactions” on page 424

The information in the listed topics highlights pertinent facts, and then points you to other areas in the IMS library where the subjects are explained in greater depth.

### Recoverable versus Nonrecoverable Transactions

By coding the inquiry parameter on the TRANSACT macro, you tell IMS the recovery status of a transaction. Non-inquiry mode transactions are recoverable; inquiry-mode transactions are not recoverable unless the RECOVER parameter is

specified on the TRANSACT macro. Recoverable transactions are recovered across any IMS failure, shutdown, or restart unless a COLDSTART, COLDSYS, or COLDCOMM restart is performed.

You must define remote transactions with identical recoverability attributes on the local system where the LU 6.2 session originates and on the remote system where the transaction is processed by the application program. You do not need to define the transaction on any intermediate IMS.

Message switches (messages from one LTERM to another) are always recoverable.

**Related Reading:** For more information on transactions and recoverability, see “Recovery Considerations” on page 232.

### Local APPC Transaction Discardability versus Nondiscardability

The LU 6.2 protocol that you choose for sending a transaction to IMS and the transaction mode (recoverable or irrecoverable) you choose determine if a local APPC transaction is discardable or nondiscardable.

IMS discards a local APPC transaction when it is any of the following:

- A CPI Communications driven application program (without SYNCLVL=SYNCPT specified)
- It is defined as inquiry-only and nonrecoverable
- It is the result of synchronous input from the LU 6.2 application program
- It uses the APPC Sync\_Level option NONE

Otherwise, the transaction is nondiscardable. IMS recovers nondiscardable transactions whenever possible; it never recovers discardable transactions.

### OTMA Transaction Discardability versus Nondiscardability

IMS discards a local OTMA transaction if it was submitted with a Send-then-Commit synchronization flag (Commit mode 1).

IMS recovers an OTMA transaction if it was submitted with a Commit-then-Send synchronization flag (Commit mode 0).

**Related Reading:** For more information on OTMA, see *IMS Version 9: Open Transaction Manager Access Guide and Reference*.

### Transaction Processing Point of Failure

The point of failure in the processing of a transaction also affects its recoverability. For example, when a local or remote transaction processes and reaches a commit point (sync point), IMS recovers the output response (from the log) even if you have defined the transaction as irrecoverable. Local APPC discardable transactions reach a commit point after IMS sends the output response message to the inputting APPC application program. In this situation, IMS has no output response message to recover or discard if a failure occurs after the commit point. If IMS has queued the transaction on an MSC link, IMS recovers the transaction across link failures.

A message can be either recoverable or irrecoverable, and either discardable or nondiscardable, according to the type of failure that might occur. The descriptions in this topic show you what happens to your transaction when the LU 6.2 session,

## Recovering APPC Transactions in an MSC Environment

MSC link, local IMS, intermediate IMS, remote IMS, or application program fail. This information assumes that you can recognize where a failure has occurred and what you need to do to recover.

### Recovering Transactions after an LU 6.2 Session Failure

If an LU 6.2 session fails while IMS is receiving an input message, IMS discards the message. If IMS receives the complete message, processing depends on whether the conversation is:

- CPI-C or not CPI-C
- Synchronous or asynchronous
- Local or remote

**CPI-C Transaction:** If an LU 6.2 session fails while processing a CPI-C transaction, the application program can choose to end the conversation or to continue processing. IMS TM is not involved, and places no restrictions on the choice of committing or backing out updates. The application program makes the decision. Because IMS TM does not know about the session failure, it takes no action. The normal processing rules for commit and backout apply. IMS does not recover the LU 6.2 conversation.

#### Related Reading:

- For information on designing your CPI-C LU 6.2 application program, see *IMS Version 9: Application Programming: Design Guide*.
- For information on CPI-C recovery and backout, see Chapter 19, “CPI Communications,” on page 395.

**Not a CPI-C Transaction:** If an LU 6.2 session fails while a local IMS is sending transaction output that is not CPI-C to the LU 6.2 program, and the conversation is synchronous, IMS calls the Message Control/Error exit routine to determine whether to abort and back out, or to continue processing. The default action is to stop the transaction and discard the output message (this is the mode of operation for all protected conversations; that is, conversations allocated using SYNCLVL=SYNCPT). If the conversation is asynchronous, IMS does not call the Message Control/Error exit routine, but queues the output on the message queue to the TP name of DFSASYNC.

**Related Reading:** For information on coding the Message Control/Error exit routine, see *IMS Version 9: Customization Guide*.

**Remote APPC Transaction:** If an LU 6.2 session fails while processing a remote APPC transaction, IMS recovers the output message if it has been enqueued on the local system’s MSC link. If the transaction has not at least reached the point of being enqueued on the MSC link, IMS discards it. IMS discards the transaction regardless of the recoverability mode and regardless of whether the LU 6.2 conversation is synchronous or asynchronous. IMS does not call the Message Control/Error exit routine:

- If the transaction is asynchronous, when the output from a remote transaction for a failed LU 6.2 session returns from the remote system to the originating system, IMS sends the response asynchronously to the LU 6.2 application program by using the DFSASYNC TP name.
- If the transaction is synchronous, when the output from a remote transaction for a failed LU 6.2 session returns from the remote system to the originating system, IMS calls the Message Control/Error exit routine to either discard or re-route the transaction output. The default action is to discard the output.

## Recovering APPC Transactions in an MSC Environment

**Related Reading:** For information on using DFSASYNC in your application program, see *IMS Version 9: Application Programming: Design Guide*.

### Recovering Transactions after an MSC Link Failure

When an MSC link failure occurs, IMS always recovers all messages, including IMS transactions and responses that are enqueued, about to be enqueued, or being sent across an MSC link. This recoverability is guaranteed, regardless of whether the message is en route to a local, intermediate, or remote MSC system. The recoverability is not affected by the transaction mode (recoverable or irrecoverable) or the discardable or nondiscardable characteristics of the LU 6.2 protocol used to send the transaction to the local IMS.

Link failures can delay messages from other IMSs and cause the synchronous LU 6.2 conversation to wait longer than expected for the response.

**Related Reading:** For information on restarting a logical link, see “Restarting a Logical Link” on page 229.

### Recovering Transactions after a Local IMS Failure

IMS discards local APPC transactions across a local IMS failure if they meet the discardability criteria listed in “Local APPC Transaction Discardability versus Nondiscardability” on page 421. Otherwise, IMS does not discard local APPC transactions, because they are nondiscardable.

If you define your remote APPC transactions as inquiry-type transactions and do not specify RECOVER on the TRANSACT macro definition in the local IMS, IMS does not recover them after a local IMS failure. Otherwise, IMS recovers all recoverable, nonconversational transactions.

After the local IMS sends the transaction message to an intermediate or remote IMS, a local IMS failure has no affect on your transaction’s recoverability. The transaction continues to its destination and is processed. When the remote IMS sends the transaction response to the originating IMS after the failure, IMS sends the response to its destination asynchronously through the DFSASYNC TP name. The LU 6.2 application programmer needs to plan for this situation.

**Related Reading:** For information on using DFSASYNC in your application program, see *IMS Version 9: Application Programming: Design Guide*.

### Recovering Transactions after a Remote IMS Failure

When a remote IMS failure occurs, based on the recoverability attributes of an APPC transaction in a remote IMS, IMS recovers the transaction if it is queued for processing or is being processed in the remote IMS. Recoverable transactions are recovered; irrecoverable transactions are not. After the transaction reaches a commit point, IMS recovers the output response message regardless of the recovery attributes of the transaction. The discardable and nondiscardable characteristics of the APPC conversation in the originating IMS have no bearing on the transaction’s recoverability in the remote IMS across a remote IMS failure.

IMS recovers transactions that are en route to the remote IMS (meaning the transaction message is still en route in the local or intermediate IMS) when the remote IMS fails, regardless of the transaction’s recoverability characteristics. After the failure, the remote IMS receives and processes the transactions that were en route at the time of the failure.

### Recovering Transactions after an Intermediate IMS Failure

IMS always recovers all messages en route to or from an intermediate IMS that are queued in the intermediate IMS regardless of the recoverability characteristics of the transaction or message. If the intermediate IMS restarts with either a COLDSTART, COLDCOMM, or COLDSYS, the messages are lost.

### Recovering Transactions after an Application Program Failure

Transactions sent to IMS from LU 6.2 application programs are processed in the same way as non-LU 6.2 initiated transactions during application program failures. If an application program fails before reaching a commit point while processing a local or remote transaction from an LU 6.2 device, IMS backs out all messages except those that were inserted to an alternate express PCB and committed with a PURG call. If the failure occurs after the transaction reaches a commit point, IMS recovers everything. If the failing application program's input message was received from another application program (program-to-program switch), this prior application program's processing is still committed (as is true for non-LU 6.2 application programs).

## Recoverability Flows of LU 6.2 Transactions

This topic contains four lists that show synchronous and asynchronous transaction flows, and shows when the transactions are recoverable, irrecoverable, discardable, or nondiscardable.

The following list shows the flow of a transaction sent from an LU 6.2 synchronous conversation to a local IMS.

1. LU 6.2 program: ALLOC LU=*IMS LU name*
2. LU 6.2 program: SEND to local IMS
3. LU 6.2 program: RECEIVE\_AND\_WAIT
4. Local IMS receives the transaction
5. Transaction is enqueued
6. Transaction executes (if application fails before reaching commit point, message is discarded)
7. Message inserted to I/O PCB
8. Local IMS sends output (Message Control/Error exit routine receives control if LU 6.2 session fails here)
9. Commit point
10. LU 6.2 program: DEALLOCATE

**Note:** The above flow does not guarantee resource integrity between a client and IMS. Such integrity requires the use of synclevel syncpoint and two-phase commit protocols. Specifically, IMS writes the X'3730' commit crossover record before sending the deallocate flow to the APPC client. An IMS failure between writing this record and the deallocate flow will cause IMS resources to be committed during emergency restart even though the client never received the deallocate. This record is not check-written to the WADS so it is also possible for the client to receive the deallocate flow although the IMS commit crossover record was never hardened and will not be processed by IMS restart. In this case, IMS will backout the UOR even though the client received the deallocate and might have committed its changes. Using synclevel=syncpoint and two phase commit flows is necessary if update consistency between IMS and the APPC client is required.

## Recovering APPC Transactions in an MSC Environment

The following list shows the flow of a transaction sent from an LU 6.2 asynchronous conversation to a local IMS:

1. LU 6.2 program: ALLOC LU=*IMS LU name*
2. LU 6.2 program: SEND to local IMS
3. LU 6.2 program: DEALLOCATE
4. Local IMS receives the transaction
5. Transaction is enqueued
6. Transaction executes (if application fails before reaching commit point, message is discarded)
7. Message inserted to I/O PCB
8. Commit point
9. Local IMS: ALLOCATE with TPN=DFSASYNC
10. Local IMS sends output
11. Local IMS: DEALLOCATE

The following list shows the flow of a transaction sent from an LU 6.2 synchronous conversation to a remote IMS:

1. LU 6.2 program: ALLOC LU=*IMS LU name*
2. LU 6.2 program: SEND to local IMS
3. LU 6.2 program: RECEIVE\_AND\_WAIT
4. Local IMS receives the transaction
5. Transaction is enqueued on remote queue and MSC link (message is recoverable across MSC link failure after enqueue on MSC link)
6. Local IMS sends message across MSC link to remote IMS
7. Remote IMS receives the transaction
8. Transaction executes
9. Output message inserted to I/O PCB
10. Remote IMS enqueues output message to MSC link (message is recoverable across MSC link failure after enqueue on MSC link)
11. Commit point
12. Remote IMS sends output message across MSC link to local IMS
13. Local IMS receives output message
14. Local IMS enqueues output message for LU 6.2 program
15. Local IMS sends output message to LU 6.2 program (Message Control/Error exit routine receives control if LU 6.2 session fails here)
16. LU 6.2 program: DEALLOCATE

The following list shows the flow of a transaction sent from an LU 6.2 asynchronous transaction to a remote IMS:

1. LU 6.2 program: ALLOC LU=*IMS LU name*
2. LU 6.2 program: SEND to local IMS
3. LU 6.2 program: DEALLOCATE
4. Local IMS receives the transaction
5. Transaction is enqueued on remote queue and MSC link (message is recoverable across MSC link failure after enqueue on MSC link)
6. Local IMS sends message across MSC link to remote IMS
7. Remote IMS receives the transaction

## Recovering APPC Transactions in an MSC Environment

8. Remote IMS enqueues the transaction
9. Transaction executes
10. Output message inserted to I/O PCB
11. Remote IMS enqueues output message to MSC link (message is recoverable across MSC link failure after enqueue on MSC link)
12. Commit point
13. Remote IMS sends output message across MSC link to local IMS
14. Local IMS receives output message
15. Local IMS enqueues output message for LU 6.2 program
16. Local IMS: ALLOCATE with TPN=DFSASYNCR
17. Local IMS sends output message to LU 6.2 program (Message Control/Error exit routine receives control if LU 6.2 session fails here)
18. Local IMS: DEALLOCATE

---

## Planning for XRF and APPC

All LU 6.2 conversation messages that are sent to a failing IMS are broken at the time of an XRF takeover. New conversations must be allocated on the new active IMS after takeover processing completes. XRF support for LU 6.2 application programs is Class 3 service.

The application program uses the USERVAR parameter as the LU name parameter on the ALLOCATE verb. This allows the same LU name to allocate the conversation on the new active IMS. This is the same concept as the LU usage for non-LU 6.2 IMS terminals, but a different USERVAR name is used. At takeover time, the alternate IMS issues a VTAM MODIFY USERVAR command to redirect the USERVAR from the failed active IMS to the alternate IMS. Also, a VTAM VARY TERM command is issued against the failed active IMS to terminate any conversations held during takeover. Then VTAM propagates the USERVAR changes to other VTAMs as needed without the use of NCCF CLISTS.

Any APPC transactions that are enqueued to a remote IMS are handled by the MSC protocols. After takeover in the local IMS, the queued irrecoverable messages are lost. If the same message is queued to a remote IMS, it is recovered when the local IMS takes over. Processing continues and the reply is sent to the active IMS.

VTAM, z/OS, Tivoli NetView for z/OS, and any other product requirements should be carefully reviewed. APPC/IMS requires correct operation of these other products.

---

## Transaction Retry Characteristics

IMS retries certain abend conditions. Some examples of these conditions that are retried are:

- Deadlock
- Lock reject
- Fast Path retry conditions

These retry conditions still apply to standard DL/I application programs even if they receive their messages from an LU 6.2 application program. If an abend that can be retried occurs, IMS issues an APPC ATBEXAI call to APPC/MVS to determine if any established conversations exist. If a conversation has been allocated, the abend is not retried and the application program is terminated.



If any CPI Communications resource is being used by the application program, the abend condition cannot be retried. Thus, CPI Communications driven application programs and modified IMS application programs that have allocated an LU 6.2 conversation before the abend occurred can never be retried. This prohibition on retry is necessary, because IMS cannot control the state of CPI Communications resources. IMS supports the DL/I INIT STATUS GROUPB call for CPI Communications driven application programs, but not for modified IMS application programs that have allocated an LU 6.2 conversation before the deadlock is detected.

---

## Qualifying Network LU Names

You can use the same name for LUs on different systems by adding the network identifier. This eliminates the need to have unique names for every LU on every system in your complex. You can use the network-qualified LU name as the name of the partner LU to allocate remote LU 6.2 conversations and sessions.

A network-qualified LU name consists of a one- to eight-character network identifier of the originating system, followed by a period and the LU name. A network-qualified LU name must be enclosed in single quotes for commands.

**Example:** /DISPLAY LUNAME'NETID1.LUAPPC2' OUTPUT

Use a network-qualified LU name when transmitting data to a remote destination. If no network identifier is present, IMS allows z/OS to determine the destination.

The parameter ALL for either the network identifier or the LU name cannot be substituted in a network-qualified LU name in commands.

**Example:** /DISPLAY LUNAME'NETID1.ALL' OUTPUT

The LU name in the LU 6.2 descriptor can be network qualified. The network-qualified LU name is optional on commands that support the LUNAME keyword.

APPC/MVS uses the name of LU 6.2 network-qualified LUs to allocate conversations. APPC/MVS strips off the network ID and passes the 8-byte LU name to VTAM. Without APPC/MVS support for network-qualified names, the LU name must be unique for the different networks.

The ALL parameter for either the network identifier or the LU name cannot be substituted in a network-qualified LU name in a command.

The LU name in the LU 6.2 descriptor can be network qualified.

**Related Reading:** For information on using network-qualified names in commands, see *IMS Version 9: Command Reference*.

---

## DFSAPPC System Service

DFSAPPC is an IMS system service for exchanging messages between LU 6.2 application programs (LU 6.2 to LU 6.2), and between LU 6.2 application programs and IMS-managed LTERMs. Message delivery is asynchronous; messages are held on the IMS message queue until they are delivered.

LU 6.2 application program can use DFSAPPC to send messages to IMS-managed LTERMs. Use the LTERM option of the DFSAPPC service to select this capability.

## Message Switching

Message switching is part of the implicit APPC interface and allows IMS terminals and LU 6.2 application programs to exchange messages. Messages routed to an LU 6.2 application program initiate LU 6.2 application programs.

When using DFSAPPC, the remote device can choose to route a message using either the LTERM or LU 6.2 TPN option. Messages sent with the LTERM option are directed to IMS-managed local or remote LTERMs.<sup>32</sup> Messages sent without the LTERM option are sent to the specified LU 6.2 application program.

The message format for DFSAPPC is shown in Figure 62.

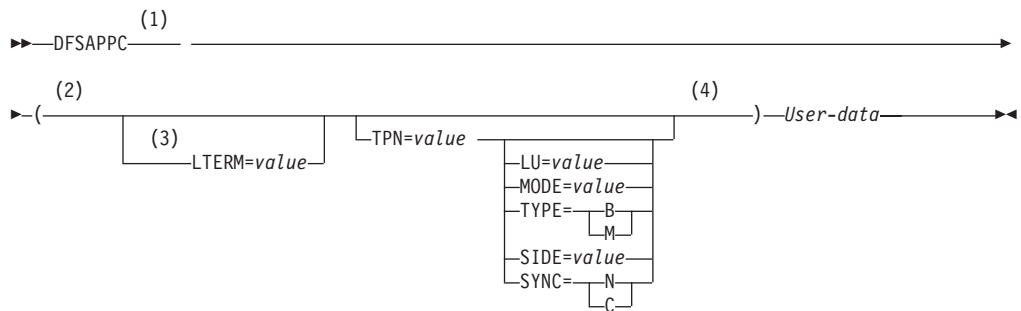

**Notes:**

- 1 A mandatory blank is required between DFSAPPC and the options.
- 2 Use blanks anywhere within the DFSAPPC options except within keywords or values. Use commas as delimiters between keyword-parameter sets along with or in place of blanks. However, because the TP name character set allows commas, at least one blank must be used to terminate the TPN value.
- 3 You can specify either the LTERM= or the TPN= option, but not both. Only use the other keyword options when you specify the TPN= option.
- 4 Use the IMS default values for the DFSAPPC options to establish an LU 6.2 conversation with a partner program when the values are not provided by another source. If the DFSAPPC service is coded without specifying any options, use IMS default LU 6.2 conversation characteristics.

Figure 62. DFSAPPC Message Format

The DFSAPPC option keywords are defined as follows in order of occurrence (except for the keywords following TPN=, which are listed alphabetically):

**LTERM=**

The 1- to 8-character LTERM option is the name of an IMS LTERM. Messages sent with the LTERM option are directed to an IMS-managed local or remote LTERM. If the LTERM is associated with the LU 6.2 descriptor, it is treated as if an LU 6.2 application program has been explicitly selected. LTERM names can contain uppercase alphabetic, numeric, and national characters ('@', '\$', '#'). When LTERM is specified, other keywords cannot be specified.

32. If the LTERM is associated with an LU 6.2 destination, the message is sent as if an LU 6.2 application program had been explicitly selected.

**TPN=**

The 1- to 64-character TPN option is the partner's transaction program name used with the logical unit name to establish an LU 6.2 conversation with a partner program. Because the TP name character set allows commas, at least one blank must be used to terminate the TPN value.

TP names can contain any character from the 00640 character set except a blank. The 00640 character set, documented in the *Common Programming Interface Communications Specification* includes uppercase and lowercase letters A through Z, numerals 0-9, and 20 special characters.

When the TPN and SIDE options are specified, the TPN name overrides the TP name contained in the side information entry.

Although DFSAPPC allows the use of the 00640 character set, IMS commands do not use this character set. IMS commands can only operate on TPNs that use uppercase alphabetic, numeric, and national characters ('@', '\$', '#'). IMS commands cannot operate on extended TPNs.

**LU=**

The 1- to 17-character LU option is the partner's logical unit name used with the transaction program name (TPN) to establish an LU 6.2 conversation with a partner program.

LU names can contain any character from the APPC/MVS Type A character set. LU names can contain uppercase alphabetic, numeric, and national characters ('@', '\$', '#'), and must begin with an alphabetic or national character. You can also use a 17-byte network-qualified LU name in the LU field.

When the LU and SIDE options are specified, the LU name overrides the LU name contained in the side information entry.

**Related Reading:** For more information on Type A character sets, see *MVS Programming: Writing Transaction Programs for APPC/MVS*.

**MODE=**

The 1- to 8-character MODE option is the partner's mode name used with the logical unit name and transaction program name to establish an LU 6.2 conversation with a partner program.

MODE names can contain any character from the APPC/MVS Type A character set. MODE names can contain uppercase alphabetic, numeric, and national characters ('@', '\$', '#'), and must begin with an alphabetic or national character.

When the MODE= and SIDE options are specified, the MODE name overrides the mode name contained in the side information entry.

**Related Reading:** For more information on Type A character sets, see *MVS Programming: Writing Transaction Programs for APPC/MVS*.

**SIDE=**

The 1- to 8-character SIDE option is the side information entry name used to establish an LU 6.2 conversation with a partner program.

SIDE names can contain any character from the 01134 character set. The 01134 character set, documented in the *Common Programming Interface Communications Specification* includes uppercase alphabetic characters A through Z and numeric characters 0-9.

When the SIDE option is specified, the LU, TPN, and MODE options can also be specified to override the values in the side information entry.

## DFSAPPC System Service

### SYNC=

The SYNC option allows the application to override the LU 6.2 conversation sync level default provided by IMS.

**SYNC=N** Sync\_Level is NONE.

**SYNC=C** Sync\_Level is CONFIRM.

### TYPE=

The TYPE option allows the application to override the LU 6.2 conversation type default provided by IMS.

**TYPE=B** Conversation type is BASIC.

**TYPE=M** Conversation type is MAPPED.

If an error is found while processing the options list, error message DFS1957 DFSAPPC ERROR is sent to the terminal.

**Related Reading:** For more information on error message DFS1957, see *IMS Version 9: Messages and Codes, Volume 2*.

## Asynchronous Output Delivery

When creating a message destined for an LU 6.2 application program, IMS establishes conversation characteristics. These characteristics are extracted from the:

- LU 6.2 descriptor
- DL/I Change call option list
- DFSAPPC message switch options

If IMS cannot extract a particular conversation characteristic from this list, IMS uses the defaults shown in Table 65. If a side table name is extracted, the default mode name is not used. IMS assumes that side table entries contain a mode table entry name. If an /ALLOCATE command for a particular LUNAME - TPNAME destination specifies a mode table entry name, that entry name overrides the mode table name specified for the message.

Table 65. APPC/IMS Default Conversation Characteristics

Characteristics	Default Value
Conversation_Type	Mapped
Deallocate_Type	Deallocate_Sync_Level
Error_Direction	Receive_Error
Fill	Fill_LL
Log_Data	Null
Log_Data_Length	0
Mode_Name	'DFSMODE' <sup>1</sup>
Mode_Name_Length	7
Partner_LU_Name	'DFSLU'
Partner_LU_Name_Length	5
Prepare_to_receive_type	Prep_To_Receive_Sync_Level
Receive_type	Receive_and_Wait
Return_Control	When_Session_Allocated
Send_Type	Buffer_Data

Table 65. APPC/IMS Default Conversation Characteristics (continued)

Characteristics	Default Value
Sync_Level	Confirm
TP_Name	'DFSASYNC'
TP_Name_Length	8

**Note:**

<sup>1</sup>IMS uses the same mode name provided by the inputting LU 6.2 partner to allocate the outbound conversation. That is, whatever mode name the inputting conversation uses, IMS also uses it for outbound allocates.

IMS uses this information to initiate a conversation with the LU 6.2 application program associated with the alternate PCB. Certain fields, such as LU name, are application specific. Default values are provided but can be overridden by parameters associated with the message. A default value is used by IMS only if no value is provided by any other source. The application program can modify the default conversation characteristics using an expanded interface to the DL/I CHNG call.

---

## APPC Transaction Security

The security options for APPC/IMS and LU 6.2 application programs are quite extensive. The partner systems can range from a single-user terminal, such as a PS/2<sup>®</sup>, to a multi-user system, such as VM/ESA<sup>®</sup>. All systems can have their own complex security environment. Security for IMS can be simple or complex.

Every transaction program name (TPN) must pass a security check before it is executed. The user ID that initiates the transaction is identified on the LU 6.2 format header (FMH5). If no user ID exists because you specify SECURITY=NONE, you can only access resources that are not defined with UACC (NONE). Any TPNs that are accessible in all circumstances should not be defined with UACC (NONE). The TPN security definition is required.

z/OS security consists of two parts. First, z/OS authenticates the transaction user. The LU 6.2 transaction contains security information. The FMH5 contains the user ID, a “profile” name, which is used as the group name, and security options. You supply both the user ID and password. The user ID is defined to RACF, and the password must be valid for the user ID.

If Already\_Verified is specified in the FMH5, the sending system verifies the user ID. This user ID must be defined to RACF on the receiving z/OS system. No password is needed in this case.

If SECURITY=NONE is specified, z/OS does no checking. Instead, z/OS builds a special security profile that corresponds to SECURITY=NONE. This allows access to z/OS and APPC/IMS resources that have UACC specified at any level other than NONE. Resources with UACC (NONE) or without a UACC specified cannot be accessed.

After the user ID is established, z/OS verifies that the user ID can execute the specific transaction. z/OS verifies that the user ID's access profile has ACCESS (EXECUTE) for the entity *dbtoken.x.tpname* in the CLASS (APPCTP). The value of

## APPC Transaction Security

*dbtoken* is the *dbtoken* value specified in the *TP\_Profile* data set. Based on the *APPCTPxx* parameter specified for this LU, the value of *x* is either the *user ID*, *group* or *SYS1*.

If either of these security checks fails, z/OS rejects the transaction, and IMS is not informed of it. z/OS can also check:

- Session-level security (RACF resource class APPCLU)
- Port of entry (RACF resource class APPCPORT)
- Local application (RACF resource class APPL)

The IMS administrator should verify that these security checks are successful.

**Related Reading:** For more information on coding the RACF resource classes, see *z/OS V1R4.0 MVS Planning: APPC Management*.

The security check in IMS is based on the IMS transaction code or executed command name. If the TPN is DFSAPPC, no additional security check occurs. If RACF is used on your system, z/OS rejects the transaction if RACF is not active. The IMS command name or transaction code associated with the TPN is used in the RACF resource class associated with this IMS ('C' or 'T'). RACF checks IMS commands and transactions for all other IMS terminal types in the same way.

If the RACF check is successful, the Transaction Authorization exit routine (DFSCTRN0) is called for transactions, and DFSCCMD0 is called for command authorization. However, the following rules apply to RACF:

- For commands, default security only applies if RACF is not used.
- For remote transactions, RACF is optional.

Otherwise, the exit routines make the security decision.

The intended environment executes APPC/IMS with RACF security active. It is possible to run with RACF not active in the APPC/IMS system, but it is not possible to run with RACF not active in the z/OS system. In this sense, RACF is mandatory for LU 6.2.

The complexity of the security environment is derived partly from the many resources involved (VTAM, z/OS, and IMS) and the granularity of protection that is possible. The security definitions must be closely coordinated for successful operation of the application system.

**Related Reading:** For more information on using IMS Security, see *IMS Version 9: Administration Guide: System*.

---

## Part 7. SLU P and Finance Communication

### Chapter 21. Overview of SLU P and Finance

<b>Communication</b> . . . . .	435
The IMS-SLU P Network . . . . .	436
System Configuration . . . . .	436
SLU P and Finance Workstations . . . . .	436
System Controller Application Program . . . . .	437
Writing the Controller Application Program with MFS and XRF . . . . .	437
Writing the Controller Application Program for MFS . . . . .	437
Writing the Controller Application Program for XRF Systems . . . . .	438
Converting Controller Application Programs from Finance to SLU P . . . . .	438
VTAM Facilities Used . . . . .	439
VTAM Commands and Indicators . . . . .	439
Request-Recovery Command . . . . .	440
Change-Direction Indicator . . . . .	441
Establishing Connection and Specifying Logon Modes . . . . .	441
Establishing Connection with the XRF Complex Bracket and Send/Receive Management . . . . .	442 443

### Chapter 22. IMS Facilities Used for SLU P and Finance

<b>Component Definition</b> . . . . .	445
LTERM Naming . . . . .	445
Output Component Selection . . . . .	446
Input Component Determination . . . . .	446
Terminal-Response Mode . . . . .	447
Defining a Workstation for Terminal-Response Mode . . . . .	448
Output Messages Sent While in a Between-Brackets State . . . . .	449
Designing for Output Messages Sent While in Between-Brackets State . . . . .	450
IMS Message Format Service . . . . .	450
Designing MFS for the Workstation Environment . . . . .	450 450
MID/MOD Chaining . . . . .	450
MFS Output Formatting for the SLU P System MFS Message Recovery . . . . .	451 451
MFS Control Functions (Finance) . . . . .	451
MFS Control Functions (SLU P) . . . . .	452
MFS Paging and BID Options . . . . .	452
Display Screen Protection for Finance Stations . . . . .	453
Extended Output Component Protection (SLU P) Input and Output Editing Options (SLU P) . . . . .	453 455
Use of Responses or Brackets to Acknowledge Recoverable Input . . . . .	456 456
Message Recovery . . . . .	457
Message Resynchronization . . . . .	458
Finance and SLU P in an XRF Complex . . . . .	459
Fast Path Messages with Finance and SLU P . . . . .	459
Fast Path Output Messages (Finance) . . . . .	459
Fast Path Output Messages (SLU P) . . . . .	460

Fast Path Message Resynchronization . . . . .	461
---	-----

### Chapter 23. Network Operation for SLU P and Finance

<b>Starting an IMS Network</b> . . . . .	463
<b>Making IMS Ready</b> . . . . .	463
<b>Session Initiation (Starting Workstations)</b> . . . . .	464
Session-Initiation Transmission Sequence . . . . .	464
Controller Application Program Involvement in Message Resynchronization . . . . .	465 465
Design Considerations . . . . .	465
Sequence Number Management . . . . .	466
Set-and-Test-Sequence-Numbers (STSN) . . . . .	466
Suspending Output from IMS . . . . .	470
Session Termination . . . . .	470
Orderly Termination . . . . .	471
Immediate Termination . . . . .	471
Shutting Down an IMS Network . . . . .	472
SLU P Messages . . . . .	472
Send/Receive and Bracket Protocol . . . . .	473

### Chapter 24. SLU P Message Protocols

<b>General Format of Input Function Management Headers (Finance)</b> . . . . .	475 475
<b>Input Message Descriptor Byte (Finance)</b> . . . . .	476
<b>General Format of Input Function Management Headers (SLU P)</b> . . . . .	476 476
Input Message Descriptor Bytes (SLU P) . . . . .	477
Input Component Identification (SLU P) . . . . .	478
Input Bracketing Protocol . . . . .	478
Activating MFS Input Formatting for Finance Workstations . . . . .	478 478
Output Messages . . . . .	479
MFS Distributed Presentation Management Output (SLU P) . . . . .	481 481
<b>General Format of Output Function Management Headers (Finance)</b> . . . . .	482 482
Output Message Descriptor Byte (Finance) . . . . .	482
Output Component ID Byte (Finance) . . . . .	482
MFS Data Bytes (Finance) . . . . .	482
<b>General Format of Output Function Management Headers (SLU P)</b> . . . . .	483 483
Output Message Descriptor Bytes (SLU P) . . . . .	483
MFS Data Bytes (SLU P) . . . . .	484
Output Bracketing Protocol . . . . .	485
Activating MFS Output Formatting . . . . .	485
Response Requests (Finance) . . . . .	486
Response Requests (SLU P) . . . . .	486
Input Response Requirements . . . . .	486
Output Response Requirements . . . . .	487
IMS Transaction Types . . . . .	488
Recoverable-Inquiry Transactions . . . . .	488
Irrecoverable-Inquiry Transactions . . . . .	489
Verifying IMS Receipt of Irrecoverable Messages IMS Message Switches . . . . .	489 489
IMS Commands . . . . .	490

## Administering SLU P and Finance Communication

VTAM Commands and Indicators . . . . .	490
MFS Control Requests . . . . .	490
Error Handling . . . . .	490
IMS-Detected Errors . . . . .	490
Controller or Station-Detected Errors . . . . .	491
VTAM Logical Unit Status (LUSTATUS) Command . . . . .	493
VTAM Ready-to-Receive (RTR) Command. . . . .	493
VTAM CANCEL Command . . . . .	494
VTAM Request-Recovery Command. . . . .	494



---

## Chapter 21. Overview of SLU P and Finance Communication

This chapter presents an administrative overview of SLU P and Finance Communication Systems, and explains how IMS implements this architecture.

### In this Chapter:

- “The IMS-SLU P Network” on page 436
- “System Configuration” on page 436
- “SLU P and Finance Workstations” on page 436
- “System Controller Application Program” on page 437
- “Writing the Controller Application Program with MFS and XRF” on page 437
- “Converting Controller Application Programs from Finance to SLU P” on page 438
- “VTAM Facilities Used” on page 439
- “VTAM Commands and Indicators” on page 439
- “Establishing Connection and Specifying Logon Modes” on page 441
- “Establishing Connection with the XRF Complex” on page 442
- “Bracket and Send/Receive Management” on page 443

User-written application programs for IBM Finance Communication Systems can be defined to operate in two different ways with IMS—as an IBM 3600/4700 Finance Communication Controller or as a secondary logical unit type P (SLU P). These systems are described as `UNITYPE=FINANCE` and `UNITYPE=SLUTYPEP`, respectively, on the `TYPE` macro statement.

### Definitions:

- This chapter uses the term *SLU P* when describing support that is applicable to both system types.
- This chapter uses the terms *Finance* and *SLUTYPEP* when it is necessary to distinguish between the systems.

A major difference between SLU P and Finance systems is the level of MFS support available to workstations in the programmable control unit.

- Finance—Workstations can be identified as displays, printers, passbook printers, and ATMs (automated teller machines), such as the 4730 systems. MFS can provide detailed support for display paging, printer page formatting, and ATMs.
- SLU P—Each LU in the controller has a program name and its unique device characteristics are unknown to IMS. The programmable controller is responsible for device control and formatting. The MFS administrator and the program administrator for the remote controller need to establish data field structures for exchanged messages. MFS accepts the input structure and rearranges it as required for the IMS application program. At output, MFS accepts application program-provided data and converts it to the correct format for transmission to the controller. This MFS facility is called distributed presentation management (DPM).

**Related Reading:** For more information on ETO and SLU P and Finance systems, see “ETO and 3600/Finance and SLU P” on page 192.

### The IMS-SLU P Network

The three major elements of an IMS-SLU P network are:

- The controller and the terminals executing the remote program
- The communication link
- The central processor executing the host IMS system

Each element includes programming to perform a part of the total data processing performed by the system. IMS resides in the host processor and communicates with an application program in the SLU P system's controller through the communication link. The controller's application program monitors the terminals attached to the controller.

IMS supports 4700 terminals attached to an IBM 4701/4702 Finance Communication Controller. IMS supports the IBM 4730 Personal Banking Machine, both directly attached to a 37x5 as a SLU P and attached to a 4701/4702 as part of the SLU P system.

**Related Reading:** For a list of 4700 terminals, see *IBM 4700 Finance Communication System: System Summary*.

IMS also supports 3600 terminals attached to either an IBM 3602 or 4701/4702 as part of a Finance system. (IMS does not distinguish between 3600- and 4700-series terminals.)

Examples of other IBM products that connect to IMS with the SLU P protocols are the Series/1, the IBM 3650, and the IBM 8100.

Each of these terminals, or workstations, can be defined to IMS as a component of the appropriate SLU P system using the COMPT or ICOMPT keyword on the TERMINAL macro statement.

---

### System Configuration

Before configuring a SLU P system, you must identify the financial operations that are required of the planned system. After you have done this, you can define to IMS the configuration of the logical units and components. The SLU P system is regarded by IMS as a subsystem and consists of one or more logical units.

**Definition:** When configuring the system, you can define one or more *logical units*. These logical units<sup>33</sup> can consist of devices, storage, and application programs.

---

### SLU P and Finance Workstations

A workstation can consist of one or more terminals. Each workstation performs a specific type of financial operation, such as teller operation (deposits and withdrawals), report printing, or cash dispensing. The workstation, as defined to IMS, does not need to reflect the actual devices attached to it at the 4701/4702, but the workstation must reflect IMS's view of the workstation.

A sample configuration is available from the IMS library (IMS.ADFSMAC; member name=DFSCP360).

---

33. These logical units are referred to as *logical workstations* in Finance Communication System publications.

---

## System Controller Application Program

The operation of a workstation is controlled by a user-written application program that resides in the SLU P system's controller. The application program can be designed to control one or more workstations and needs only to perform the functions required by its workstations. The functions available to the application program include:

- Reading and writing to the terminals associated with the workstation
- Editing and verifying the data received from the terminal
- Reading and writing to the controller diskette
- Reading and writing to the host processor
- Editing and verifying data received from the host processor
- Operating offline when the host processor or IMS is unavailable

---

## Writing the Controller Application Program with MFS and XRF

If your system uses MFS and XRF, this topic provides information that pertains to writing the controller application program.

### Writing the Controller Application Program for MFS

When writing the controller application program for a system that uses MFS, do each of the following:

- Do not specify the WL (warning line) option on the 4700 controller's TERMINAL macro instruction. Specifying the WL option can cause an unexpected Finance system data exception error to occur on an LWRITE instruction.
- Specify the PS (page size) option on the 4700 controller's TERMINAL macro only if EJECT is specified on the IMS MFS DEV statement. If PS is not specified, the EJECT from IMS results in a new line function. If the "end-of-page" condition occurs on a workstation, an unexpected Finance system data exception error can occur. An EJECT from IMS resets the line count, resulting in an "end-of-page" condition.

If the CFOLD option is specified on the 4700 controller's TERMINAL macro instruction, the formats defined for MFS should not cause spacing for the center fold on a passbook. The SLU P system performs this function automatically.

- Check to see if the IMS MFS DFLD statement specifies ATTR=YES. If it does, any attempt to print an underscore (X'6D') can result in either of the following:
  - A data check on a 3610/3612
    - Specify a print position for the EBCDIC value (X'6D') when the OUTRTBL statement specifies other than the 128-character set for the 3610/3612 device.
  - Printing of a blank on a 3618 device
    - Specify a print position for the EBCDIC value (X'6D') when the OUTRTBL statement specifies the 48-character set for a 3618 device.
- Check to see if the MFS DEV statement option of EJECT, BGNMXG, BGNPP, or ENDPP is used to send eject characters (X'0C') within one IMS output transmission (other than the last character). If so, an "intervention-required" condition occurs on the passbook printer after the eject. In this situation, your application program in the controller must be capable of issuing multiple LWRITE instructions to the passbook printer to print the IMS output transmission. Each LWRITE should include the data up to and including an eject character, or up to the end of the transmission.

## Writing the Controller Application Program with MFS and XRF

**Related Reading:** For more information on coding the controller's macros, see *IBM 4700 Finance Communication System: System Summary*.

### Writing the Controller Application Program for XRF Systems

If your SLU P system operates in an XRF complex, your controller application program must be able to handle messages lost during an XRF takeover. Many messages that are "in-flight" when the alternate system takes control are recovered with no action from the application program or terminal operator. In this case, the takeover is transparent.

When the takeover is not transparent, message DFS3861I is issued in one of the following combinations:

- Message DFS3861I only—If the output message is recoverable, this indoubt message is issued. If irrecoverable, this message is not issued. If you are receiving output from IMS, and the new active IMS system cannot determine if you received the message, IMS requests an exception response but is not receiving one from your program.
- A CANCEL command followed by message DFS3861I—multi-segment output is in progress (last-in-chain not yet sent). If the in-flight message is recoverable, you should receive the in-flight message again. If the in-flight message is irrecoverable, the next in-flight message (if one is on the queue) is issued.
- An exception response followed by message DFS3861I—your input message is lost. Resend your last input message.

---

## Converting Controller Application Programs from Finance to SLU P

All current functions available for logical units defined to IMS as Finance, except the SCAN/NOSCAN option and Finance MFS, have similar functions for logical units defined as SLU P. IMS does not scan output for the control character sequence when sending output to a secondary logical unit type P. Therefore, the implied option is NOSCAN. If an application program uses MFS, it must be converted to use the distributed presentation management (DPM) option, which divides responsibility for message formatting between MFS and a user program residing within the logical unit. With the use of the DPM option, physical terminal characteristics are not defined to MFS. MFS formats and presents data to the user program component of the SLUTYPEP. The user program must complete the formatting, if necessary, and present the data to a physical device.

To execute correctly when defined to IMS as SLU P, existing remote user-written programs that run in a Finance controller must be converted as follows:

- Any input message headers must be converted to SLU P message headers.
- Any input message indicating only begin-bracket must also indicate change-direction.
- If the TERMINAL macro SCAN option is specified, the Finance controller application program must be converted to detect and process the same options provided by the SCAN option.
- If the controller application program uses MFS, the remote application must be converted to use the device-independent MFS distributed presentation management option.
- When converting from Finance-specific MFS to DPM, the MFS format descriptions must be redefined and recompiled using the IMS MFS Language utility.

---

## VTAM Facilities Used

The physical transmission of data between IMS and a SLU P system is controlled by VTAM.

**Related Reading:** For more information on the communication facilities that govern data transmission between IMS (a VTAM application program) and the controller, see *Network Program Products General Information and Communications Server: SNA Programming*.

The VTAM facilities that IMS uses, particularly for a SLU P system, include:

- Connection, disconnection, and establishing logon mode
- Messages and responses
- Definite response 1 and definite response 2 <sup>34</sup>
- Sequencing and chaining
- Quiescing
- Facilities for ensuring orderly communication, including the use of brackets <sup>35</sup> and change-direction indicators <sup>36</sup>
- Sequence-number recovery
- Receiving input, sending messages
- Unconditional bracket termination
- Primary Error Recovery Procedure (ERP)

The ERP is terminated by an IMS output error message sent to the workstation.

**Related Reading:** For more information on IMS error handling, see “Error Handling” on page 490.

IMS also supports the class of service (COS) and session outage notification (SON) facilities.

**Related Reading:**

- For more information on the COS and SON facilities, see “Using SON/COS Support in IMS” on page 64.
- For more information on communications concepts and facilities, see *Systems Network Architecture Technical Overview* and *Systems Network Architecture Format and Protocol Reference: Architectural Logic*.

---

## VTAM Commands and Indicators

VTAM commands and indicators (communication control information) are necessary for data transmission between an IMS application program and another VTAM logical unit. Table 66 on page 440 shows which VTAM commands and indicators IMS sends to and receives from the SLU P controller. Results are unpredictable if any unsupported commands or indicators are used.

With the exception of the request-recovery command and the change-direction indicator, which are described following the table, the commands and indicators

---

34. All data transmitted between IMS and a workstation must request a definite response 1, definite response 2, definite response 1 and 2, or exception definite response 1 or 2. VTAM commands must request definite response 1.

35. In SNA protocol, a bracket is one or more chains of request units (RU) and the responses that are exchanged between two LU-to-LU half sessions that represent a transaction.

36. In VTAM, a change-direction indicator means that the sender has finished sending and is prepared to receive.

## VTAM Commands and Indicators

operate as described in *Network Program Products General Information*.

Table 66. VTAM Commands and Indicators Sent and Received by IMS

VTAM Command/Indicator	IMS Sends to Controller	IMS Receives from Controller
INDEPENDENT OF SESSION		
Initiate Session		X
Procedure Error	X	
Terminate Session		X
SESSION CONTROL		
Bind	X	
Clear	X	
Request-Recovery (RQR)		X
Set-and-Test-Sequence Numbers (STSN)	X	
Start Data Traffic (SDT)	X	
Unbind	X	
NORMAL (synchronous) FLOW		
Begin-Bracket (BB)	X	X
BID	X	
CANCEL	X	X
CHASE		X
End-Bracket (EB)	X	X
Logical Unit Status (LUS)		X
Quiesce Complete (QC)	X	
Ready-to-Receive (RTR)		X
Change Direction (CD)		X
EXPEDITED (asynchronous) FLOW		
Quiesce-at-end-of-chain (QEC)		X
Release Quiesce (RELQ)		X
Request-Shutdown (RSHUTD)		X
Shutdown (SHUTD)	X	
Shutdown Complete (SHUTC)		X
Signal		X

**Recommendation:** During a SLU P session, every input message must have either a change-direction (CD) or end-bracket (EB); otherwise, the session is terminated.

### Request-Recovery Command

Upon receipt of the VTAM Request-Recovery (RQR) command, IMS issues a CLEAR. The SLU P application programmer must exercise care when sending this command while a recoverable IMS output message is in progress. To send an RQR command to IMS, the application program must first respond to the output operation that is in progress. If the application program does not send the reply but instead sends only the RQR command, the controller automatically sends the outstanding DR2 reply at the LEXIT or next LREAD statement. If IMS receives the

RQR command before the DR2 reply, the CLEAR generated by IMS can cause the DR2 reply to be lost. The status of the current output message is then unpredictable.

**Related Reading:** For an important restriction, see “Message Resynchronization” on page 458.

## Change-Direction Indicator

IMS supports use of the change-direction indicator on the last chain element of an input message or a VTAM command. This allows device support to be more consistent with VTAM operation. The operation of IMS is not affected by the indicator.

---

## Establishing Connection and Specifying Logon Modes

When establishing connection using the VTAM OPNDST macro instruction, IMS specifies session parameters that define the rules that a logical unit must follow when communicating with IMS.

IMS examines either a user-supplied or a VTAM default set of session parameters, and overlays only those parameters on which IMS has dependencies. The remaining bytes are not changed. You can include user data with the BIND parameters.

**Related Reading:** For information on the BIND parameters for SLU P, see Appendix B, “Bind Parameters for SLU P and LU 6.1,” on page 503.

User data included within the BIND is used by IMS as input to the signon process and is similar in function to the IMS /SIGN command. This is required for ETO Finance terminals and SLU P terminals, but is optional for static terminals.

If you do not specify a mode name on the TERMINAL macro statement during IMS system definition or on the logon descriptor, you can supply a mode name using any of the following methods:

- On the VTAM network operator VARY command
- On the IMS OPNDST command
- On a request for system initialization by another logical unit

If you specify a mode name on the IMS TERMINAL macro statement or on the logon descriptor, it is used, unless you override it using the IMS /OPNDST command or the VTAM VARY command.

If you do not supply a mode name during IMS system definition using a logon descriptor, on an IMS command, or using CINIT, VTAM assumes a default mode name.

**Related Reading:** For more information on establishing logon mode tables and defining logon mode table entries, see *Communications Server: SNA Resource Definition Reference*.

You can override the use of the default logon mode table entry in one of two ways:

- At system definition, you can specify the logon mode entry on the TERMINAL macro using MODETBL=keyword.

## Establishing Connection and Specifying Logon Modes

**Related Reading:** For information on specifying the MODETBL keyword, see *IMS Version 9: Installation Volume 1: Installation Verification*.

- You can specify on the MODETBL keyword of the /OPNDST command that the logon mode table entry replace the table entry defined at system definition.

**Related Reading:** For information on specifying the /OPNDST command, see *IMS Version 9: Command Reference*.

IMS overrides the session parameters for function management, transmission services, and primary and secondary network protocol.

---

## Establishing Connection with the XRF Complex

To establish a session with IMS in an XRF complex, your logon request must include either the USERVAR name you defined in the USERVAR tables or the MNPS ACB name shared by both of the IMSs in the XRF complex. In the case of XRF with USERVAR, VTAM matches the USERVAR logon message to the IMS application that is currently active. For XRF with MNPS, VTAM links directly to the active IMS's MNPS ACB.

**Related Reading:** For information on defining USERVAR or the MNPS ACB to VTAM, see *IMS Version 9: Administration Guide: System*.

If you use XRF with USERVAR, SLU P terminal programs cannot use the APPLID name in the PLUNAME field of the BIND to reestablish a session with IMS. Instead, SLU P terminal programs must use the USERVAR in the user data field of the BIND. This restriction does not apply to XRF with MNPS, because this type of XRF system does not use a USERVAR.

**Related Reading:**

- For information on the contents of the BIND data, see “Finance Communication System Bind Parameters” on page 503.
- For specific information on where IMS adds the USERVAR variable to the user data field, see Note 5 in Table 72 on page 503.

SLU P systems are normally defined as class-1 terminals; in most cases in an XRF complex, when an alternate IMS takes over processing from an active IMS, the takeover is accomplished without losing class-1 terminal sessions. The terminals might or might not be aware of the takeover.

**Related Reading:** For information on takeovers that are not apparent, see “Writing the Controller Application Program for XRF Systems” on page 438.

If you are connecting the 4730 Personal Banking Machine to an XRF IMS as a SLU P device, use the following machine data configuration options:

- Invalid message: 10 or 11
- Multiple commands: 10 or 11

The first digit (1) prevents the 4730 from sending an exception response to certain network messages, including the DFS3861 message sent after an XRF takeover. Exception responses to these messages terminate the SLU P session between the 4730 and IMS. The second digit (0 or 1) indicates whether errors should be logged.

**Related Reading:** For more information on the 4730, see *IBM 4730 Personal Banking Machine Operations Support Manual*.



## Bracket and Send/Receive Management

The change-direction and bracket indicators are used to begin, end, and control the direction of synchronous transmissions between a SLU P system and IMS. IMS support of these indicators is summarized in Table 67 (X = supported).

*Table 67. Use of VTAM Bracket and Change-Direction Indicators*

Synchronous Transmissions	BB	EB	BB/EB	BB/CD
Received by IMS with data	X		X	X
Sent by IMS with data		X	X	
Received by IMS with data flow synchronous commands (normal flow)		X		

IMS does not support the absence of bracket indicators or the use of end-bracket-only on inbound synchronous data. IMS does not send output synchronous data with begin-bracket (BB) only, change-direction (CD) only, or BB/CD. Because IMS always ends a bracket (unconditional bracket termination) on input synchronous data, it is unnecessary to send either EB or CD on output synchronous commands. Input synchronous commands can specify EB or CD, but must be consistent with the current bracket and send/receive states; otherwise, the session is terminated. IMS does not send VTAM indicators with data flow synchronous commands (normal flow).

## Bracket and Send/Receive Management

---

## Chapter 22. IMS Facilities Used for SLU P and Finance

This chapter describes in detail the IMS facilities that support the Systems Network Architecture (SNA) environment.

### **In this Chapter:**

- “Component Definition”
- “Terminal-Response Mode” on page 447
- “Defining a Workstation for Terminal-Response Mode” on page 448
- “Output Messages Sent While in a Between-Brackets State” on page 449
- “Designing for Output Messages Sent While in Between-Brackets State” on page 450
- “IMS Message Format Service” on page 450
- “Display Screen Protection for Finance Stations” on page 453
- “Extended Output Component Protection (SLU P)” on page 453
- “Input and Output Editing Options (SLU P)” on page 455
- “Use of Responses or Brackets to Acknowledge Recoverable Input” on page 456
- “Message Recovery” on page 457
- “Message Resynchronization” on page 458
- “Finance and SLU P in an XRF Complex” on page 459
- “Fast Path Messages with Finance and SLU P” on page 459

---

### Component Definition

**Definition:** IMS considers a *workstation* to be one physical terminal. If a workstation is made up of more than one device, each physical device that makes up the workstation must be defined as a component of that workstation. As such, each component can have an IMS logical terminal (LTERM) associated with it. One LTERM is associated with each component. A user-written MPP can address specific components of a workstation through the appropriate LTERM.

IMS assumes that all input is from the first LTERM in the component list that passes the necessary operational and security checks. Message switches, broadcast messages for specific logical terminals, and data replies to transactions are directed to the component associated with the specified output LTERM.

### LTERM Naming

To facilitate the use of the CHNG call, define a convention for naming LTERMs. One method is to set the LTERM name to be a combination of the workstation and component identifiers.

**Example:** IMS considers the 4704 keyboard and display system components as one component, the 4706 magnetic stripe reader as another component, and the 4710 receipt printer as yet another component. Thus, workstation 100 can have three components: WS100DS (4704), WS100MS (4706), and WS100RP (4710). Such a standard permits an MPP to interrogate the I/O PCB (LTERM name field) to identify the workstation and then to specify the proper alternate PCB for output using the CHNG call.

## Component Definition

For a multiple-component terminal, such as a SLU P, you must ensure that IMS creates enough queues to service the terminal. You can use an exit routine or a specific user descriptor for that unique logical unit to ensure that IMS creates the required number of queues.

## Output Component Selection

IMS system definition allows a workstation to have a maximum of four output components. If more than four output components are required for a workstation, or multiple LTERMs are not desired, a user-defined MPP-to-workstation protocol and data format must be provided. Workstation components are assigned an identification number: X'01', X'02', X'03', and X'04'. For Finance terminals, the identification number is based on the order in which they are defined. For SLU P terminals, the identification number defaults to Comp<sup>1</sup>, (Program1, Basic). IMS nonqueued system messages have no specific destination and are directed to the first component.

An IMS Transaction Input edit routine can be used to append the station's node name to the input message. The MPP can reference the node name to determine which LTERM name to use for output. For terminals created using the Extended Terminal Option (ETO) feature, append the user name to the input message because the user could be signed off.

**Related Reading:** For more information on the ETO feature, see Chapter 9, "Administering the Extended Terminal Option," on page 147.

To return a reply message to a workstation operating in terminal response mode, or to a conversational transaction, the MPP must insert the reply to the I/O PCB. However, for some stations, that reply message might be intended for a component other than the one associated with the LTERM specified in the I/O PCB. Because the destination of the I/O PCB cannot be modified by the CHNG call, an alternate PCB type is required. The alternate PCB type must fulfill these response requirements and also be modifiable. The PCB type, called the response alternate PCB, can be defined using PSBGEN. This PCB can be used instead of the I/O PCB to return reply messages to conversational transactions and to stations operating in terminal response mode. It can also be defined as modifiable. This allows the CHNG call to be used with this PCB to select the appropriate destination for the reply. When the CHNG call is used, the LTERM specified in the call must be assigned to the same physical terminal as the LTERM specified in the I/O PCB. If this is not the case, a status code is returned on the ISRT call.

## Input Component Determination

Proper relationships between input and output components can be established using the NAME macro during IMS system definition, or by using an ETO user descriptor and the Signon exit routine. This relationship allows the terminal to specify its input component and causes output to be returned to a component that is defined during IMS system definition. Proper definition and use of input components can reduce or eliminate the need for LTERM naming conventions, MPP change calls, and inserts to alternate PCBs.

A user can establish a connection for SLU P usage by defining a component for each of the operators, devices, or processing requirements controlled by a remote application program.

IMS performs input component selection for the remote logical units and assumes that all input is from the first LTERM in the list that passes the necessary

operational and security checks. For input from SLU P, input component selection is performed based on the component indicated in an optional input message header. If no function management header is received, IMS assumes the input is to be associated with the LTERM for component 1. Message switches, broadcast messages for specific LTERMs, and data replies to transactions are directed to the component associated with the specified output LTERM.

---

## Terminal-Response Mode

**Definition:** *Terminal-response mode* is a mode of operation that can be defined for transactions, users, and terminals attached to IMS. When a SLU P station is operating in terminal-response mode, all operations are stopped between the workstation and IMS from the time IMS receives a transaction until IMS receives acknowledgment that the reply message has been received by the workstation. For normal IMS output messages, this acknowledgment is the receipt of the DR2 response requested for recoverable transaction output. For Fast Path output messages, this acknowledgment is the receipt of the next input message or an RTR command. For MFS-paged output messages, this acknowledgment is the receipt of the next input message, MFS NEXTMSG or NEXTMSGP control commands, or a requested DR2 response (if not Fast Path output) on the last page of the message. Output caused by a nonrecoverable transaction requests an exception DR2 response and does not require a response from the workstation. Terminal-response mode can reduce the processing required by the controller application program.

Terminal-response mode can be selected by an installation during IMS system definition or with an ETO user descriptor. Your system can be defined as forced, negated, or transaction-dependent:

- If it is defined as forced, every input transaction is in terminal-response mode.
- If it is defined as negated, no input transaction is in terminal-response mode.
- If it is defined as transaction-dependent, terminal response mode is determined on a transaction-by-transaction basis. The use of transaction-dependent terminal-response mode can make the controller application programs more complex, because they must handle communication protocols resulting from both forced and negated terminal-response mode environments.

Terminal-response mode can only be invoked by valid transactions, not by message switches, IMS commands, VTAM commands and indicators, or MFS control requests. Transactions that are unacceptable (for example, because of a security violation or an invalid transaction code) cannot invoke terminal-response mode.

When a workstation is operating in terminal-response mode, the following processing occurs after the workstation has established a session with IMS:

1. The workstation sends an input transaction.
2. IMS places the workstation in terminal-response mode.
3. IMS passes the transaction to a message processing program (MPP).
4. The MPP processes the transaction.
5. The MPP returns a reply, using either the I/O PCB or an response alternate PCB.
6. IMS returns a DRx response, if one is requested.
7. IMS sends the reply to the workstation.
8. The workstation returns a DR2 response, if one is requested.
9. IMS removes the workstation from terminal-response mode.

## Terminal-Response Mode

While a workstation is in terminal-response mode, IMS accepts no input from it, and sends no output to it other than the reply from the MPP. If the MPP abends while processing the input transaction, IMS might send an exception response and the associated IMS error message. Any output that is not in reply to the transaction that initiated terminal-response mode is held in IMS's output queue. After IMS removes the workstation from terminal-response mode, it sends the unsolicited output.

When Fast Path is used, the following processing occurs:

1. The workstation sends an input transaction.
2. IMS places the workstation in terminal-response mode.
3. IMS passes the transaction to a Fast Path message processing program (IFP).
4. The IFP processes the transaction.
5. The IFP returns a reply, using either the I/O PCB or a response alternate PCB.
6. IMS returns DRx, if one is requested.
7. IMS sends the reply to the workstation.
8. An exception DR2 response is required on output; therefore, the workstation sends the next input message or RTR command. If IMS has output for the workstation on the message queue, a definite response is required. The workstation sends DR2.
9. IMS removes the workstation from terminal-response mode.

---

## Defining a Workstation for Terminal-Response Mode

You must understand the operation sequences described in "Terminal-Response Mode" on page 447 before defining a workstation to operate in terminal-response mode. Less processor time is required for stations that operate in terminal response mode, and the controller application program that controls such a workstation might also be less complex. The following considerations also apply:

- Typical data collection applications cannot be performed from stations that operate in terminal-response mode. In this mode, a reply from the MPP is required for each transaction before IMS accepts another transaction. Waiting for this response extends the time of the data entry process.
- IMS does not send a response to an input message until the output reply is available. Thus, when the response is returned, it indicates that the input has been processed and the application has reached a sync point.
- While a workstation is in terminal-response mode, IMS does not attempt to obtain any more input from that station. Master terminal operator intervention is required if an error prevents creation or transmission of a reply. Some conditions can prevent a reply being sent to the workstation. These include:
  - The LTERM stopped.
  - IMS was unable to schedule an MPP (database stopped, MPP stopped).
  - An MPP logic error caused no reply to be returned except for EMH (expedited message handler), which generates a zero-length reply.

If any of these conditions occurs, the workstation is temporarily inoperative. Before the workstation can be used again, the master terminal operator must diagnose and correct the error.

- A response message remaining on the IMS output queue or inserted by the user-MPP after session termination is re-sent after initiation of the next session. If the BID option is specified, this message is preceded by the VTAM BID command. Both the begin-bracket and end-bracket indicators are sent with the message.

System analysts must evaluate these factors for their own system application programs and operating environment.

---

### Output Messages Sent While in a Between-Brackets State

If an IMS output message is sent while the workstation is not protected from output and in a between-brackets state, IMS sends either:

- The message with both the begin- and end-bracket (that is, bids for bracket with data) if the workstation is defined with the NOBID option
- The BID command to request permission to begin a bracket if the workstation is defined with the BID option.

**Related Reading:** For information on when an IMS output message is sent while the workstation is not protected from output, see “Display Screen Protection for Finance Stations” on page 453.

A workstation can accept the bracket with any requested DR1 or DR2. A DR1 to the bid causes IMS to send the output message with both begin- and end-brackets.

A workstation can reject the bracket with an appropriate exception DR1 or DR2.

**Related Reading:** For information on the IMS operation that follows a bracket rejection, see “Controller or Station-Detected Errors” on page 491.

When a workstation is ready for output after rejecting a bracket, it sends the ready-to-receive (RTR) command to request output from IMS.

The following steps show how IMS handles output for a workstation that is in terminal-response mode and that is defined with the BID option when the session is between-brackets:

1. When IMS receives a message switch for a workstation defined with the BID option, IMS places the message in the output queue.
2. After removing the workstation from terminal-response mode, IMS sends a BID command to notify the workstation that output is pending while between-brackets. IMS requests a DR1 response to the BID command.
3. The workstation returns the DR1 response if it is ready to receive the output.
4. IMS sends the output when it receives the DR1.
5. The workstation returns a DR2 response, if requested.
6. If the workstation is not ready to receive the output, it returns an exception DR1 response indicating “bid rejected”. If the output is recoverable, IMS returns the message to the queue and waits until the workstation indicates it is ready to accept the output. If the exception response indicates “RTR will not follow” and the output is nonrecoverable, IMS discards it. If the exception response indicates “RTR will follow,” IMS returns the message to the queue (regardless of recoverability) and waits for a VTAM ready-to-receive (RTR) command.
7. When the workstation is ready to receive the output, the workstation sends the VTAM RTR command and requests a DR1 response.
8. If the output message that caused the bid is still available, IMS returns the DR1 response, followed by the output message.
9. The workstation returns a DR2 response (12).

## Output Messages Sent While in a Between-Brackets State

While IMS waits for the RTR command from the workstation, the workstation can perform any type of processing desired. IMS accepts and responds to transactions during this time, but does not transmit any unsolicited output until it receives the RTR command.

If IMS no longer has output available to send when the workstation sends RTR (perhaps because of an intervening /ASSIGN or /DEQUEUE command), or if the data was irrecoverable and IMS discarded it, IMS returns an exception DR1 response and an error message indicating no output is available.

---

## Designing for Output Messages Sent While in Between-Brackets State

If IMS receives an exception response to an irrecoverable output message (inquiry-only transaction), the message is lost, because IMS dequeues the message immediately upon sending it to VTAM. When IMS is between-brackets, it sends the BID command to bid the workstation before actually sending an output message. If the bid is rejected, the recoverable output message remains queued if the exception sense data indicates an RTR is forthcoming; otherwise, the message is discarded. These concepts are described in “Output Messages Sent While in a Between-Brackets State” on page 449 and should be reviewed in conjunction with the IMS actions described under “Controller or Station-Detected Errors” on page 491.

---

## IMS Message Format Service

This topic describes some IMS MFS facilities that specifically apply to the SLU P system.

**Related Reading:** For more information on IMS MFS facilities for SLU P, see *IMS Version 9: Application Programming: Transaction Manager*.

## Designing MFS for the Workstation Environment

Both input and output data can be processed by MFS. The exit for the Input Transaction edit routine is available to provide additional editing capabilities.

The availability of MFS to workstations is defined on an individual basis by the system administrator during IMS system definition. When MFS is defined as available, each input or output message can optionally be processed using MFS. The format of messages to be processed by MFS is defined using the IMS-supplied MFS Language utility.

Operations using MFS can be quite different from operations using the IMS Basic Edit facilities. Device formats and operator procedures should be designed carefully, with the objectives of easy use and high-operator productivity.

MFS provides two levels of message formatting: device-level message formatting and distributed presentation management (DPM). Device-level message formatting is for Finance logical units. DPM support is for SLU P logical units.

To prevent null screens, a null record (data length = 0) produced by MFS as the result of a user-specified MFS format description is not sent by IMS.

## MID/MOD Chaining

MFS input formatting for a workstation occurs when a message input descriptor (MID) name is provided with an input message. The MFS message output



descriptor (MOD) can supply a MID name to be used for formatting the next input message. It is the responsibility of the workstation to supply this MID name when it sends the input message. This results in supplying the MID name.

**Related Reading:** For more information on the MID name, see “Activating MFS Input Formatting for Finance Workstations” on page 478.

MID/MOD chaining can be accomplished with little or no intervention by the workstation operator by observing the following procedure during the design of SLU P system application programs:

1. Remove the MID name from the received output message header and save it for use on the next input message.
2. Display or print the output message.
3. Get the next operator input.
4. Add the MID name saved in step 1 to the transaction.
5. Send the transaction to IMS.

**Related Reading:** For more information on the MID/MOD chaining concept, see “MFS Application Design” in *IMS Version 9: Application Programming: Transaction Manager*.

## MFS Output Formatting for the SLU P System

MFS can be used to format pages, produce standard headings and footings, and provide forms control. Without MFS, the message processing program (MPP) or the controller application program must provide these functions.

Using MFS can also provide MPP device independence and allow SLU P components to be used for low-volume applications invoked from any of several terminal types. This device independence allows the controller application program to concentrate on high-volume applications, reducing its complexity and maintenance work.

The availability of MFS to a workstation is defined on a station-by-station basis by the system administrator during IMS system definition or ETO logon descriptor definition.

## MFS Message Recovery

Input messages processed by MFS are edited before the message is queued and logged. Output messages are edited immediately prior to transmission; therefore, for recovery purposes, an input message is formatted by MFS and an output message is formatted by the IMS application program.

## MFS Control Functions (Finance)

The control functions available to the operators of devices using MFS are:

### Page Advance (NEXTPP)

Transmit the next physical page of the current message, if one exists.

### Logical Page Advance (NEXTLP)

Transmit the first or only physical page of the next logical page of the current message.

## IMS Message Format Service

### Logical Page Requests

PAGEREQ=nn where nn is the number of the logical page desired. If the request is valid, transmit the data fields defined in the specified logical page of the current message.

### Message Advance Protect (NEXTMSGP)

Discontinue printing or displaying the current output message and begin transmitting the next message in the output queue. If none exists, return an exception DR2 to notify the operator.

### Message Advance (NEXTMSG)

Discontinue printing or displaying the current output message and begin transmitting the next message, if any.

These control functions can be indicated to MFS by including them in input function management headers or by defining an operator control field within the input data to MFS.

## MFS Control Functions (SLU P)

The following device-level MFS control functions are available to logical units defined as SLU P. SLU P terminals process the DPM-formatted output messages that specify paging option on the MFS device format. The paging option can be OPTIONS=DPAGE or OPTIONS=PPAGE.

### Page Advance (NEXTTPP)

If a current message with OPTIONS=PPAGE is defined, transmit the data fields defined in the next presentation page. If a current message with OPTIONS=DPAGE is defined, transmit the data fields defined in the next logical page.

### Logical Page Advance (NEXTLP)

Transmit the data fields defined in the next logical page of the current message if one exists and if either OPTIONS=PPAGE or OPTIONS=DPAGE is specified.

### Logical Page Request

PAGEREQ=nn, where nn is the number of the logical page desired. If the request is valid, transmit the data fields defined in the specified logical page of the current message.

### Message Advance Protect and Message Advance (NEXTMSGP and NEXTMSG)

Discontinue transmitting the current output message and begin transmitting the next message in the output queue.

The control functions of NEXTTPP, NEXTLP, NEXTMSGP, and NEXTMSG can be specified in input function management headers or by defining an operator control field within the input data to MFS. Logical page requests can only be entered within the input data or using the operator control field.

## MFS Paging and BID Options

The BID option provides output protection but has a high performance cost (an extra line flow for each message). When the BID option is specified and the output occurs while between-brackets, IMS waits for a positive response to BID before sending output. To avoid sending BID while sending MFS-paged output, each

input paging request should indicate begin-bracket and change-direction. Each output page then contains only end-bracket and no BID results, because the page is sent while in an in-brackets state.

---

## Display Screen Protection for Finance Stations

When a Finance station is defined with the NOBID option, IMS provides support similar to the screen protection function for the IBM 3270 Information Display System. IMS does not transmit two consecutive output messages to a display component without an intervening input message from the component. This gives the user the opportunity to view and respond to one message before another is displayed.

When IMS transmits an output message to a display component, it marks the component as protected, unavailable for output. IMS does not transmit another output message to it until an input message is received from that component. The input message can be an IMS transaction, a message switch, an IMS command, the VTAM RTR command, or an MFS control request. Upon receipt of one of these, IMS changes the display component's status to unprotected.

When a workstation is defined with the BID option, consecutive messages are not transmitted to a station. Input from the workstation or a positive response to the BID command from IMS must be received after one transmission before the next message can be sent.

When a workstation uses MFS, the screen is protected on a physical-page basis. MFS control requests or input data are used to request additional screens of data.

**Related Reading:** For more information on physical page control, see "MFS Control Functions (Finance)" on page 451.

If a workstation does not use MFS, the screen is protected on a message-by-message basis. The input of any IMS transaction, message switch, or command causes the screen to be unprotected. The VTAM ready-to-receive (RTR) command can be used to request the next output message. If no message is available, or if the node is in a status that does not allow output to be sent (output stopped or quiesced), IMS returns an exception DR1, followed by an error message indicating that no output is available.

If the RTR command is received during the transmission of MFS-paged output, IMS returns an exception DR1 response, followed by an error message indicating an invalid paging request, because IMS cannot determine the MFS control function to be performed.

After an exception response is received by IMS for a current IMS output message to a display component, the screen is unprotected. After an exception response is sent by IMS, any defined display component is automatically marked protected and unavailable for output.

---

## Extended Output Component Protection (SLU P)

When a SLU P is defined with the NOBID option, IMS provides support similar to the screen-protection function for the IBM 3270 Information Display System and display-screen protection for Finance components. IMS does not transmit two consecutive output messages to an output-protected component without an appropriate intervening input message from the LU. This gives the LU an

## Extended Output Component Protection (SLU P)

opportunity to process one message, according to user-defined procedures, before another is sent to the same component. SLU P support allows the output of all components to be protected.

IMS marks the component as protected and unavailable for output under the following conditions:

- When IMS transmits a message to a component defined as PROGRAM2 on the IMS TERMINAL macro
- When IMS transmits a message (or a page of a message) formatted by MFS with a paging option defined

While a component is protected, IMS does not transmit another output message to the component until an input message from the logical unit resets the component to unprotected. Input messages that can reset a component's status to unprotected are:

- An IMS transaction with an FM header
- A message switch with an FM header
- An IMS command with an FM header
- An MFS control request with an FM header indicating a specific component to be unprotected
- Any of these, either without an FM header or with an FM header indicating component zero (which resets protection on all components of a terminal)
- An RTR command

After the component's status is reset to unprotected, IMS sends any available output. If a component is defined as PROGRAM2 and is not described by a device format with paging OPTIONS=DPAGE or OPTIONS=PPAGE, output to the component is protected on a message-by-message basis. The input messages are used to reset output component protection.

If a SLU P component is defined to use MFS DPM and the device format used is defined with the paging option OPTIONS=DPAGE or OPTIONS=PPAGE, the output component is set to protected when a logical page or presentation page is sent to the component. MFS control requests or input data are used to reset output component protection and request additional logical or presentation pages from MFS.

**Related Reading:** For more information on logical page control, see "MFS Control Functions (SLU P)" on page 452.

During the transmission of MFS-paged output, the only allowable input is:

- Input containing no message header (resets all components' protection).
- Input containing a header indicating the specific component to which MFS is currently paging. Otherwise, the session is terminated, because IMS cannot simultaneously send output to more than one component of a terminal.

If a SLU P terminal is defined with the BID option, output component protection occurs after every message. In this mode of operation, consecutive messages are not transmitted to a terminal. Input from the terminal must be received; otherwise, if additional output is queued, a BID command is sent after one transmission before the next message is sent.

## Extended Output Component Protection (SLU P)

If a terminal does not use MFS, screen protection is performed on a message-by-message basis. The input of any IMS transaction, message switch, or command causes the screen to be unprotected.

If the ready-to-receive (RTR) command is received and no messages are available, or if the terminal is in a status that does not allow output to be sent (output stopped or quiesced), IMS returns an exception DR1, followed by an error message indicating no output is available. If the RTR command is received during the transmission of MFS-paged output, IMS returns an exception DR1 response, followed by an error message, indicating invalid paging request because IMS cannot determine the MFS control function to be performed.

After any exception response is sent by IMS, any display component defined for the logical unit is automatically marked protected and unavailable for output.

After an exception response is received for a current IMS output message to a component defined as PROGRAM2 or for an MFS DPM-paged output message, the component to which the output was sent is left unprotected.

After any exception response is sent by IMS, all components defined as PROGRAM2 are automatically marked protected and unavailable for output.

---

## Input and Output Editing Options (SLU P)

The type of editing subparameter in the COMPTn parameter of the system definition TERMINAL macro and the Extended Terminal Option (ETO) logon descriptor can be indicated at a component-by-component level for input to and output from components defined as SLU P.

**Related Reading:** For more information on the ETO feature, see Chapter 9, "Administering the Extended Terminal Option," on page 147.

The four types of editing provided are:

- |                   |  |
|-------------------|--|
| <b>BASIC</b>      | Requests that no deblocking be performed on input to IMS. MFS cannot be used on input or output.   |
| <b>BASIC-SCS1</b> | Requests that deblocking occur when an SNA character string (SCS)-defined new line (NL-X'15') or form feed (FF-X'0C') character is sent to IMS. MFS is not used on input or output.      |
| <b>MFS-SCS1</b>   | Requests that deblocking occur when an SCS-defined new line (NL-X'15') or form feed (FF-X'0C') control character is sent to IMS. MFS-SCS1 formats can be used for both input and output. |
| <b>DPM-An</b>     | Allows messages to be formatted using MFS distributed presentation management (DPM). No deblocking on input to IMS is performed. 'n' is a number from 1 to 15.                           |

For DPM, the device type symbolic name is specified to MFS as DPM-Xn, where X is A or B. Message formatting is specified on the TERMINAL macro for logical units defined as SLU P by using device type symbolic names of the form DPM-An. DPM-Bn device type symbolic names refer to logical units defined for Intersystem Communication (ISC).

If BASIC or SCS1 is specified, each message received or sent by IMS as one or more related transmissions forms a VTAM chain:

## Input and Output Editing Options (SLU P)

- For BASIC, each input transmission to IMS, less any supplied input FM header, is treated as an IMS segment to be presented to MFS or directly to the IMS message processing program.
- For SCS1, an IMS input segment is created at each SCS-defined new line or form feed control character. IMS segments can be created from a portion of, from all of, or from more than one spanning transmission.

For either BASIC or SCS1, each output segment is sent by IMS in a single transmission, unless it and any IMS-appended FM header are larger than the logical unit's buffer size as indicated to IMS by the OUTBUF parameter on the system definition TERMINAL macro or on the ETO logon descriptor. In this case, IMS sends the segment in as many transmissions as required. Each transmission, except possibly the last transmission of a segment, is the maximum-defined output buffer size.

**Related Reading:** For a definition of SCS1, see Appendix E, "SNA Character String Controls," on page 523.

When DPM or MFS-SCS1 is specified, input and output messages can be formatted by MFS DPM or MFS-SCS1, respectively, on a message-by-message basis. Messages that are not to be formatted are edited as previously described for BASIC or SCS1.

**Related Reading:** For information on MFS formatting, see *IMS Version 9: Application Programming: Transaction Manager*.

---

## Use of Responses or Brackets to Acknowledge Recoverable Input

To facilitate message resynchronization, IMS allows an input update or a recoverable-inquiry transaction to optionally request a definite response. IMS allows this request for a definite response if the user specifies the OPTIONS=OPTACK for the workstation.

**Related Reading:** For more information on requesting a response, see the description of the TERMINAL macro in *IMS Version 9: Installation Volume 2: System Definition and Tailoring*.

With this operand specified, IMS can acknowledge input with the next output through use of the input and output bracket indicators.

**Restriction:** OPTIONS=ACK is not supported for SLU P terminals created using the ETO feature.

### **Related Reading:**

- For more information on ETO, see Chapter 9, "Administering the Extended Terminal Option," on page 147.
- For information on the specific effects of the OPTACK option on message resynchronization, see "Message Resynchronization" on page 458.
- For information on the use of OPTACK= with Fast Path, see "Fast Path Messages with Finance and SLU P" on page 459.

If the OPTACK option is defined, performance can be improved if the workstation requests begin-bracket, change-direction, and exception DR1 or DR2 (rather than DR1 or DR2) on recoverable input to IMS. The next output from IMS acknowledges the input by indicating end-bracket only. The type of output

## Use of Responses or Brackets to Acknowledge Recoverable Input

messages that are sent from IMS depend on the type of recoverable input, the defined response mode, and the availability of output.

**Related Reading:** For information on the types of output messages, see Chapter 24, “SLU P Message Protocols,” on page 475 and “MFS Control Functions (Finance)” on page 451.

Contention can occur when a session is in a between-brackets state. In this case, IMS sends an unsolicited output message indicating both BB and EB or a BID command at the same time that the workstation is sending an input message indicating begin-bracket and change-direction. This output message does not acknowledge the input message and can be either accepted or rejected by the workstation. Rejecting an IMS nonrecoverable output message can result in losing the message. If contention occurs when IMS is sending a recoverable IMS output message (output requesting DR2 response), the workstation must send either an exception or a definite response before IMS can receive the input message.

**Related Reading:** For more information on rejecting an IMS irrecoverable output message, see “Output Messages Sent While in a Between-Brackets State” on page 449.

---

## Message Recovery

The process of message recovery is accomplished within IMS by using the IMS system log and the checkpoint and restart routines. Recovery is possible, because IMS has direct control of the communication link. With a SLU P system, however, this control is shared with the controller and the controller application program. If a network failure, such as a processor failure or an IMS abend, occurs while the controller application program is receiving a message from IMS, the traditional methods of IMS recovery cannot always detect the lost message. The IMS recovery methods are extended for the SLU P systems to include the controller application program for message resynchronization.

The controller application program participates in message resynchronization so that a lost message condition, if any, can be detected and corrected. Failure of the controller application program to perform its responsibilities during message resynchronization results in a loss of message integrity in the system.

Message resynchronization is necessary for a workstation when a session with the workstation is terminated between the time it sends a recoverable message and the time it receives a reply for that message. The type of resynchronization depends on how the message is defined.

For all messages except response mode, response conversational mode, and Fast Path, the input becomes recoverable when it has been successfully enqueued and made available for scheduling. During message resynchronization, IMS indicates the last successfully received recoverable message.

For response mode, response conversational mode, and Fast Path, the input is not made recoverable and restartable until the application reaches its first sync point. If the IMS system fails before this sync point, the message is considered to be nonrestartable. During message resynchronization, IMS indicates whether the message has reached a sync point or needs to be reissued.

If a session with a workstation is terminated after IMS sends a message to the workstation but before IMS receives the response, message resynchronization is

## Message Recovery

necessary for this workstation. The output message for which no response is received must remain associated with this workstation until message resynchronization determines whether the workstation received the message. If the /ASSIGN command is used to move the message to a different workstation, message resynchronization is no longer possible.

---

## Message Resynchronization

The purpose of message resynchronization is to guarantee the integrity of messages across sessions. Message resynchronization occurs at the start of a session unless IMS is cold started. Finance and SLU P sessions warm start using the control blocks created from the original descriptor, even though that descriptor might have been changed or deleted after IMS created the control blocks. Only a coldstart ensures that the control blocks that are created represent the new or updated descriptor.

When message resynchronization is necessary because of a network failure, the resynchronization must complete successfully before IMS permits normal data transmission. To initiate message resynchronization, IMS sends the VTAM set-and-test-sequence-numbers (STSN) command. The LU must respond to this command. To be able to respond properly, a copy of the following must be maintained:

- The sequence number of the last request unit (RU) of the last inbound sync-point message that was sent by the LU. The inbound sync-point message is one of the following:
  - The last successful recoverable input message (the one that requested a DR1 or DR2) if the ACK option was defined to IMS for this LU
  - The last input message, if the OPTACK option was defined for this LU
- The sequence number of the last request unit (RU) of the last outbound sync-point message received by the LU. The outbound sync-point message is the last successful recoverable output message. Recoverable output messages are those requesting DR2 responses.

If Fast Path is used, each output message is recoverable and requests an exception DR2. These Fast Path-recoverable messages are identified by a flag within the output message header, rather than by an explicitly requested DR2 response.

Optionally, the LU can maintain a copy of the last inbound recoverable message sent by the terminal. If this is done, the SLU P system can retransmit, after resynchronization, any message not received by IMS.

**Restriction:** Session initiation and resynchronization caused by an SNA Request-Recovery (RQR) command is not allowed when the node is in response mode and the response reply message is not yet available for output; that is, the input response mode transaction is still queued or in the process of execution. Response-mode transactions are not recoverable or restartable prior to the application sync point; therefore, session input acknowledgement does not occur until input processing is complete.

Session initiation or resynchronization results in session termination while the response mode transaction is in this 'indoubt' state, and IMS is not able to indicate that the associated input sync-point request was committed or backed out. This temporary error condition is indicated to the master terminal operator by message DFS2081I. An IMS /DISPLAY command can be used to determine when the response mode reply message is available and session initiation can again be



attempted. A display status of RESP-INP indicates input is still in process; RESP indicates input processing is complete and output is available for transmission.

---

## Finance and SLU P in an XRF Complex

Finance and SLU P sessions are handled as Class 1, 2, or 3 terminals. Class 1 attempts to provide a maximum level of transparency and performance by tracking the active IMS session with a standby session on the XRF backup system. Class 2 and 3 support involves terminating the active session if the IMS system fails. At takeover, the alternate IMS system automatically reinitiates the session and automatically signs on the original active system user if necessary. Class 3 support requires manual session restart and signon after XRF takeover.

### Related Reading:

- For information on establishing a Finance or SLU P session with an XRF complex, see “Establishing Connection with the XRF Complex” on page 442.
- For more information on XRF, see *IMS Version 9: Operations Guide* and *MVS/ESA Planning: Extended Recovery Facility (XRF)*.

---

## Fast Path Messages with Finance and SLU P

When using Fast Path, the following options must be specified in the TERMINAL macro:

### **OPTACK**

Allows input messages containing begin-bracket and change-direction indicators to be acknowledged by an end-bracket indicator on the next output message.

### **FORCERESP or TRANSRESP**

Allows input of a response mode message to IMS.

To obtain best performance, Fast Path input messages should not request definite responses but should be coded with begin-bracket, change-direction, and exception DR2 response.

### **FPACK/NFPACK**

Determines if special Fast Path output protocols should be used.

Fast Path transactions are single-segment transactions and are defined as recoverable. Fast Path transactions must be defined as response mode.

Related Reading: For more information on Fast Path output messages, see “Fast Path Output Messages (Finance).”

## Fast Path Output Messages (Finance)

When defined with the system definition TERMINAL macro option FPACK or an ETO logon descriptor, Fast Path output messages are sent requesting an exception DR2 response. Fast Path output is sent requesting DR2 response when:

- Queued output is available to be sent to any nondisplay component.
- The system definition TERMINAL macro option BID or an ETO logon descriptor option BID is defined, and queued output is available to be sent to a display component.
- The system definition TERMINAL macro option NOBID or an ETO logon descriptor option NOBID is defined, and queued output is available to be sent

## Fast Path Messages with Finance and SLU P

to a display component when the Fast Path output reply message is directed to a nondisplay component. The Fast Path output does not result in the display component being screen protected.

Unlike non-Fast Path output, the output message is left outstanding (not dequeued), and the workstation remains in response mode until the workstation sends data, a ready-to-receive (RTR) command, or the DR2 response to cause the message to be dequeued. The RTR command should be considered when no input is to be generated for an abnormally long time (for example, when the terminal operator plans to leave the terminal). The input message from the workstation, the RTR command, or the DR2 response acknowledges that the preceding output has been received and is recoverable; therefore, IMS might dequeue the output message, process any input message, or send any available output.

The system definition TERMINAL macro option NFPACK or an ETO logon descriptor indicates that the Fast Path output exception DR2 and next input acknowledgment protocol should not be used. In this case, Fast Path output messages are always sent requesting standard recoverable output message response protocols (DR2 response).

When the DR2 response is received, IMS dequeues the output message, removes the terminal from response mode, and sends any available queued output. Queued output is not sent to a display component if the Fast Path output reply message is sent to the same component because of the IMS screen protection support.

**Related Reading:** For more information on IMS screen protection support, see “Display Screen Protection for Finance Stations” on page 453.

## Fast Path Output Messages (SLU P)

When defined with the system definition TERMINAL macro option statement FPACK or an ETO logon descriptor, Fast Path output messages are sent requesting an exception DR2 response when any of the following occurs:

- Queued output messages are available to be sent to a component defined for the workstation as PROGRAM1.
- The system definition TERMINAL macro option BID or an ETO logon descriptor option BID is defined, and queued output is available to be sent to a component defined for the workstation as PROGRAM2.
- The system definition TERMINAL macro option NOBID or an ETO logon descriptor option NOBID is defined, and queued output messages are available to be sent to a program. This component is not output protected due to a previous output or this Fast Path message. (That is, multiple components might be protected or reset selectively as defined in this chapter.)

Unlike non-Fast Path output, the output message remains outstanding (not dequeued) and the terminal remains in response mode until the terminal sends data, a ready-to-receive (RTR) command, or the DR2 response to cause the message to be dequeued. The RTR command should be considered when no input is to be generated for an abnormally long time (for example, when the terminal operator plans to leave the terminal). The input message from the terminal, the RTR command, or the DR2 response acknowledges that the preceding output has been received and is recoverable; therefore, IMS might dequeue the output message, process any input message, or send any available output.

The system definition TERMINAL macro option NFPACK or an ETO logon descriptor indicates that the Fast Path output exception DR2 and next input

acknowledgment protocol should not be used. In this case, Fast Path output messages are always sent requesting standard recoverable output message response protocols (DR2 response).

When the DR2 response is received, IMS dequeues the output message, removes the terminal from response mode, and sends any available queued output for PROGRAM1 components or non-output protected PROGRAM2 components defined for the workstation. Output protection is set at the component level during output for PROGRAM2 components and can be selectively reset for one or more components based on subsequent input.

**Related Reading:** For more information on output protection for PROGRAM2 components, see "Extended Output Component Protection (SLU P)" on page 453.

Also use the NFPACK option for all 4730 terminals. This allows any asynchronous output messages to be sent immediately following the acknowledgement of the Fast Path output reply.

### Fast Path Message Resynchronization

If Fast Path is defined, sequence number management and message resynchronization might require change.

**Related Reading:** For more information on message resynchronization, see "Message Resynchronization" on page 458.

## Fast Path Messages with Finance and SLU P

---

## Chapter 23. Network Operation for SLU P and Finance

This chapter describes how to start an IMS network, how to initiate sessions, the different transaction types, message switching, and IMS commands.

### In this Chapter:

- “Starting an IMS Network”
- “Making IMS Ready”
- “Session Initiation (Starting Workstations)” on page 464
- “Suspending Output from IMS” on page 470
- “Session Termination” on page 470
- “Shutting Down an IMS Network” on page 472
- “SLU P Messages” on page 472
- “Send/Receive and Bracket Protocol” on page 473

---

### Starting an IMS Network

Before a session with IMS can be established for any workstation:

- VTAM and NCP must be active.
- Controllers and logical units that are not activated automatically by VTAM must be activated (with a VARY command) online by the VTAM network operator.
- Controllers must be powered on, and appropriately configured, initialized, and activated for VTAM and NCP.

---

### Making IMS Ready

IMS must be made ready to receive VTAM logon (session initialization) requests. Issue the IMS /START command with the DC keyword to make IMS ready. The /START DC command tells VTAM to pass any queued VTAM logon requests (and any logon requests for workstations known to VTAM as belonging to IMS) to IMS.

The /START DC command activates the following processes:

- Initiates IMS Transaction Manager processing
- Opens the VTAM access method control block
- Enables the IMS VTAM logon exit

Any logon requests received by VTAM before the IMS /START DC command is issued, but after the IMS VTAM access method control block (ACB) has been opened, are queued in VTAM until the /START DC command processing is completed. If VTAM is active when IMS is initialized, and the DFSDCxxx PROCLIB member keyword VACBOPN=INIT, then the IMS VTAM ACB is opened. If DFSDCxxx PROCLIB member keyword VACBOPN=DELAY, then the IMS VTAM ACB open is delayed until the /START DC command is processed.

---

### Session Initiation (Starting Workstations)

**Definition:** A *session* is the logical connection of a workstation to a VTAM application program, such as IMS or the system utilities. A session must be established before data can be transmitted between a workstation and IMS. Message resynchronization is performed during session initiation, unless IMS is cold started.

Session initiation can be requested in one of the following ways:

- The workstation requests session initiation by sending the INITIATE-SELF command. VTAM verifies the command and passes the request to IMS. If the terminal is requesting a session with an IMS XRF complex, the IMS USERVAR name or the MNPS ACB should be used for the application name.
- The z/OS VTAM network operator requests session initiation on behalf of the workstation by using the VTAM VARY command with the LOGON option. VTAM processes the request and passes it to IMS.
- VTAM passes a logon request to IMS for each workstation that is defined to VTAM as belonging to IMS.
- The IMS master terminal operator requests session initiation for a workstation by entering the IMS /OPNDST command.

Regardless of how session initiation is requested, identical processing occurs when IMS receives the request.

### Session-Initiation Transmission Sequence

The following list shows the sequence of transmissions that occurs when a workstation requests session initiation. The numbers relate to major events in the sequence.

1. The controller sends the INITIATE-SELF command. VTAM checks the validity of the command, looking for syntax errors that might have been introduced by either the controller or NCP.
2. If the command is not valid or if VTAM does not find a match when verifying the initiation request, VTAM returns an EXC/DR1 response. EXC/DR1 terminates the initiation request. The SLU P system can retry the initiation request or notify the operator to begin corrective action.

If the command is valid, VTAM returns a DR1 response. VTAM then verifies the content of the resource field in the INITIATE-SELF command. This field must contain the name of the VTAM application program with which the workstation wants to enter a session. VTAM compares the resource field content to its list of active application programs (those programs with an open VTAM ACB).

3. If a match is found, VTAM passes the logon request to the specified application program (IMS).

In an XRF environment, VTAM routes the request to the currently active system.

When IMS receives the request, it compares the workstation node name supplied by VTAM to the node names defined during IMS system definition.

4. If IMS does not recognize the workstation, it issues a VTAM CLSDST command, which causes VTAM to send a procedure error command. A procedure error terminates the session initiation request. The system notifies the workstation operator that the session is denied.

If IMS recognizes the workstation, it issues a VTAM OPNDST command, which causes VTAM to send a BIND command. The BIND command contains the name of the application program (IMS) that issued the OPNDST command.

In an XRF complex that uses USERVAR instead of MNPS, the BIND command from VTAM contains the USERVAR segment in the user data field and the active APPLID in the PLUNAME field.

IMS supplies a set of BIND parameters, which define the communication rules and protocol that must be followed. IMS ignores the parameters of the mode table entry supplied by the workstation or network operator.

The workstation must respond to the BIND command.

**Related Reading:** For more information on the contents of the BIND data, see “Finance Communication System Bind Parameters” on page 503.

5. If the workstation cannot begin a session, it returns an EXC/DR1. This can occur when either VTAM or IMS is requesting session initiation and the workstation is currently unable to communicate (for example, because it is involved in offline processing).

If the workstation can begin a session, it returns a DR1. When IMS receives the DR1, it performs message resynchronization, if necessary.

6. If message resynchronization is not necessary, or when it is complete, IMS sends a VTAM start-data-traffic (SDT) command.

The workstation is in session and can transmit data to IMS.

## Controller Application Program Involvement in Message Resynchronization

The controller application program must participate in message resynchronization and, in order to do so, must have maintained copies of the sequence numbers of the last recoverable message that was successfully sent to IMS and the last recoverable message that was successfully received by the workstation.

## Design Considerations

The system application analyst must determine where to maintain the sequence numbers necessary for set-and-test-sequence-numbers (STSN) processing. Three options are available:

- The controller disk or diskette.

The disk or diskette in the controller is the most reliable method and does not require involvement of the workstation operator if retransmission of a message is required. Either the permanent file or the transient files of the disk or diskette can be used. The REPLACE instruction should be used when writing to the disk or diskette file. REPLACE causes the data to be physically written to the disk or diskette and not just buffered in the controller’s control storage. Disk or diskette storage assures sequence number retention across a power failure or a controller failure that can destroy the contents of controller’s control storage. However, disk or diskette access and data transfer time can add significant overhead to each recoverable transaction.

- The controller’s control storage.

If the controller’s control storage is used to retain sequence numbers, a power loss or controller failure would destroy the contents of the controller’s storage, making message resynchronization impossible. By not performing message resynchronization, recoverable input and output messages can be lost or duplicated.

- A workstation output device.

## Session Initiation (Starting Workstations)

Message sequence numbers can be stored on a workstation output component such as the display or the journal printer. However, this method requires workstation-operator intervention to retrieve the numbers during STSN processing.

### Sequence Number Management

An understanding of how sequence numbers are handled during normal message transmission is prerequisite to understanding how and why the SLU P system performs the functions described in this topic.

The management of sequence numbers is shared between the controller, VTAM, and the VTAM application program (IMS). The controller assigns sequence numbers to messages originated by its workstations. VTAM assigns VTAM sequence numbers to messages originated by IMS. To ensure recoverability, IMS maintains a separate copy of the sequence numbers associated with the messages it sends.

Sequence numbers are assigned to each workstation. For each workstation, the controller tracks the last sequence number that it assigns (called the *last-assigned value*), and tracks the last sequence number that it receives (called the *last-received value*). Similarly, IMS tracks the last sequence number that VTAM assigns (called the *last-assigned value*), and tracks the last sequence number it receives (called the *last-received value*).

When the controller issues a request to transmit data, it updates its last assigned value for the requesting workstation, appends the new number to the data, and sends the message. When VTAM receives the message, it merely passes it on to IMS. IMS, in turn, adds 1 to its last received value for that workstation and compares this value with the sequence number of the message it just received. If the two numbers match, IMS processes the message as required. If the two numbers do not match, IMS issues a VTAM CLSDST macro instruction to terminate the session.

When IMS has a message to transmit, it updates its copy of VTAM's last assigned value and sends the message to VTAM. VTAM updates its last assigned value, appends the new number to the message, and sends the message. The controller removes the appended sequence number, updates its last received value, and compares this value with the sequence number that accompanied the message. If the two numbers match, the controller sends the message on to the application program. If the two numbers do not match, the controller returns an exception DR2 to indicate a sequence error. When IMS receives the sequence error indication, it issues a VTAM CLSDST macro instruction to terminate the session.

### Set-and-Test-Sequence-Numbers (STSN)

Message resynchronization is initiated by IMS when it sends the set-and-test-sequence-numbers (STSN) command to the workstation. The STSN command contains a 5-byte data field:

<b>Byte 0</b>	Action code
<b>Bytes 1, 2</b>	Controller sequence number of the last inbound sync-point message IMS received from the workstation
<b>Bytes 3, 4</b>	VTAM sequence number of the last outbound sync-point message IMS sent to the workstation



## Session Initiation (Starting Workstations)

IMS uses the action code to ask the SLU P system to verify the controller and VTAM sequence numbers. The bits of the action code byte are:

- Bits 0, 1**        Refer to the controller sequence-number field
- Bits 2, 3**        Refer to the VTAM sequence-number field
- Bits 4, 5, 6, and 7**  
                      Reserved

The following values are acceptable for bits 0, 1, 2, and 3 of the action code:

- 00 IGNORE**    Not used by IMS.
- 01 SET**        Set the appropriate sequence number to the value indicated in the sequence-number field.
- 10 INVALID**   Not used by IMS. The SLU P system must return its version of the sequence number in the command response.
- 11 SET AND TEST**  
                  Set the appropriate sequence number to the value indicated in the sequence-number field. The SLU P system must indicate in the command response whether the sequence number values are acceptable.

IMS uses the SET option for the controller sequence number. For the VTAM sequence number, IMS uses either SET or SET AND TEST. SET is used when no acknowledgment to a recoverable output message is outstanding from the previous session. SET is also used when the IMS master terminal operator enters the /DEQUEUE or /ASSIGN commands that cause the last recoverable message to be removed from the queue. SET AND TEST is used if IMS sends a recoverable message to the workstation but does not receive the required acknowledgment prior to session termination. The response sent by the SLU P system to the STSN command indicates whether the workstation received the message.

When the SLU P system receives the STSN command, it must be able to:

- Verify the controller sequence number and arrange to retransmit a message to IMS if required.
- Verify the VTAM sequence number and inform IMS whether the number is acceptable.
- Return a DR1 to IMS and, if required, return a 5-byte data response to the STSN command.

To verify the controller sequence number, the SLU P system compares the number provided by IMS with the number it maintained from the previous session. An equal compare indicates that IMS received all messages sent by the workstation. If the IMS-provided number is smaller, IMS did not receive the last inbound sync-point message sent by the workstation. These two numbers can differ by more than 1 if intervening irrecoverable or chained messages were sent by the workstation when the workstation was defined with the ACK option. A message that was not received by IMS should be retransmitted after message resynchronization is complete. If a copy of the message was maintained, that copy could be sent. Otherwise, the SLU P system can inform the workstation operator that the last inbound recoverable message was not received by IMS.

To verify the VTAM sequence number, the SLU P system compares the number provided by IMS with the number it maintained from the previous session. An

## Session Initiation (Starting Workstations)

equal compare indicates that the workstation has received all messages. If the IMS-provided number is unequal, the workstation did not receive the last outbound recoverable message.

The response to the STSN command indicates the results of the synchronization tests to IMS. The SLU P system must return a DR1 and, optionally, 5 bytes of data. If both the controller and VTAM sequence numbers are acceptable, only the DR1 is required. If one or both of the sequence numbers are not acceptable, a DR1 and the 5-byte data response are required. The format of the data response has the same format as the STSN command:

<b>Byte 0</b>	Action code
<b>Bytes 1, 2</b>	Controller sequence number of the last inbound recoverable message the workstation sent to IMS
<b>Bytes 2, 3</b>	VTAM sequence number of the last outbound recoverable message the workstation received from IMS

The SLU P system uses the action code to indicate the test results. The bits of the action code byte are:

<b>Bits 0, 1</b>	Refer to the controller sequence-number field
<b>Bits 2, 3</b>	Refer to the VTAM sequence-number field
<b>Bits 4, 5, 6, and 7</b>	Reserved

The following values are acceptable for bits 0, 1, 2, and 3 of the action code:

<b>00 RESET</b>	The sequence number in the command is unacceptable and should be reestablished at its previous value. This code should never be returned to IMS.
<b>01 TEST POSITIVE</b>	The sequence number in the command is acceptable. This code must be returned in response to the SET option. If the SET AND TEST option is specified and the SLU P system finds the sequence number acceptable, TEST POSITIVE should be returned.
<b>10 INVALID</b>	The SLU P system has detected an error in the sequence number.
<b>11 TEST NEGATIVE</b>	The SLU P system does not agree with the sequence number presented with the SET AND TEST option.

TEST POSITIVE is the only acceptable response to the SET option. TEST POSITIVE and TEST NEGATIVE are acceptable responses to the SET AND TEST option. INVALID should be used if the SLU P system detects a "should-not-occur" condition when comparing the sequence numbers. An example of this condition is a controller sequence number specified in the command that is higher than the application program's copy of the sequence number.

If IMS receives a TEST NEGATIVE response to the SET option, a RESET response, or an INVALID response, it terminates the session.

When returning any action code except TEST POSITIVE, the SLU P system should use the STSN response to return its version of the sequence numbers. The sequence numbers can be valuable information during problem determination and

## Session Initiation (Starting Workstations)

debugging. Any value can be returned, because IMS does not use the returned values. A TEST NEGATIVE response is all that is required to indicate that the sequence number is not acceptable.

When IMS receives the STSN response, it sends the start-data-traffic (SDT) command to the workstation. The SDT command allows normal message transmission to begin. If IMS receives a TEST NEGATIVE response to the SET AND TEST option, it sends the SDT command and retransmits the last recoverable message followed by any other available output. When IMS receives a TEST POSITIVE response to the SET AND TEST option, it sends the SDT command, dequeues the last recoverable message, and sends any other available output.

The contents of the STSN command as received from IMS and the resulting actions of the SLU P system and VTAM are summarized in Table 68.

Table 68. Set-and-Test-Sequence-Numbers (STSN) Summary

Action Code		Controller Sequence Number <sup>1</sup>	VTAM Sequence Number <sup>1</sup>	Remote System Action when STSN Received	VTAM Action when STSN Received
Remote System Number	VTAM Number				
01 set		Last inbound sync point message that IMS received		Set controller sequence number field to value indicated in STSN controller field.	Set VTAM value to value indicated in STSN controller field.
	01 set		Last outbound sync point message that IMS sends, and responded to by station.	Set host sequence number field to value indicated in VTAM field of STSN.	Set VTAM's last assigned value to value in VTAM field of STSN.
	11 set and test		Last recoverable message that IMS sends; no response from station received.	Set host sequence number field to value indicated in VTAM field of STSN.	Set VTAM's last assigned value to value in VTAM field of STSN.

**Note:**

1. The controller and VTAM sequence number fields can contain any value.

The valid SLU P system responses to the STSN command and the resulting IMS actions are summarized in Table 69.

Table 69. Set-and-Test-Sequence-Numbers (STSN) Response Summary

If Action Code Value Was:		Response Action Code Must Be <sup>1</sup> :		IMS Action when Response Received
Remote System Number	VTAM Number	Remote System Number	VTAM Number	
01 set		01 test positive		Send SDT to station
	01 set		01 test positive	Send SDT to station

## Session Initiation (Starting Workstations)

Table 69. Set-and-Test-Sequence-Numbers (STSN) Response Summary (continued)

If Action Code Value Was:		Response Action Code Must Be <sup>1</sup> :		
Remote System Number	VTAM Number	Remote System Number	VTAM Number	IMS Action when Response Received
	11 set and test		01 test positive	Dequeue last recoverable message and send SDT to station
	11 set and test		11 test negative	Send SDT to station and retransmit last recoverable message.

**Note:**

1. Any other response causes IMS to terminate the session.

## Suspending Output from IMS

If the controller application program does not want or cannot receive any more output from IMS, the program can send the VTAM quiesce-at-end-of-chain (QEC) command to IMS. IMS returns a DR1 and the VTAM quiesce-complete (QC) command. IMS does not send any more output to the workstation until it receives the VTAM release-quiesce (RELQ) command.

A workstation can also suspend output from IMS by sending the VTAM LUSTATUS or SIGNAL commands to IMS.

## Session Termination

**Definition:** *Session termination* releases the workstation from its current logical connection to the VTAM application program. It makes the workstation available for session with other VTAM applications, or communications can be terminated altogether.

There are two types of session termination: orderly and immediate.

**Definitions:**

- In an *orderly termination*, the workstation is allowed to complete normal processing before the session is terminated.
- An *immediate termination* forces the workstation to terminate the session unconditionally.

Session termination can be invoked by any of the following:

- The IMS master terminal operator
- The VTAM network operator
- The workstation

Figure 63 on page 471 summarizes the two types of session termination processing.

**Orderly Termination****Immediate Termination**

Figure 63. Termination Processing

Each installation must determine specific procedures for session termination. When developing the procedures, be aware of the requirements for session termination processing.

**Orderly Termination**

An orderly termination of the network is invoked by the IMS master terminal operator using the IMS /CHECKPOINT FREEZE, /CHECKPOINT PURGE, or /CHECKPOINT DUMPQ command with the QUIESCE parameter. QUIESCE is a /CHECKPOINT parameter that initiates shutdown processing for a network. When QUIESCE is specified, IMS sends the VTAM shutdown (SHUTD) command to all workstations and waits until all workstations have completed normal processing and returned the VTAM shutdown-complete (SHUTC) command.

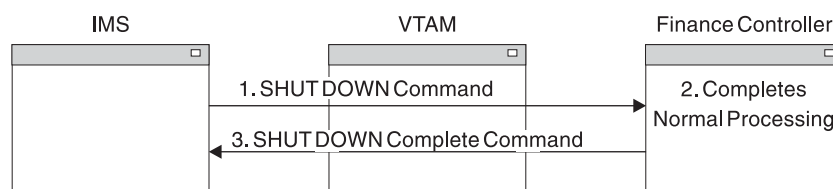
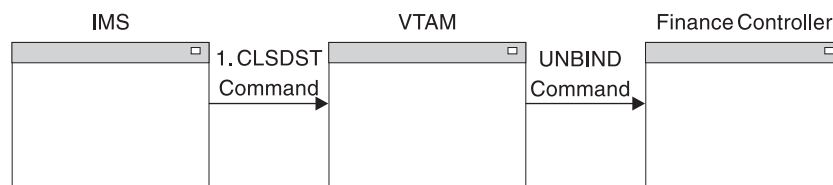
When all workstations have indicated that shutdown is complete, IMS performs checkpoint processing and then issues the VTAM CLSDST macro instruction. CLSDST causes VTAM to send the UNBIND command to all workstations. This command releases the workstations from session with IMS. The controller prohibits any further data transmission from the workstations.

During shutdown processing (the time between the VTAM shutdown-complete and CLEAR commands), the system's workstations should be prepared for any IMS output that results from shutdown processing.

During the processing of an orderly termination, the IMS master terminal operator can terminate the network unconditionally rather than wait for the orderly termination processing to complete. This can be done by invoking an immediate termination.

**Immediate Termination**

The IMS master terminal operator, the VTAM network operator, or the workstation user can invoke an immediate termination of a SLU P workstation.

The IMS master terminal operator uses the /CHECKPOINT command with the FREEZE, PURGE, or DUMPQ parameter, but without the QUIESCE parameter, to invoke

## Session Termination

immediate termination of the network. IMS issues the VTAM CLSDST macro instruction. CLSDST causes VTAM to issue the UNBIND command to all workstations. This command releases the workstation from session with IMS. The controller prohibits any further data transmission from the workstation.

To terminate workstations or portions of a network selectively, the IMS master terminal operator can use the IMS /CLSDST or /STOP command. /CLSDST and /STOP commands cause IMS to issue the VTAM CLSDST macro instruction for the specified workstations. The /STOP command also prevents further sessions from being established until a /START command is issued for the workstation.

The z/OS VTAM network operator uses the VARY command to terminate a workstation immediately. z/OS VTAM network operator intervention using the VARY command might be required to terminate sessions in which a workstation error prevents an I/O operation from completing.

The workstation uses VTAM session control commands to terminate a session with IMS. Under normal processing circumstances, when the workstation decides to terminate its session with IMS, that workstation should send the VTAM request-shutdown command. IMS completes any input or output currently in progress for that workstation and then issues the VTAM CLSDST macro instruction.

If the workstation detects an error condition from which it cannot recover and then wants to terminate the session, it can send the VTAM terminate-session command. VTAM releases the workstation from the session and notifies IMS accordingly.

---

## Shutting Down an IMS Network

Shutting down an IMS network may or may not include IMS.

The IMS /CHECKPOINT command is used to invoke termination of the network and a shutdown of IMS. The format of /CHECKPOINT used determines whether the network termination occurs immediately or waits for workstation processing to complete:

**/CHECKPOINT FREEZE|DUMPQ|PURGE QUIESCE**

Allows all workstations to complete normal processing before shutting down IMS.

**/CHECKPOINT FREEZE|DUMPQ|PURGE**

Causes immediate session termination for all workstations.

**Related Reading:** See “Immediate Termination” on page 471 if the network, or a portion of a network, requires shutdown without shutting down IMS.

---

## SLU P Messages

The primary function of IMS support for the SLU P system is to receive and transmit data for a workstation and to ensure that the data is processed properly. Input/output messages can consist of the following data types:

- IMS transactions
- IMS message switches
- IMS commands
- VTAM commands and indicators
- Message Format Service (MFS) control requests

IMS can process nongraphic characters when sending and receiving any of these messages.

**Related Reading:** For more information on how IMS processes nongraphic message data, see “IMS Sensitivity to Nongraphic Message Data” in *IMS Version 9: Administration Guide: System* .

---

## Send/Receive and Bracket Protocol

The change-direction indicator and bracket protocol, as defined by VTAM, are used to specify the beginning and end of synchronous transmissions and to control the flow of such transmissions. Because of its queued input and output processing, IMS does not support multiple related inputs or multiple related outputs. While in an in-brackets state, the following can occur:

- One input message (coded BB/EB)
- One output message (coded BB/EB)
- One input message and an output reply (input coded BB/CD and output coded EB)

The input message and output reply are related only for:

- Fast Path transactions
- Terminal-response mode transactions
- Conversational transactions

For other transaction types, the input message and output reply might or might not be related.

**Related Reading:** For more information on how IMS sends and receives the bracket and change-direction indicators, see “Input Bracketing Protocol” on page 478 and “Output Bracketing Protocol” on page 485.

## Send/Receive and Bracket Protocol



---

## Chapter 24. SLU P Message Protocols

### In this Chapter:

- “General Format of Input Function Management Headers (Finance)”
- “Input Message Descriptor Byte (Finance)” on page 476
- “General Format of Input Function Management Headers (SLU P)” on page 476
- “Output Messages” on page 479
- “MFS Distributed Presentation Management Output (SLU P)” on page 481
- “General Format of Output Function Management Headers (Finance)” on page 482
- “General Format of Output Function Management Headers (SLU P)” on page 483
- “Input Response Requirements” on page 486
- “Output Response Requirements” on page 487
- “IMS Transaction Types” on page 488
- “Error Handling” on page 490

A single transmission must be used for VTAM commands and indicators and MFS control requests. Single or multiple transmissions can be used to send IMS transactions, commands, and message switches. Multiple transmissions for one message are required if the workstation’s transmission buffer is not large enough to hold all of the data to be sent. Multiple transmissions can also be used if the workstation user wants to segment the data. Multiple transmissions are logically related through the concept of chained messages. Each transmission of a multiple transmission message is identified by its position in the chain—that is, first-in-chain, middle-in-chain, last-in-chain (see Figure 64 on page 480).

In a SLU P system using chained input messages, the chaining indicator is used to specify the chain position of the transmission; it should not be set for an unchained message. The chaining indicator must be turned on for the first-in-chain transmission, turned off for each middle-in-chain transmission, and turned on again for the last-in-chain transmission.

When MFS is defined, input messages can be processed by the MFS. For input formatting, MFS does not distinguish between possible input components but assumes that all input comes from the 4701/4702 application program.

---

### General Format of Input Function Management Headers (Finance)

IMS transactions, message switches, and commands are in the standard IMS format (transaction code, logical terminal name, or command verb, followed by a blank and text) unless MFS or a Physical Terminal Input edit routine is used to edit the message into the standard format. The first or only transmission of IMS transactions can have a variable-length FM header. If MFS is not defined for the workstation, the header is ignored. If MFS is defined, the header can contain either an MFS control request or a MID name. For MFS control requests, only the first 2 bytes of the FM header are required.

**Byte 0** Header length including the length byte (binary). Bytes 0 and 1 constitute an MFS control request.

## General Format of Input Function Management Headers (Finance)

<b>Byte 1</b>	Message description (binary).
<b>Byte 2</b>	MID name length (binary).
<b>Bytes 3-10</b>	MID name (1 to 8 bytes) (EBCDIC).

IMS uses the header, but removes it before sending the message to the MPP or MFS. When IMS receives a message with a header, it interrogates the length of the message. If the message length is 2 bytes, IMS assumes that the message is an MFS control request. The MFS control request is indicated in the message description (byte 1).

**Related Reading:** For more information on using the PAGEREQ function, see *IMS Version 9: Application Programming: Transaction Manager*.

---

## Input Message Descriptor Byte (Finance)

If the message length is more than 2 bytes, IMS interrogates the message description to determine whether an MFS MID name is present. The format description specified by the MID name is used to format the message.

The format of the message descriptor byte is:

<b>Bit 0</b>	Reserved
<b>Bit 1</b>	Page advance requested (NEXTTPP)
<b>Bit 2</b>	Message advance requested (NEXTMSG)
<b>Bit 3</b>	Message advance protect requested (NEXTMSGP)
<b>Bit 4</b>	Next logical page requested (NEXTLP)
<b>Bit 5</b>	Reserved
<b>Bit 6</b>	Format description that is indicated by the MID name length and MID name fields should be used to format this input message.
<b>Bit 7</b>	Reserved

Bits 1, 2, 3, and 4 (MFS control requests) are mutually exclusive and are examined only if the message length is 2 bytes. Bit 6 must be set on if the input message is to be formatted by an MFS MID name. If bit 6 indicates an MFS MID name is present, bits 0 through 5 must be zero.

---

## General Format of Input Function Management Headers (SLU P)

IMS transactions, message switches, and commands are in the standard IMS format (transaction code, logical terminal name, or command verb, followed by a blank and text). If a message is in nonstandard format, MFS or a Physical Terminal Input edit routine can be used to edit the message into the standard format. The first or only transmission of IMS transactions can have a variable-length FM header. If MFS is not defined for the terminal, the header is ignored. If MFS is defined, the header can contain either an MFS control request or optional MFS fields used to invoke MFS formatting. IMS uses the header in these cases, but removes it before passing the message on to the MPP or MFS. Incorrect header specifications or formats can cause the session to terminate. SLU P uses header type X'42'.

The format of the input FM header is:

<b>Byte 0</b>	Header length including the length byte in binary (first byte)
---------------	--

## General Format of Input Function Management Headers (SLU P)

<b>Byte 1</b>	Header type (must be X'42')
<b>Byte 2</b>	Message descriptor 1 (flag byte is binary)
<b>Byte 3</b>	Message descriptor 2 (flag byte is binary)
<b>Byte 4</b>	Input component identification (binary)

Optional MFS fields:

### For DPM:

<b>Bytes 5 and 6</b>	Version ID (in binary) if bit 0 of byte 3 is on.
<b>Bytes 7-15</b>	MID name length, including length byte (1 byte), followed by the MID name (1 to 8 bytes). If bit 0 of byte 3 is off (version ID not included in the FM header), the MID name length and the MID name are in bytes 5 through 13.

### For SCS:

<b>Bytes 3-13</b>	MID name length (in binary), including length byte (1 byte), followed by the MID name (1 to 8 bytes).
-------------------	---

**Related Reading:** For more information on the Version ID field, see *IMS Version 9: Application Programming: Transaction Manager*.

When IMS receives a message with a header, it determines the length of the message. If the message length is 5 bytes, IMS assumes that the message is an MFS control request. The specific MFS control request is indicated in message descriptor 1 (byte 2). If the message length is more than 5 bytes, IMS examines the message description bytes to determine whether an MFS version ID and a MID name are present. When both are present, the version ID must immediately precede the MID name length. (Version ID does not exist for SCS1.) The format description specified by the MID name is used to format the accompanying input message, and the version ID is used to validate the format description level. If no FM header is provided, no version ID is provided, or a version ID of zero is provided, MFS bypasses the validity check on the format description level.

## Input Message Descriptor Bytes (SLU P)

Message descriptor 1 (byte 2 of the FM header) has the following format:

<b>Bit 0</b>	Reserved
<b>Bit 1</b>	Page advance requested (NEXTTPP)
<b>Bit 2</b>	Message advance requested (NEXTMSG)
<b>Bit 3</b>	Message advance protect requested (NEXTMSGP)
<b>Bit 4</b>	Next logical page requested (NEXTLP)
<b>Bit 5</b>	Reserved
<b>Bit 6</b>	Format description indicated by the MID name length, and MID name fields should be used to format this input message
<b>Bit 7</b>	Reserved

Bits 1, 2, 3, and 4 (MFS control requests) are mutually exclusive. Bit 6 must be set on if the input message is to be formatted by the MFS MID name provided. When bit 6 indicates a MID name is present, bits 0 through 5 must be zero.

## General Format of Input Function Management Headers (SLU P)

Message descriptor 2 (byte 3 of the FM header) has the following format:

<b>Bit 0</b>	Version identifier for MFS DPM. Bit 0 must be set on if bytes 5 and 6 of the FM header contain the version ID.
<b>Bit 1-7</b>	Reserved

## Input Component Identification (SLU P)

The input component identification is used for the input component selected, as previously described in “Component Definition” on page 445. The component identification can be a value between 0 and 4, matching the ICOMP specified on the NAME macro during IMS system definition or on an ETO user descriptor.

**Related Reading:** For more information on the ETO feature, see Chapter 9, “Administering the Extended Terminal Option,” on page 147.

If a component identification is zero, or if no FM header is sent, the input is associated with component 1. Further, IMS uses the input component identification to reset component output protection. If a value of 0 (zero) is sent, output protection is reset on all components of the terminal. If a value 1 through 4 is sent, output protection is reset on only the specified component.

## Input Bracketing Protocol

A workstation in session with IMS must indicate begin-bracket (BB) or both begin-bracket and end-bracket (EB) on each of following:

- The first transmission of a chained message (multiple transmission)
- Each transmission of unchained messages

The end-bracket indicator places both IMS and the workstation between brackets and in a contention state. If only the begin-bracket indicator is sent, the workstation should send a change-direction (CD) indicator on each of the following:

- The last transmission of a chained message (multiple transmission)
- Each transmission of unchained messages

The CD indicator is necessary, because IMS cannot correlate multiple input messages. The CD indicator is implied if it is not specified.

If BB and CD are indicated, IMS indicates EB on its next output to the workstation. If IMS detects an error while receiving chained input on which only BB is specified, it returns an EB and an IMS error message.

**Related Reading:**

- For more information on output messages, see “Output Messages” on page 479.
- For more information on error handling, see “Error Handling” on page 490.

**Restriction:** For SLU P terminals, a CD or EB indicator must accompany each input chain; otherwise, the session terminates.

## Activating MFS Input Formatting for Finance Workstations

When MFS is used, input messages can be processed by the message and format descriptors. When IMS receives an input message, IMS Basic Edit is performed unless a MID name accompanies the message. The MID name can be supplied by including it either in the input function management header or in the beginning of

## General Format of Input Function Management Headers (SLU P)

the message text with the required MFS escape characters (//). When the MID name is present, MFS edits the message using the specified MID and its associated device input format (DIF). The MID name is provided by either the operator or the remote application program.

---

### Output Messages

Output messages from IMS can be one of the following types:

- Data replies to recoverable or irrecoverable input transactions
- Data replies to IMS commands
- Message switches
- VTAM indicators
- IMS system messages
- Broadcast messages
- A null (length=0) message containing end-bracket to return the workstation to between-brackets and to a contention state

All messages from IMS to a workstation are sent in a single transmission unless:

- The MPP, a message switch, a command, or MFS provides a multi-segment output message.
- The workstation's read buffer is too small to hold the single-segment output message provided by the MPP or MFS.
- A broadcast message is multi segment.

Each segment of a message is sent in a single transmission whenever possible, that is, when only-in-chain is indicated. However, if a message segment exceeds the size of the receiving workstation read buffer, the segment is divided into as many transmissions as required until the complete segment is sent. Multi segment output messages are handled like chained input messages: Each segment is identified appropriately as first-in-chain, middle-in-chain, or last-in-chain.

Exercise care when defining the sizes for IMS message queue data sets and workstation output buffers. Incorrect specification can result in multi segment output chains from IMS. Output buffer sizes that are too small can result in multiple transmissions for large IMS segments. Message queue data set sizes that are too small can result in multiple IMS segments being created for large message processing program (MPP) inserts.

**Related Reading:** For information on the MSGQUEUE and TERMINAL macros, see *IMS Version 9: Installation Volume 2: System Definition and Tailoring*.

**Definition:** *MFS-paged output* is each physical page of a message destined for a display device and sent as if it were a complete message.

Figure 64 on page 480 shows the relationship between transmissions sent to IMS, segments produced by the MPP, and segments transmitted by IMS.

# Output Messages

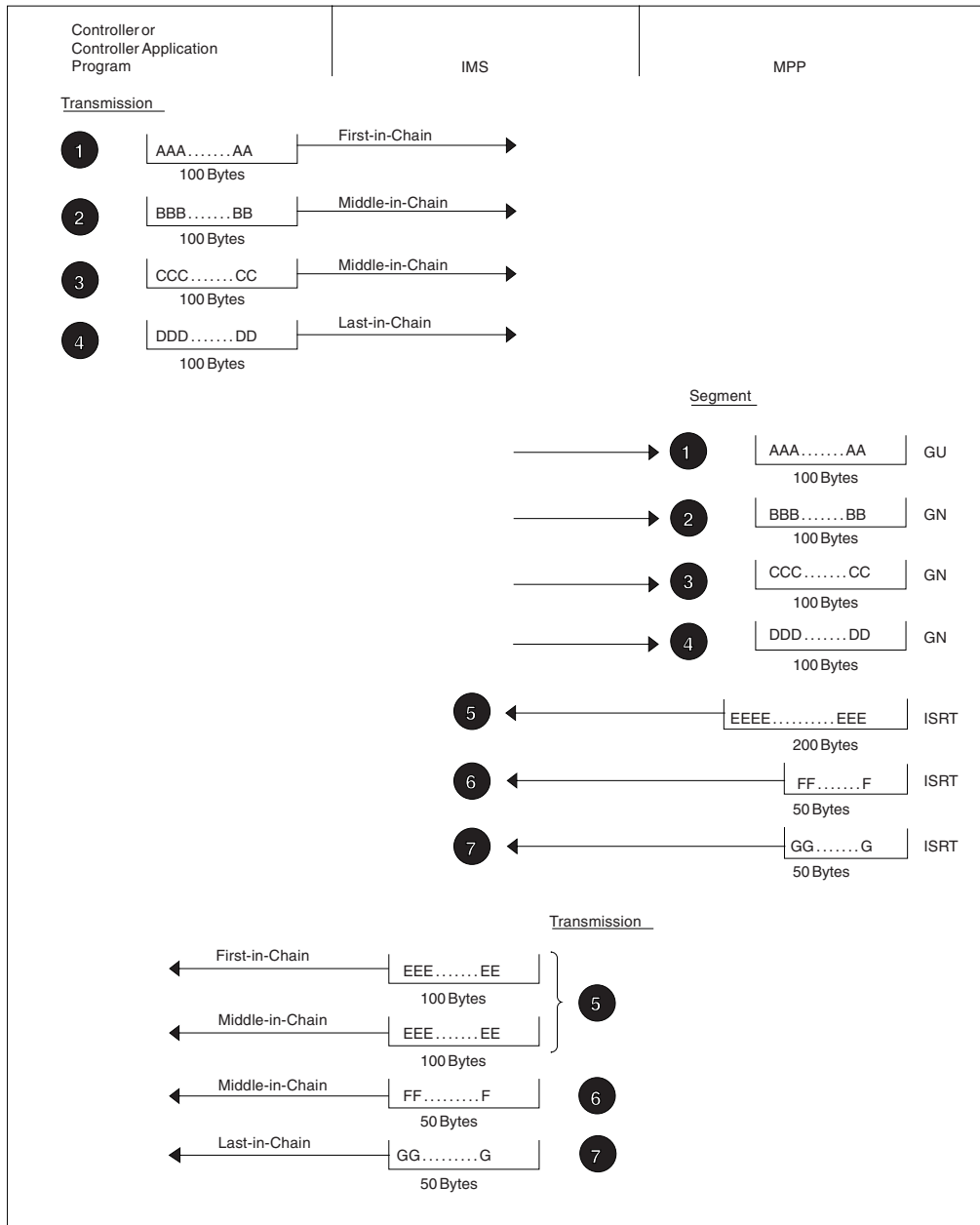

Figure 64. Chained Message Interaction between a Finance Communication System and an IMS MPP

After successfully receiving a message, the SLU P system must interrogate the read-type field (SMSCRT), the read-flags field (SMSCRF), and, optionally, the read-flags field extension (SMSCRE) to determine the type and characteristics of the message received.

**Related Reading:** For more information on these fields, see *IBM 4700 Finance Communication System: Controller Programming Library, Volume 3: Communication Program*.

If a non-MFS-formatted output segment is sent in multiple transmissions and the SCAN option is defined for that workstation, IMS does not allow a 4701/4702 device's select control, position-control, or write-control sequence to be split across transmissions. When transparent write-control sequences are split into two

transmissions, the data length on the first transmission is modified, and the proper write control characters are inserted at the beginning of the second transmission.

Editing for device control sequences does not occur for non-MFS-formatted output if the NOSCAN option is specified during IMS system definition or on an ETO logon descriptor. If MFS formats the output segment, the device-control sequence (select and position) editing always occurs. Each transmission of the segment, except the last, ends in a three-character, null-horizontal-position sequence to suppress the automatic new-line function of the physical SLU P system output device.

---

### MFS Distributed Presentation Management Output (SLU P)

IMS sends the entire output message as a single chain of one or more related transmissions. For MFS DPM output using a device format defined with paging `OPTIONS=DPAGE` or `OPTIONS=PPAGE`, IMS sends each logical or presentation page in a single chain of one or more related transmissions as if it were a complete message.

For MFS DPM output using a device format defined with paging `OPTIONS=DPAGE` or `OPTIONS=PPAGE`, IMS sends an output function management header as part of the first or only transmission of each chain (logical or presentation page) of the message. The remainder of the transmission contains data fields (DFLDs) up to the defined record length. This function management header contains the DPM version ID, `DPAGE` or `PPAGE` name, and a MID name if specified.

When a forms literal is defined in the DPM format specification for paging `OPTIONS=DPAGE` or `OPTIONS=PPAGE` (`FORMS=` parameter on the DEV statement), IMS precedes the first logical or presentation page with an only-in-chain transmission consisting of a function management header containing only the forms literal. No version ID, `DPAGE` name, or `PPAGE` name is provided. Output components are protected at the end of each output chain; this prevents IMS from sending subsequent output, or logical or presentation pages (chains), until an appropriate input message or control request is received.

For MFS DPM output using a device format defined with paging `OPTIONS=MSG`, IMS sends the entire message as a single chain of one or more related transmissions. The function management header is sent as the first or only transmission and contains the DPM version ID, format name, and any MID name or forms literal defined in the MFS format specification. In this case, as for non-DPM output, component protection is provided only if the destination component is defined as `PROGRAM2`.

For DPM, the device type symbolic name is specified to MFS as `DPM-Xn`, where X can be A or B. Message formatting is specified on the `TERMINAL` macro or on an ETO logon descriptor for logical units defined as SLU P by using device type symbolic names of the form `DPM-An`. `DPM-Bn` device type symbolic names refer to logical units defined for Intersystem Communication.

---

### General Format of Output Function Management Headers (Finance)

IMS appends a header to the first or only-in-chain transmission of all messages sent, except the IMS null message and VTAM commands and indicators. This header describes the type of message that follows and, if appropriate, indicates the output component that is to receive the message. The header can contain optional MFS information.

The length of the output function management header varies from 3 to 29 bytes. The format is:

<b>Byte 0</b>	Header length including length byte (binary)
<b>Byte 1</b>	Message description (binary)
<b>Byte 2</b>	Output component identification (binary)
<b>Bytes 3-28</b>	MFS data (length byte: binary; names: EBCDIC)

### Output Message Descriptor Byte (Finance)

The bits of the message descriptor byte (byte 1), when set on, have the following meanings:

<b>Bit 0</b>	This message is an IMS system message or a broadcast message.
<b>Bit 1</b>	This message is formatted by MFS.
<b>Bit 2</b>	An MFS system control area (SCA) has requested device alarm for this message. (The controller application program can take any appropriate action, such as turning on a terminal's light.)
<b>Bit 3</b>	This message is a nonqueued message (no specific destination). Bit 0 is also set.
<b>Bit 4</b>	Reserved.
<b>Bit 5</b>	This message is Fast Path-recoverable output.
<b>Bit 6</b>	A MID name is present in the MFS data field.
<b>Bit 7</b>	A FORMS name is present in the MFS data field.

### Output Component ID Byte (Finance)

The output component identification (byte 2) contains a value from X'01' to X'04'. This value identifies the terminal component to which this message is directed. Output component identifiers are assigned during IMS system definition, on an ETO user descriptor, or by using the Signon (DFSSGNX0) and the Output Creation (DFSINSX0) exit routines. These identifiers are specified by the sender of the message (either IMS or the message processing program).

**Related Reading:** For more information on the output component identification, see "Output Component Selection" on page 446.

### MFS Data Bytes (Finance)

Bytes 3 through the end of the header can contain MFS data, and one or two fields can be present. Bits 6 and 7 of the message descriptor byte indicate whether these fields are included. The first field, if present, is 2 to 9 bytes long and contains a 1-byte length indicator including length byte and a 1- to 8-byte MFS MID name. This MID name field is present if the message output description contains the name of the MID to be used for the next input message, and should be returned to



## General Format of Output Function Management Headers (Finance)

IMS by the controller program. The second field, if present, is 2 to 17 bytes long and contains a 1-byte length indicator including length byte and a 1- to 16-byte FORMS name. FORMS name identifies the special form required for this message. Before printing the message, the application program should ensure that the form is in place and that page size and forms alignment are established.

---

## General Format of Output Function Management Headers (SLU P)

IMS appends a header to the first or only-in-chain transmission of all messages sent, except the IMS null message and VTAM commands and indicators. This header describes the type of message that follows and, if appropriate, indicates the output component that is to receive the message. The header can also contain optional MFS information. SLU P uses header type X'42'.

The length of the output function management header varies from 5 to 42 bytes. The format is:

<b>Byte 0</b>	Message header length including length byte (binary)
<b>Byte 1</b>	Header type (X'42')
<b>Byte 2</b>	Message descriptor 1 (flag byte is binary)
<b>Byte 3</b>	Message descriptor 2 (flag byte is binary)
<b>Byte 4</b>	Output component identification (binary)
<b>Bytes 5-41</b>	MFS data (length byte: binary; names: EBCDIC)

**Related Reading:** For information on MFS data, see “MFS Data Bytes (SLU P)” on page 484.

## Output Message Descriptor Bytes (SLU P)

The bits of the message descriptor 1 (byte 2) have the following meaning when set on:

<b>Bit 0</b>	This message is an IMS system message or a broadcast message.
<b>Bit 1</b>	This message is formatted by MFS.
<b>Bit 2</b>	Reserved.
<b>Bit 3</b>	This message is a nonqueued message (no specific destination). Bit 0 is also set.
<b>Bit 4</b>	Reserved.
<b>Bit 5</b>	Fast Path-recoverable output.
<b>Bit 6</b>	A MID name is present in the MFS data field.
<b>Bit 7</b>	A forms name is present in the MFS data field.

The bits of message descriptor 2 (byte 3), when set on, have the following meaning:

<b>Bit 0</b>	This output is formatted by MFS DPM. The version ID might or might not be present, and one of the following is present in the MFS data field: <ul style="list-style-type: none"><li>• DPM format name</li><li>• Logical page name (DPAGE statement label)</li><li>• Presentation name (PPAGE statement label)</li></ul>
--------------	---

## General Format of Output Function Management Headers (SLU P)

<b>Bit 1</b>	Reserved.
<b>Bit 2</b>	At the end of this chain, the component indicated in byte 4 of the output function management header is protected.
<b>Bits 3-7</b>	Reserved.

If message descriptor 2, bit 2, is set on, IMS does not send another output chain until an appropriate input occurs. This input can be an input message, an MFS control request, or a READY-TO-RECEIVE (RTR) command.

**Related Reading:** For more information on extended output component protection, see "Extended Output Component Protection (SLU P)" on page 453.

## MFS Data Bytes (SLU P)

Bytes 5 through the end of the header can contain up to four MFS fields, depending on settings in message descriptor 1, bits 6 and 7, and message descriptor 2, bit 0.

If bit 0 is on, the first field, if present, is a 2-byte MFS DPM version identification. This field is present for all MFS DPM formatted output. The field can contain a version ID, or the value 0 (zero). In either case, one of the following fields (second, third, or fourth field) is present.

The second field, if present, is 2 to 9 bytes long and contains a 1-byte length indicator, including length byte followed by a 1- to 8-byte MFS MID name. This MID name field is present if the message output description contains the name of the MID to be used for the next input message, and should be returned to IMS by the controller program.

The third field, if present, is 2 to 9 bytes of data name, as defined by the paging option for the MFS device format.

The fourth field, if present, is 2 to 17 bytes long and contains a 1-byte length indicator, including length byte followed by a 1- to 16-byte user-specified MFS forms literal. The forms literal identifies the special setup or forms required for this message. The user must define the procedure to be followed at the terminal upon receipt of the forms literal.

The message format name (FMT statement label) is present if OPTIONS=MSG is specified; the logical page name (DPAGE statement label) is present if OPTIONS=DPAGE is specified; the presentation page name (PPAGE statement label) is present if OPTIONS=PPAGE is specified. This field appears in all output (message descriptor 2, bit 0) from DPM.

The content and format of the function management header for DPM formatted output can be influenced when defining the MFS device format through the HDRCTL=FIXED or HDRCTL=VARIABLE option. If HDRCTL=VARIABLE is specified, each MFS header field is variable in size. If HDRCTL=FIXED is specified, the following MFS header fields are sent and padded to their maximum size.

- The MID name field in the output header is padded with trailing blanks for the maximum length of 8 bytes. Eight blanks are sent if no MID name is specified to format the next input through the user-supplied message output description.
- The message format name is padded to a maximum length of 6 bytes. The logical page name or the presentation page name is padded to a maximum length of 8 bytes.

### Output Bracketing Protocol

For output messages, IMS specifies begin-bracket and end-bracket on single-segment output messages and on the first transmission of a multi segment message. If the input message specified begin-bracket and change-direction, the next output IMS sends specifies only end-bracket. If IMS detects an error when receiving chained input on which only begin-bracket is specified, it returns end-bracket and an IMS error message.

**Related Reading:** For more information on error handling, see “Error Handling” on page 490.

In the case of Fast Path, conversational, or response-mode transactions, the output message is the reply to the previous input message. In other cases, the output message might or might not be related to the previous input message.

IMS sends an only-in-chain output message (no FM header and data length=0), requesting exception DR2, and indicating FM header end-bracket when no other output is immediately available. This occurs in the following situations:

- An input message from a workstation defined to IMS as “negated terminal-response mode” specifies begin-bracket and change-direction.
- An input message from a workstation defined to IMS as “forced terminal-response mode” specifies begin-bracket and change-direction and is not an IMS transaction.
- An input message from a workstation defined to IMS as “transaction-dependent terminal-response mode” specifies begin-bracket and change-direction and is not a response-mode transaction.

After receiving exception-response sense codes 0811 and 0812, IMS also sends an only-in-chain output message (no FM header and data length=0), requesting exception DR2, and indicating FM header begin-bracket/end-bracket when no other output is immediately available.

### Activating MFS Output Formatting

MFS output formatting occurs when an output message has an associated message output descriptor (MOD). This occurs when any of the following occurs:

- The MPP supplies the name of a MOD (MOD name) with the output message.
- The input message was processed by a message input descriptor (MID) whose definition specified a MOD name for output formatting.
- The output message is a message switch from a device using MFS editing.

If no MOD is associated with the output message, standard IMS output editing occurs.

Input formatting for a workstation only occurs when a MID name and the message itself are sent to IMS. Specifying the next MID name is allowed in the message output description. Controller involvement is required to assure the proper MID is used, because IMS cannot directly control the receipt of input. Therefore, while IMS is formatting an output message, the workstation can be sending an input message. Input sent while IMS is processing output is queued by VTAM until IMS completes output processing. If the next MID name is specified, the input queued by VTAM appears as if it were the result of the current output. Unpredictable results occur if the internal MID name is used to format the message. IMS avoids this by sending the MID name as part of the input message.

## General Format of Output Function Management Headers (SLU P)

IMS informs the controller that the name of the next MID is specified, and sends the MID name requested and the output message to the workstation. The controller then saves the MID name, displays the output message, reads the next operator input, adds the saved MID name to the transaction, and sends the transaction to IMS.

### Response Requests (Finance)

Output messages from IMS require specific responses. IMS commands, broadcast output, message switches, and non-Fast Path transactions defined to IMS as update-inquiry or recoverable-inquiry require a DR2, except replies to all but the last physical or logical page of non-operator, logical-paged MFS output.

**Related Reading:** For information on response requirements, see “Input Response Requirements.”

Transactions defined to IMS as irrecoverable-inquiry or replies to operator logical-paged MFS output require an exception DR2. Except for the last physical page of a message whose MOD does not specify PAGE=YES, MFS-paged output requests an exception DR2 reply (regardless of how the transaction is defined), because an explicit MFS control or data input must follow each page before another page of output is allowed; otherwise, the message is dequeued.

Fast Path output messages are sent requesting an exception DR2 response regardless of the transaction type. The next input message from the workstation or an RTR command provides acknowledgment that the preceding output has been received and that IMS might dequeue the message.

### Response Requests (SLU P)

Except for replies to all but the last physical or logical page of non-operator, logical-paged MFS output, output messages from IMS require specific responses. IMS commands, broadcast output, message switches, and non-Fast Path transactions defined to IMS as update-inquiry or recoverable-inquiry require a DR2.

**Related Reading:** For information on response requirements, see “Input Response Requirements.”

Because an explicit MFS control or data input must follow each page before another page of output is allowed (or the message is dequeued), transactions defined to IMS as irrecoverable-inquiry and replies to operator logical-paged MFS output require an exception DR2. MFS-paged output, except the last physical page of a message whose MOD does not specify PAGE=YES, requests an exception DR2 reply regardless of how the transaction is defined.

---

## Input Response Requirements

Table 70 summarizes input requirements for requesting responses for all types of data transmission between a workstation and IMS.

*Table 70. Input Response Requirements by Message Type*

Data Type	Responses Accepted (ACK Option)	Responses Accepted (OPTACK Option)
Update transaction	DR2 <sup>1</sup> Exception DR1 or exception DR2 <sup>3</sup>	DR1 or DR2 Exception DR1 or exception DR2 <sup>1, 2</sup>

Table 70. Input Response Requirements by Message Type (continued)

Data Type	Responses Accepted (ACK Option)		Responses Accepted (OPTACK Option)	
	Recoverable-inquiry transaction	DR2 <sup>1</sup> Exception DR1 or exception DR2 <sup>3</sup>	DR1 or DR2 Exception DR1 or exception DR2 <sup>1, 2</sup>	DR1 or DR2 Exception DR1 or exception DR2 <sup>1, 2</sup>
Irrecoverable-inquiry transaction	DR1 or DR2 or DR2 <sup>1</sup>	Exception DR1	DR1 or DR2 Exception DR1 or exception DR2 <sup>1, 2</sup>	Exception DR1
Fast Path transaction <sup>4</sup>	N/A		DR1 or DR2 Exception DR1 or exception DR2 <sup>1, 2</sup>	Exception DR1
IMS message switch	DR2 <sup>1</sup>		DR1 or DR2 Exception DR1 or exception DR2 <sup>1, 2</sup>	Exception DR1
IMS command	DR1 or DR2 or DR2 <sup>1</sup>	Exception DR1	DR1 or DR2 Exception DR1 or exception DR2 <sup>1, 5</sup>	Exception DR1
VTAM command or indicator	DR1 <sup>1</sup>		DR1 <sup>1</sup>	
SLU P system MFS control request	DR1 or DR2 or DR2 <sup>1</sup>	Exception DR1	DR1 or DR2 or DR2 <sup>1</sup>	Exception DR1

**Notes:**

1. Recommended or required response.
2. Fast Path users should always use OPTACK option with exception DRx.
3. With CD only for the commands /DIS, /RDIS, and /FOR.
4. ETO users should always use OPTACK option.
5. With Change Direction (CD) only.

## Output Response Requirements

Table 71 summarizes the response to be requested by IMS for all types of output messages.

Table 71. Output Response Requested by Message Type

Output Data Type	Response Requested
Update, Recovery	DR2
Inquiry, Recovery	DR2
Inquiry, Irrecovery	Exception DR1 and DR1 <sup>3</sup>
Fast Path (Recovery)	Exception DR2 <sup>1</sup> and DR2 <sup>2</sup>
Last MFS Page (when PAGE=YES is not specified on the MOD)	Refer to above output data types for response request
Nonlast MFS Page (or all pages when PAGE=YES is specified on the MOD)	Exception DR2 and DR2 <sup>2</sup>
IMS Command Replies: /FORMAT, /DISPLAY, /RDISPLAY	DR2
Other Commands	Exception DR2 and DR2 <sup>2</sup>
Test Mode Output	Exception DR1 and DR1 <sup>3</sup>
Broadcast or Message Switch Output	DR2

## Output Response Requirements

Table 71. Output Response Requested by Message Type (continued)

Output Data Type	Response Requested
<b>Notes:</b>	
1. Next input message or RTR provides acknowledgment if exception DR2 is requested.	
2. DR2 is requested when one of the following occurs:	
<ul style="list-style-type: none"><li>• The message is sent with BB (bidding with data).</li><li>• Messages on the IMS message queues are waiting to be sent to the workstation.</li><li>• The NFPACK option is defined on the system definition TERMINAL macro or on an ETO logon descriptor.</li></ul>	
3. DR1 is requested when the message is sent with BB (bidding with data).	

## IMS Transaction Types

Transactions are the most common data type sent from a workstation to IMS. IMS supports two kinds of transactions—update and inquiry. An update transaction can modify a database. An inquiry transaction can look at data in a database but cannot change or update it. Transactions are defined as update or inquiry during IMS system definition.

An additional attribute is defined for inquiry transactions—recoverable or irrecoverable. Recoverable-inquiry transactions are always recoverable no matter which element in the network fails. Irrecoverable-inquiry transactions are not recovered following an I/O error condition or IMS system restart.

All update transactions are recoverable.

All Fast Path transactions must be defined as recoverable, but can be either inquiry or update.

A workstation can be defined to handle one or both types of transactions. Other decisions and processing might be required of the controller or controller application program when both recoverable and irrecoverable transactions are handled. The decision to define a transaction as recoverable or irrecoverable requires an evaluation of the advantages and disadvantages that each transaction type offers to the individual operating environment.

The subtopics of this topic describe the inquiry message types and the responses required for each.

### Recoverable-Inquiry Transactions

To ensure that a recoverable transaction can be recovered, the workstation must:

- Request a DR1 or DR2 on input to IMS, or, if the OPTACK option is defined, optionally request an exception DR1 or exception DR2 and specify begin-bracket and change-direction on input to IMS.
- Maintain the input message sequence number, and, optionally, a copy of the input message until the DR1 or DR2 is returned, or, if the OPTACK option is specified, until a reply message containing an end-bracket is returned.
- Return any DR2 requested by IMS, or, if Fast Path, ensure that another input message or RTR command is sent after having accepted responsibility for an IMS output message by either logging or writing out the data.

To ensure that a recoverable transaction can be recovered, IMS:

- Requests a DR2 response, or, if Fast Path output and no output messages are waiting to be sent, requests exception DR2 and waits for subsequent data or RTR as acknowledgment of the output.
- Maintains the message sequence number and a copy of the message until a DR2, input data, or RTR, if Fast Path, is returned.
- Returns any requested DR1 or DR2 after having accepted responsibility for the message by either logging or writing out the data.

If a failure occurs between the sending of a recoverable message and receipt of the acknowledgment or reply message, the sender cannot determine whether the message reached its destination. During the restart procedure, IMS uses the VTAM STSN command to inform the controller of the sequence numbers of the last inbound sync-point message IMS received and of the last outbound sync-point message IMS sent. Any messages that have not been received can then be retransmitted.

When recoverable messages are being sent, only one recoverable message can be outstanding at a time. This means that the sender should send one message and wait for the response or reply before sending another. IMS reads a message, places the message on the input queue, and returns the DR1 or DR2 response or reply before it accepts another message.

### Irrecoverable-Inquiry Transactions

IMS treats an irrecoverable transaction in the same manner as a recoverable transaction, except that all processing required to achieve recoverability is eliminated. As a result, irrecoverable transactions require less processing time but can be lost in the event of a failure (for example, line failure, processor failure, queue failure) in the network.

An irrecoverable transaction need not request a DR1 or DR2. Because recoverability is not guaranteed, the receiver of the message is not required to acknowledge receipt. An irrecoverable transaction should, however, request an exception DR1 or DR2. The exception DR1 or DR2 requires fewer line transmissions than DR1 or DR2, because under normal circumstances no response is returned.

### Verifying IMS Receipt of Irrecoverable Messages

The SLU P system does not request that IMS acknowledge receipt of irrecoverable messages. However, if the system is transmitting multiple irrecoverable messages, indicating both begin-bracket and end-bracket, and wants to verify their receipt, it can send the VTAM CHASE command. VTAM indicators must request a DR1. When the SLU P system receives the normal definite response 1, all messages preceding the CHASE command have been received by IMS.

### IMS Message Switches

Because IMS treats a message switch that is sent or received just like a recoverable transaction:

- A message switch must request a DR1 or DR2 if the workstation is defined with the ACK option. If the OPTACK option is specified, a message switch optionally requests an exception DR1 or DR2 and should specify begin-bracket and change-direction on input to IMS.
- A message switch is recovered by IMS.
- The sequence number of a message switch is used in message resynchronization.

### IMS Commands

The network system analyst decides whether a workstation is allowed to enter IMS commands and, if so, which commands are allowed. IMS does not require that the controller request a specific response when sending an IMS command. DR1, DR2, and exceptions DR1 and DR2 are allowed; exception DR1 or DR2 is recommended.

IMS processes its commands and returns an IMS message when it finishes processing the command. Therefore, when a DR1 or DR2 is requested, IMS returns the DR1 or DR2, followed immediately by the message confirming command completion.

The additional line transmission required to send either the DR1 or DR2 and the command completion message can be eliminated if the controller requests exception DR1 or DR2.

If exception DR1 or DR2 is requested, the command completion message acknowledges receipt of the command and indicates that command processing is complete. If the ACK option is defined for the workstation, the VTAM sequence number of the command does not participate in message resynchronization as it does when only DR1 or DR2 is requested. If the OPTACK option is defined, all input participates in message resynchronization.

### VTAM Commands and Indicators

When a VTAM command is sent to IMS, a DR1 must be requested.

When IMS sends a VTAM command, it requests a DR1. If the BIND or BID command is sent, the response must be either a DR1 or exception DR1. If the STSN command is sent, a DR1 is required.

The controller responds to all other VTAM commands and indicators for the workstation.

### MFS Control Requests

When Message Format Service (MFS) is used, MFS control requests can be used to display paged messages and to control the display component screen. (The control request is specified in the input function management header.) DR1, DR2, or exception DR1 and DR2 can be requested. Using exception DR1 or DR2 is recommended, because the additional line transmission required to send DR1 or DR2 and the completion message can be eliminated if the controller requests exception DR1 or DR2.

---

## Error Handling

These topics describe the procedures used by IMS and required of the controller or the controller application program to handle failures resulting from transmission or protocol errors.

### IMS-Detected Errors

Whenever IMS detects an abnormal send or receive condition from VTAM, NCP, or the controller, it terminates the session. When an error on a received message is detected, IMS protects any display component and returns an exception DR1 or DR2 that includes 4 bytes of sense information:

**Bytes 0, 1**      System sense field



Bytes 2, 3      User sense field

### System Sense Field (SSENSE)

Bytes 0 and 1 contain one of the following values:

- X'0800'**      The user sense field contains the user message from the user message table.
- X'0819'**      The user sense field contains the IMS message number 290 (in binary). No output is available. This value is set only for a non-MFS response to a previously received RTR command.
- X'0826'**      The user sense field contains the IMS message number.

### User Sense Field (USENSE)

IMS uses the user sense field to pass on the number (converted to binary) of the appropriate error message. For example, an invalid transaction code generates the message:

```
DFS064 DESTINATION CANNOT BE FOUND OR CREATED
```

If IMS receives an invalid transaction code, it returns an exception DR1 or DR2 response with X'0040' in the user sense field.

In the XRF complex, the alternate system sends SSENSE=X'0826', USENSE X'0F15', and a DFS38611 SYSTEM TAKEOVER OCCURRED message if an input transaction is lost across the XRF session takeover. You must then retransmit the last input record.

**Related Reading:** For more information on responding to error messages transmitted during a system takeover, see "Writing the Controller Application Program for XRF Systems" on page 438.

IMS binds each session with unconditional bracket termination. When IMS sends an exception DR1 or DR2 to input, it must remain in a send state (regardless of the current bracket state), and the workstation must go to a receive state. Both IMS and the workstation must go to a between-brackets state if the input message in error specified end-bracket. IMS then places the workstation between-brackets and into a contention state by sending the entire IMS error message as a single chain with the appropriate bracket indicators.

An IMS error message can have multiple segments, with a maximum message length of 32,000 bytes. However, all current IMS error messages that are sent to the workstation are single-segment and less than 132 bytes. These messages adhere to the FM header and transmission rules for all output messages.

The generation of the user sense data is dependent on the standard IMS error message format. The session can be terminated if any user Output edit routine modifies this format.

## Controller or Station-Detected Errors

Whenever the controller detects an error on a message from IMS, or simply cannot accept the message at that time, an exception DR2 that includes 4 bytes of sense data is returned:

- Bytes 0, 1**      System sense field
- Bytes 2, 3**      User sense field

### System Sense Field

Bytes 0 and 1 should contain one of the following values:

<b>X'0802'</b>	RECOVERABLE ERROR—If the message is recoverable, IMS returns it to the output queue and retransmits it following the next input from that workstation or whenever additional output for that destination is queued. Retransmission of chained messages begins from the first-in-chain transmission. Because any open bracket is closed upon receipt of the exception DR2, the retransmitted message contains end-bracket only or both begin-bracket and end-bracket indicators (depending upon whether input occurred or whether the bracket indicators were specified). Irrecoverable messages have been dequeued and cannot be recovered and retransmitted.
<b>X'0811'</b>	BREAK—Cancel output. The output message is terminated. This message is dequeued from IMS and is not retransmitted; it is not subject to recovery. Any remaining output messages that are queued for the workstation are sent. If additional output is not available after receiving this sense code, IMS sends a null output message.  <b>Related Reading:</b> For more information on output messages, see "Output Messages" on page 479.
<b>X'0812'</b>	TEMPORARY ERROR—Resource not available. IMS action same as for X'0802'.
<b>X'0813'</b>	TEMPORARY ERROR, BID OR BRACKET REJECTED—NOT READY TO RECEIVE follows. IMS action is the same as for X'0802'.
<b>X'0814'</b>	TEMPORARY ERROR, BID OR BRACKET REJECTED—READY TO RECEIVE follows. IMS action is the same as for X'0802'.
<b>X'081C'</b>	STATION/COMPONENT DOWN—If byte 3 indicates a valid component (X'01' through X'04'), IMS marks the indicated component as inoperable. If byte 3 indicates X'00' or an invalid component (other than X'01' through X'04'), IMS interprets this as a session termination request and terminates the session. If the message in progress is recoverable, IMS returns it to the output queue and retransmits it when the workstation or component is again operable. Irrecoverable messages cannot be recovered and retransmitted.

Any other value for bytes 0 and 1 are handled as a request to terminate the session.

If the BID option is defined, the controller application program should use either X'0813' or X'0814' in an exception DR1 to the BID command; otherwise, the session is terminated because of an invalid response.

The X'0813' sense code results in the message being returned to the IMS output queue if it is recoverable, or dequeued if it is irrecoverable. Any recoverable data returned to the queue causes the bid to be sent again following the next input from the workstation, or whenever additional output for that destination is queued.

The X'0814' sense code causes a recoverable message to be returned to the IMS output queue, or a irrecoverable message to be dequeued. IMS then waits for an

RTR command. The workstation can now send input to IMS. Until an RTR is received, IMS does not initiate any output when in a between-brackets state. If IMS is left in an in-bracket send state (the last input carried BB/CD), IMS sends output with EB to terminate the current bracket.

### **User Sense Field**

This field is used when the system sense field is set to X'081C'. Byte 2 is not inspected by IMS and, therefore, can contain any value.

Byte 3 contains the hexadecimal identification (X'nn') of the component to which the output message is directed. IMS marks that component as inoperable and continues to send output to other operable components of the workstation. If X'00' or an invalid component is specified, the session is terminated.

IMS binds each session with unconditional bracket termination. This means that both IMS and the workstation go to between-brackets and contention states for all supported sense codes except X'0813' and X'0814'. For these two sense codes, IMS goes to between-brackets and receive states; the workstation goes to between-brackets and send states.

## **VTAM Logical Unit Status (LUSTATUS) Command**

If the SLU P system detects a component-down or workstation-down condition, and the SLU P system is not currently receiving a message from IMS, it can send the VTAM LUSTATUS command to notify IMS of the condition. Four bytes of data, identical in format to the exception DR1 or DR2 for STATION/COMPONENT DOWN, must accompany the LUSTATUS. When IMS receives the LUSTATUS, it marks the indicated component inoperable or terminates the session.

The workstation can also notify IMS when the component is operable by sending the VTAM LUSTATUS. The system sense field must equal X'0001', and the user sense field byte 3 must equal a value from X'01' through X'04'. IMS resets the inoperable condition for the indicated component and sends any output queued for it.

All other values for LUSTATUS are considered requests to terminate the session.

## **VTAM Ready-to-Receive (RTR) Command**

This is a summary of previously defined IMS functions performed upon receipt of an RTR command:

- Any outstanding Fast Path output message is dequeued and IMS removes the workstation from terminal response mode.
- Any output-protected components are marked unprotected and available for output.
- Output that is suspended because of a X'0814' sense code on a previous exception response is now allowed.
- If IMS output is available to be sent, IMS returns a DR1 response, immediately followed by the output message.
- If no IMS output is available, or if the workstation is in a status where no output can be sent (output stopped or quiesced), IMS returns an exception DR1 followed by an error message indicating no output is available.
- If an RTR is received during the transmission of MFS-paged output, IMS returns an exception DR1 followed by an error message indicating invalid paging request.

## Error Handling

- Any exception response returned by IMS causes any display component defined for the logical unit to be protected and unavailable for output.

### VTAM CANCEL Command

The VTAM CANCEL command is used by IMS, and should be used by the SLU P system to terminate a chained message in progress that has not completed. IMS sends the CANCEL command to a workstation in these situations:

- The IMS master terminal operator issues the IMS /DEQUEUE command and IMS has not yet sent the last-in-chain transmission of a message.
- IMS receives an exception DR1 or DR2 to a transmission of a message and has not yet sent the last-in-chain transmission.

The controller or controller application program should use the CANCEL command in these situations:

- When an exception DR1 or DR2 is received from IMS prior to sending the last-in-chain transmission of a message.
- When multi-RU chained input to IMS must be cancelled prior to sending the last-in-chain transmission of a message. In this case, if the message to be cancelled contains only the begin-bracket indicator, the VTAM CANCEL command can include the end-bracket indicator, the change-direction indicator, or no additional indicators.

### VTAM Request-Recovery Command

If, during its normal operation, a workstation detects an error condition that does not terminate the session with IMS but does cause the workstation to resynchronize with IMS (for example, diskette failure in the controller or a program check), the application program can initiate message resynchronization.

Initiation of message resynchronization is done by sending the request-recovery (RQR) command. IMS responds with a CLEAR command followed by the set-and-test-sequence-numbers (STSN) command. Message resynchronization follows and is the same as that described under "Message Recovery" on page 457.

**Restriction:** Session initiation and resynchronization caused by an SNA Request-Recovery (RQR) command is not allowed when the node is in response mode and the response reply message is not yet available for output; that is, the input response mode transaction is still queued or in the process of execution. Response-mode transactions are not recoverable or restartable prior to the application sync point; therefore, session input acknowledgement does not occur until input processing is complete.

Four bytes of data can accompany a SIGNAL command that is sent to IMS. The first two bytes are system-signal data. The last two bytes are user data that is ignored by IMS. The first two bytes are handled as follows, with all other values being ignored.:

- |                |   |
|----------------|---|
| <b>X'0000'</b> | No specific action is taken. This data can, however, cause IMS to send any available output for operative, unprotected components if the workstation is idle due to a previous exception DR1 or DR2 sent to IMS. This input does not reset the output component protection or display protection. |
| <b>X'0001'</b> | This data is treated as an attention signal that causes IMS to stop sending and to wait for input at the end of the current output  |

message. This type of signal can be used before sending either input or required DR1 or DR2 or exception DR1 or DR2 responses to IMS.

## Error Handling

---

## Part 8. Appendixes





---

## Appendix A. Using Programmed Symbols for IBM 3270

**Definition:** *Programmed Symbols (PS)*, an optional feature on the IBM 3270 terminal, lets you store and access up to six character sets of 190 characters each that are user-definable and program-loadable. After the coded graphic character sets have been loaded into the PS buffers, they can be used on a field-by-field basis using MFS.

If the PS buffers are desired and have not been loaded, they must be loaded by a VTAM application or by some other means.

**Related Reading:** For information on programmed symbols, their use, and loading, see *IBM 3270 Information Display System: 3274 Control Unit Description and Programmer's Guide*.

### **In this Appendix:**

- "Determining Whether the Buffers Are Loaded"
- "Loading the PS Buffer"
- "Solving Load Problems" on page 500
- "Reloading the PS Buffer" on page 501
- "Application Design Considerations" on page 501

---

### Determining Whether the Buffers Are Loaded

If you know that the buffers have already been loaded with the desired programmed symbols, you do not need to resend the entire load programmed symbols data stream. To determine if the buffers are loaded with the desired programmed symbols, use one of these methods:

- Maintain a handwritten log at the device and record the current status of the PS buffers.
- Run a test transaction that attempts to use the desired programmed symbols. Either the desired transaction's output is successfully displayed or an error message (DFS2078) is sent to the terminal and the message is returned to the IMS message queue, with the terminal left in protected mode. The message must be dequeued and a transaction started to load the programmed symbols buffer.

---

### Loading the PS Buffer

If the operator knows the PS buffers need to be loaded (because the device was just powered on), enter a response-mode transaction that loads programmed symbols. An installation-written application program that loads PS buffers should be made available for this purpose. The load PS data stream should be the first part of the message sent by the application program and a notification, such as THE PROGRAMMED SYMBOLS LOAD FOR pname COMPLETE should be the remainder. The notification informs the terminal operator when the programmed symbols have been loaded. This transaction requires the MFS bypass option.

**Related Reading:** For information on the MFS bypass option, see *IMS Version 9: Application Programming: Transaction Manager*.

## Loading the PS Buffer

When the output device for which the PS buffers are to be loaded includes a printer or a different display, another technique must be used.

**Example:** These events illustrate one example of using an automated operator application program:

1. The master terminal operator at Display\_A enters a transaction (response or conversational) requesting that programmed symbols be loaded for Display\_A, Printer\_B, and Display\_C.
2. In processing the transaction, an AOI program assigns LTERMs for Printer\_B and Display\_C, temporarily, to a special PTERM reserved for loading the PS buffers. The AOI program assigns dummy LTERMs to Printer\_B and Display\_C.
3. The AOI program inserts the message containing the load programmed symbols messages to the dummy LTERMs of Printer\_B and Display\_C.
4. The AOI program sends a programmed symbols message to Display\_A.
5. The master terminal operator visually verifies messages on both displays and the printer and confirms to the transaction that the load was successful.
6. The transaction reassigns the LTERMs back to their original status.

---

## Solving Load Problems

If a hardware error occurs while loading a programmed symbols buffer, the following actions occur:

1. The message used to load the programmed symbols is returned to the IMS message queue.
2. The terminal is taken out of service  
**Exception:** SLU 2 devices are not taken out of service.
3. The error is logged on the IMS log.
4. Message DFS2078 is sent to the IMS master terminal. For AOI purposes, provide the message number, if possible.

After the hardware error is corrected and the terminal is in service, the message to load the programmed symbols is re-sent.

If the loading of the programmed symbols fails because of an error in the message to load the programmed symbols, the operator must:

- Dequeue the message. The master terminal operator might need to issue the dequeue (/DEQ) command.
- Correct the error.
- Reenter the transaction to resend the programmed symbols load message.

If a method is available for informing the next user of the programmed symbols buffer status, the terminals with loaded PS buffers should not be powered off. When a power failure occurs or a terminal is powered off, the contents of the PS buffers might be lost.

When a terminal is powered on, if no IMS messages are waiting to be sent to the display, an IMS response mode transaction should be entered to load all required PS buffers or some non-IMS method should be used to load the PS buffers. However, if IMS messages are waiting to be sent, and these messages require the use of one or more PS buffers, sending the queued messages must be delayed until the PS buffers can be reloaded.

For SLU 2 devices, if the PS buffers are not loaded and a message requiring the use of a programmed symbols buffer is sent to the terminal, the message is rejected and IMS:

- Returns the invalid message to the IMS queue
- Logs the error on the IMS log
- Sends message DFS2078 to the IMS master terminal and to the node, indicating an output failure.

The terminal is left in protected mode after receipt of message DFS2078.

A user application program can be designed to queue to an LTERM an unsolicited message requiring a particular programmed symbols buffer to be loaded. The first part of the message can include a load programmed symbols data stream; however, this message cannot be processed by MFS.

---

### Reloading the PS Buffer

When a message is waiting on the IMS queue for a terminal and requires programmed symbols that are not loaded, take one of the following actions:

- If the terminal is attached by VTAM, load the PS buffers using a VTAM application.
- If a queued message requires a programmed symbols buffer, and it is normal user output (for example, the output is not response mode or conversational), then use a response-mode transaction to load the programmed symbols buffer, which loads the programmed symbols buffer so that the queued message is properly displayed.
- Dequeue (/DEQ) the message (or have the master terminal operator dequeue the message) requiring use of a programmed symbols buffer; enter a transaction to load the programmed symbols buffer required; and then reenter the transaction that originally generated the queued message.

---

### Application Design Considerations

A message that uses programmed symbols is different from other IMS output messages; it relies on the correct PS buffer content for its presentation. One application might require a PS buffer content that is incompatible with a different application. Further, the PS buffer can be erased by external action (such as powering off the terminal). IMS helps in managing this PS buffer by keeping messages that cannot be displayed on the IMS message queue; this allows the PS buffer to be loaded and the message re-sent.

Multiple output messages can be queued for the same device. IMS uses a set algorithm to determine which message to send to the terminal next. For example, response-mode output is always sent before any nonresponse-mode output messages are sent; this is very useful for programmed symbols, because it allows a transaction to be entered to load the PS buffer before other queued messages are sent to the terminal.

Provide a response-mode transaction to load the PS buffer. This transaction allows its output to overtake any nonresponse-mode output that requires the PS buffer to be loaded. A database keyed by LTERM name can be used to record the program symbol set name that is to be loaded into the buffer. All IMS applications using program symbols need to update this value whenever the PS buffer is loaded. In this way the terminal operator never needs to know the program symbol name.

## Application Design Considerations

|                   Output messages using PS should be sent as nonresponse-mode, allowing the PS  
|                   buffer to be reloaded using a special response-mode transaction (described in the  
|                   previous paragraph). An alternative is to use a non-IMS program to load the PS  
|                   buffer.

An Automated Operator Interface (AOI) routine can be triggered by the DFS2078 message, indicating a possible need to reload the PS buffer. This avoids the need for any human intervention. If you choose this technique, provide for invalid or corrupted 3270 data streams that produce the DFS2078 message, rather than an actual PS buffer problem. Be careful to design the AOI routine to detect and avoid looping if it automatically reactivates the terminal.

---

## Appendix B. Bind Parameters for SLU P and LU 6.1

This appendix lists the session parameters that IMS specifies when establishing connection using the VTAM OPNDST macro instruction. These parameters define the rules that a logical unit must follow when communicating with IMS.

**Restriction:** A VTAM restriction exists on the OUTBUF and RECANY buffer sizes for logical units requiring a bind from IMS.

**Related Reading:** For more information, see *IMS Version 9: Installation Volume 2: System Definition and Tailoring* and *Communications Server: SNA Resource Definition Reference*.

### **In this Appendix:**

- “Finance Communication System Bind Parameters”
- “LU Type 6.1 Bind Parameters” on page 505

The following outbound (from IMS to the SLU) BIND formats apply to the device types indicated in this appendix.

**Related Reading:** For information on the inbound (initial logon) user data format, which applies to non-ISC device types, see Appendix D, “Format for CINIT User Data Parameters,” on page 521.

---

## Finance Communication System Bind Parameters

The session parameters for a Finance Communication System, defined as UNITYPE=FINANCE or UNITYPE=SLUTYPEP on the TYPE macro or an Extended Terminal Option (ETO) logon descriptor, are set as shown in Table 72.

*Table 72. Finance Communication System Bind Parameters*

Byte	Bit	Content	BIND FORMAT Description
0		X'31'	
1		X'01'	Format=0; BINDTYPE=COLD <sup>1</sup>
2		X'04'	FM Profile 4
3		X'04'	TS Profile 4
4			Primary NAU protocol
	0	B'1'	Multiple RU chains
	1	B'0'	Immediate request
	2-3	B'11'	Any response
	4-5	B'00'	Reserved
	6	B'0'	No compression
	7	B'1'	Primary can send EB

## Finance Communication System Bind Parameters

Table 72. Finance Communication System Bind Parameters (continued)

Byte	Bit	Content	BIND FORMAT Description
5		B'1'	Secondary NAU protocol
	0	B'1'	Multiple RU chains
	1	B'0'	Immediate request
	2-3	B'11'	Any response
	4-5	B'00'	Reserved
	6	B'0'	No compression
	7	B'1'	Secondary can send EB
6		X'60'	Common NAU protocol
	0	B'0'	Reserved
	1	B'1'	Message headers are allowed
	2	B'1'	Brackets to be used
	3	B'0'	Bracket termination rule 2 (unconditional)
	4	B'0'	No alternate code
	5-7	B'000'	Reserved
7		X'80'	Common NAU protocol
	0-1	B'10'	FM transmission mode - HDX flip/flop
	2	B'0'	Primary ERP responsibility
	3	B'0'	Secondary station is the first speaker
	4-5	B'00'	Reserved
	6	B'0'	No related chains
	7	B'0'	Contention resolution
8			Reserved: X'00' should be specified
9			SLU receive pacing count: Not changed by IMS <sup>2</sup>
10			SLU max. RU send size: Set to maximum receive any buffer size from IMS system definition <sup>1, 3, 4</sup>
11			PLU max. RU send size: Set from output buffer size specified on IMS system definition <sup>1, 4</sup>
12-13			Reserved: X'0000' should be specified
14			LU TYPE: X'00' should be specified
15-26			Reserved: XL11'00' should be specified
27			PLU name length <sup>2</sup>
28-35			PLU name: IMS ACB name <sup>2</sup>
36		X'0B'	User data length
37-47			User data <sup>5</sup>
37		X'00'	Structured data indicator
38		X'09'	Length of USERVAR segment
39		X'03'	USERVAR segment indicator
40-47		XRF USERVAR	USERVAR

Table 72. Finance Communication System Bind Parameters (continued)

Byte	Bit	Content	BIND FORMAT Description
<b>Notes:</b>			
			1. Bytes 1 through 7, 10, and 11 are set to the indicated values set by IMS and cannot be changed by the user. The pacing parameter is defined in the VTAM list LU definition or through the mode table entry for the LU (VTAM DLOGMOD parameter).
			2. Bytes 0, 9, and 27 through 35 are set by VTAM.
			3. The receive-any buffer size is determined by the user-supplied value for size on the RECANY keyword parameter of the COMM macro statement, less 28 bytes. The resulting value is input to the algorithm described in <i>Communications Server: SNA Programming</i> .
			4. IMS does not set the buffer size for the 4701/4702.
			5. When the BIND data issued is an XRF system that uses the USERVAR instead of MNPS, the following structured user segment is included:
			<ul style="list-style-type: none"> <li>• Length of USERVAR segment - X'09'</li> <li>• USERVAR segment indicator - X'03'</li> <li>• USERVAR (8 bytes) - USERVAR of the XRF system</li> </ul>

## LU Type 6.1 Bind Parameters

This topic provides information on logical unit type 6.1 bind parameters.

### IMS as Primary Half Session

The following bind format is sent by IMS during an IMS-to-other session initiation. If the mode table entry indicates negotiated bind, IMS overrides the mode table primary NAU protocol field with the indicated values prior to sending the bind.

IMS allows some parameters to be optionally set by a VTAM mode table entry or negotiated bind response. IMS then operates within the indicated constraints. For a non-negotiated bind, IMS checks the parameters for validity before sending the bind. For negotiated bind, IMS checks the parameters for validity prior to sending the BIND request and upon receipt of the bind response, because the secondary half session can modify parameters within the constraints indicated in Table 73.

Table 73. Logical Unit Type 6.1 Bind Parameters

Byte	Bit	Content	BIND FORMAT Description <sup>1</sup>
0		X'31'	Bind request code
1	0-3	B'0000'	FORMAT: TYPE 0
	4-7	B'0000', B'0001'	BIND TYPE: 0000 - negotiated 0001 - non-negotiated
2	0-7	X'12'	FM Profile 18
3	0-7	X'04'	TS Profile 4

## LU Type 6.1 Bind Parameters

Table 73. Logical Unit Type 6.1 Bind Parameters (continued)

Byte	Bit	Content	BIND FORMAT Description <sup>1</sup>
4			Primary NAU protocol
	0	B'1'	Multiple RU chains
	1	B'0'	Immediate request
	2-3	B'10', B'11' (B'11' set for negotiated BIND)	10-Definite response chains 11-Exception/Definite response chains
	4	B'0'	Cannot send prepare
	5	B'0'	Reserved
	6	B'0'	No compression
	7	B'1'	0-Primary cannot end bracket 1-Primary can send end bracket
5			Secondary NAU protocol
	0	B'1'	0-Single RU chains, 1-Multiple RU chains
	1	B'0'	Immediate request
			01-Exception response chains
			10-Definite response chains
	2-3	B'10', B'11'	11-Exception/Definite response chains
	4	B'0'	Cannot send prepare
	5	B'0'	Reserved
6	6	B'0'	No compression
			0-Secondary cannot end bracket
	7	B'0', B'1'	1-Secondary can send end bracket
			Common NAU protocol
	0	B'0'	Reserved
	1	B'1'	Function management headers allowed
			Bracket state
			0 - Bracket state manager reset to in-bracket state
2	B'0',B'1'	1 - Bracket state mar reset to between-bracket state <sup>2</sup>	
3	B'1'	Conditional bracket termination	
4	B'0'	No alternate code	
5	B'0' Sequence numbers not available B'1' Sequence numbers available	STSN request flag	
6	B'0' BIS not sent B'1' BIS sent	BIS sent flag	
7	B'0'	Reserved	



## LU Type 6.1 Bind Parameters

Table 73. Logical Unit Type 6.1 Bind Parameters (continued)

Byte	Bit	Content	BIND FORMAT Description <sup>1</sup>
7	0-1	B'10'	FM transaction mode, HDX-FF
	2	B'1'	Sender ERP
	3	B'0'	Secondary is first speaker
	4-6	B'0000'	Reserved
			If byte 6 bit 2 is 0, then
			0-Secondary speaks first after data traffic active state
	7	B'0', B'1'	1-Primary speaks first after data traffic active state <sup>2</sup>
8	0-7	Unchanged	Secondary send pacing count
9	0-7	Unchanged	Secondary receive pacing count
10	0-7	Set from user Define receive-any	SLU max send RU size <sup>3</sup>
11	0-7	Set from user Define outbuffer size	PLU max send RU size
12	0-7	Unchanged	Primary send pacing count
13	0-7	Unchanged	Primary receive pacing count
			Presentation Services
14	0-7	X'06'	LU profile (LUTYPE6)
15	0-7	X'00' Reserved	Function management header subset
16	0	Reserved	Primary half-session flags
	1	Reserved	
	2	1 - FMH6: Receive SYSMSG supported	
	3	1 - Receive SCHEDULER model supported	
	4	1 - Receive QMODEL supported	
	5	0 - Linear file model ignored	
	6	0 - DL/I model ignored	
	7	Reserved	
17		Reserved	
18-19		Reserved	

## LU Type 6.1 Bind Parameters

Table 73. Logical Unit Type 6.1 Bind Parameters (continued)

Byte	Bit	Content	BIND FORMAT Description <sup>1</sup>
20	0	Reserved	Secondary half-session flags
	1	Reserved	
	2	1 - Receive SYSMMSG supported	
	3	0 - Receive SCHEDULER not supported <sup>4</sup> 1 - Receive SCHEDULER model supported	
	4	0 - Receive QMODEL ignored 1 - Receive QMODEL supported	
	5	0 - linear file model ignored	
	6	0 - DL/I model ignored	
	7	Reserved	
21		Reserved	
22-26		Reserved	
27	0-7		Length of PLU name
28-M			PLU name
M+1	0-7	X'00' No user data present	Length of user data
M+2-N		X'00' Structured fields follow ¬X'00' First byte of unstructured user data <sup>5</sup>	User data
M+3-N		Remainder of unstructured user data	For unstructured user data
M+3-N		Structured fields	For structured user data <sup>6</sup>
N+1	0-7	Structured fields, request correlation (URC) field X'00' = no URC present	Length of URC <sup>7</sup>
N+2-P		End-user-defined identifier	URC <sup>4</sup>
P+1	0-7	X'00'=no secondary name	Length of secondary LU name <sup>4</sup>
P+2-R	0-7	Secondary LU name	Secondary LU name <sup>4</sup>

Table 73. Logical Unit Type 6.1 Bind Parameters (continued)

Byte	Bit	Content	BIND FORMAT Description <sup>1</sup>
<b>Notes:</b>			
<ol style="list-style-type: none"> <li>1. The length of the BIND RU cannot exceed 256 bytes; otherwise, a negative response is returned.</li> <li>2. Set to indicate possible in-bracket or process restart. Set by IMS on bind when response mode output remains on the queue or when IMS is in conversational mode. Can also be sent on a negotiated bind response by the other half session.</li> <li>3. The receive-any buffer size is determined by the user-supplied value for size on the RECANV keyword parameter of the COMM macro statement, less 28 bytes. The resulting value is input to the algorithm described in <i>Communications Server: SNA Programming</i>.</li> <li>4. When the bind indicates that the other half session does not support the SCHEDULER process, IMS sends all unsolicited and asynchronous output using ATTACH.</li> <li>5. Unstructured user data is ignored and not provided by IMS.</li> <li>6. Structured user data formats. A structured field contains architected or subsystem-defined information and provides a means for subsystems to communicate data. Each structured field contains a field identifier (subfield number) and length. A structured data field can contain unstructured data. If structured field (M+3-N) is X'00', it contains unstructured data as follows:               <ol style="list-style-type: none"> <li>1 Length of unstructured data field (including subfield key field). If zero, this field can be omitted entirely.</li> <li>2 Subfield key: X'00'</li> <li>3-N Unstructured data. If the structured subfield number is X'03', an 8-byte USERVAR name follows the subfield.</li> </ol>               If the structured field (M+3-N) is X'01', it contains a session qualifier as follows:               <ol style="list-style-type: none"> <li>1 Length of session qualifier field (including subfield key field). If zero, this field can be omitted entirely.</li> <li>2 Subfield key: X'01'</li> <li>3 Length of primary resource qualifier (X'00' means no primary source qualifier is present). Values 0 to 8 are valid.</li> <li>4-N Primary resource qualifier</li> <li>N+1 Length of secondary resource qualifier (X'00' means no secondary resource qualifier is present). Values 0 to 8 are valid.</li> <li>N+2-M Secondary resource qualifier</li> <li>M+1 Length of password (X'00' means no password is present). Values 0 to 8 are valid.</li> <li>M+2-P Password. Ignored on bind or bind reply from IMS and is not sent on bind or bind reply. IMS indexes structured fields to find field X'01', a session-qualifier field, when these parameters are required for session initiation using parallel sessions.</li> <li>M+3-N If the structured field has a subfield of X'02', IMS interprets the field as an MSC partner ID. If bind is issued in an XRF environment that uses USERVAR instead of MNPS, an additional structured segment is included in the user data. The format of this segment is:                   <ol style="list-style-type: none"> <li>1 Length of USERVAR segment, X'09'</li> <li>2 Subfield key, X'03'</li> <li>3-10 8-byte field containing USERVAR of the XRF complex</li> </ol> </li> </ol> </li> <li>7. The URC and secondary LU name are not used by IMS but are shown for compatibility purposes.</li> </ol>			

## IMS as Secondary Half Session

The bind format in Table 74 can be received by IMS during an IMS-to-other session initiation. If the bind parameters received indicated a negotiated BIND request, IMS overrides the secondary NAU protocol field with the indicated values before sending the bind response.

IMS allows some parameters to be optionally set using the bind and operates within the indicated constraints.

Table 74. IMS-To-Other Secondary Half Session

Byte	Bit	Content	BIND FORMAT Description <sup>1</sup>	
0		X'31'	Bind Request Code	
1	0-3	B'0000'	Format: TYPE 0	
	4-7	B'0000', B'0001'	Bind type: 0000 - negotiated 0001 - non-negotiated	
2	0-7	X'12'	FM profile 18	
3	0-7	X'04'	TS profile 4	
4			Primary NAU Protocol	
	0	B'0', B'1'	<b>B'0'</b> Single RU chains <b>B'1'</b> Multiple RU chains	
	1	B'01', B'10'	Immediate request: <b>B'01'</b> Exception response chains <b>B'10'</b> Definite response chains	
	2-3	B'01', B'10', B'11'	11-Exception/Definite response chains	
	4	B'0'	Cannot send prepare	
	5	B'0'	Reserved	
	6	B'0'	No compression	
	7	B'0', B'1'	0-Primary cannot end bracket 1-Primary can send end bracket	
	5			Secondary NAU Protocol
		0	B'1'	Multiple RU chains
1		B'0'	Immediate request	
2-3		B'10', B'11' (B'11' set for negotiated bind)	10-Definite response chains 11-Exception/Definite response chains	
4		B'0'	Cannot send prepare	
5		B'0'	Reserved	
6		B'0'	No compression	
7		B'1'	0-Secondary cannot send end bracket 1-Secondary can send end bracket	
6			Common NAU Protocol	

## LU Type 6.1 Bind Parameters

Table 74. IMS-To-Other Secondary Half Session (continued)

Byte	Bit	Content	BIND FORMAT Description <sup>1</sup>
	0	B'0'	Reserved
	1	B'1'	Function Management headers allowed
	2	B'0', B'1'	Bracket state: <b>B'0'</b> Bracket state manager reset to in-bracket state <b>B'1'</b> Bracket state manager reset to between-bracket state <sup>2</sup>
	3	B'1'	Conditional bracket termination
	4	B'0'	No alternate code
	5	B'0', B'1'	STSN required flag: <b>B'0'</b> Sequence numbers not available <b>B'1'</b> Sequence numbers available
	6	B'0', B'1'	BIS sent flag: <b>B'0'</b> BIS not sent <b>B'1'</b> BIS sent
	7	B'000'	Reserved
7	0-1	B'10'	FM transaction mode, HDX-FF
	2	B'1'	Sender ERP
	3-6	B'0000'	Reserved
	7	B'0', B'1'	IF byte 6 bit 2 is 0: 0 - Secondary speaks first after data traffic active state 1 - Primary speaks first after data traffic active state <sup>2</sup>
8	0-7	Unchanged	Secondary send pacing count
9	0-7	Unchanged	Secondary receive pacing count
10	0-7	Must $\geq$ defined outbuffer size	SLU max send RU size
11	0-7	Must be $\leq$ define receive-any size	PLU max send RU size <sup>3</sup>
12	0-7	Unchanged	Primary send pacing count
13	0-7	Unchanged	Primary receive pacing count
14	0-7	X'06'	LU profile (LUTYPE6)
15	0-7	X'00' Reserved	Function Management header subset

## LU Type 6.1 Bind Parameters

Table 74. IMS-To-Other Secondary Half Session (continued)

Byte	Bit	Content	BIND FORMAT Description <sup>1</sup>	
16	0	Reserved	Primary half-session flags	
	1	Reserved		
	2	1 - Receive SYSMMSG supported		
	3	0		0 - Receive SCHEDULER model not supported <sup>4</sup>
		1		1 - Receive SCHEDULER model supported
	4	0		0 - Receive QMODEL not supported
		1		1 - Receive QMODEL supported
	5	0 - linear file model not supported		
6	0	0 - DL/I model not supported		
	7	Reserved		
17		Reserved		
18-19		Reserved		
20	0	Reserved	Secondary half-session flags	
	1	Reserved		
	2	1 - FMH6: Receive SYSMMSG supported		
	3	1 - Receive schedule model supported		
	4	1 - Receive QMODEL supported		
	5	0 - linear file model not supported		
	6	0 - DL/I model not supported		
	7	Reserved		
21		Reserved		
22-26		Reserved		
27	0-7		Length of PLU name	
28-M			PLU name	
M+1	0-7	X'00' No user data present	Length of user data	
M+2-N		X'00' Structured fields follow -X'00' first byte of unstructured user data <sup>5</sup>	User data	
M+3-N		Remainder of unstructured user data	For unstructured user data	

*Table 74. IMS-To-Other Secondary Half Session (continued)*

<b>Byte</b>	<b>Bit</b>	<b>Content</b>	<b>BIND FORMAT Description<sup>1</sup></b>
M+3-N		Structured fields <sup>6</sup>	For structured user data
N+1	0-7	Length of user request correlation (URC) field X'00' = no URC present	Length of URC <sup>7</sup>
N+2-P		URC: end-user defined identifier	URC <sup>7</sup>
P+1	0-7	X'00'=no secondary name	Length of secondary LU name <sup>7</sup>
P+2-R	0-7	Secondary LU name	Secondary LU name <sup>7</sup>

## LU Type 6.1 Bind Parameters

Table 74. IMS-To-Other Secondary Half Session (continued)

Byte	Bit	Content	BIND FORMAT Description <sup>1</sup>																						
<b>Notes:</b>																									
<ol style="list-style-type: none"> <li>The length of the BIND RU cannot exceed 256 bytes; otherwise, a negative response is returned.</li> <li>Set to indicate possible in-bracket or process restart. Set by IMS on bind when response mode output remains on the queue or when IMS is in conversational mode. Can also be sent on a negotiated bind response by the other half session.</li> <li>The receive-any buffer size is determined by the user-supplied value for size on the RECANV keyword parameter of the COMM macro statement, less 28 bytes. The resulting value is input to the algorithm described in <i>Communications Server: SNA Programming</i>.</li> <li>When the bind indicates that the other half session does not support the SCHEDULER process, IMS sends all unsolicited or asynchronous output using ATTACH.</li> <li>Unstructured user data is ignored and not provided by IMS.</li> <li>Structured user data formats. A structured field contains architected or subsystem-defined information and provides a means for subsystems to communicate data. Each structured field contains a field identifier (subfield number) and length. A structured data field can contain unstructured data. If structured field (M+3-N) is X'00', it contains unstructured data as follows:           <table border="0"> <tr> <td style="padding-right: 20px;">1</td> <td>Length of unstructured data field (including subfield key field). If zero, this field can be omitted entirely.</td> </tr> <tr> <td>2</td> <td>Subfield key: X'00'</td> </tr> <tr> <td>3-N</td> <td>Unstructured data If the structured subfield number is X'03', an 8-byte USERVAR name follows the subfield.</td> </tr> </table>           If the structured field (M+3-N) is X'01', it contains a session qualifier as follows:           <table border="0"> <tr> <td style="padding-right: 20px;">1</td> <td>Length of session qualifier field (including subfield key field). If zero, this field can be omitted entirely</td> </tr> <tr> <td>2</td> <td>Subfield key: X'01'</td> </tr> <tr> <td>3</td> <td>Length of primary resource qualifier (X'00' means no primary source qualifier is present). Values 0 to 8 are valid.</td> </tr> <tr> <td>4-N</td> <td>Primary resource qualifier</td> </tr> <tr> <td>N+1</td> <td>Length of secondary resource qualifier (X'00' means no secondary resource qualifier is present). Values 0 to 8 are valid.</td> </tr> <tr> <td>N+2-M</td> <td>Secondary resource qualifier</td> </tr> <tr> <td>M+1</td> <td>Length of password (X'00' means no password is present). Values 0 to 8 are valid.</td> </tr> <tr> <td>M+2-P</td> <td>Password (ignored on bind or bind reply received by IMS and not sent on bind or bind reply. IMS indexes structured fields to find field X'01', a session-qualifier field, when these parameters are required for session initiation using parallel sessions.</td> </tr> </table>           When the BIND data issued is an XRF system that uses USERVAR instead of MNPS, the following structured user segment is included:           <ul style="list-style-type: none"> <li>• Length of USERVAR segment - X'09'</li> <li>• USERVAR segment indicator - X'03'</li> <li>• USERVAR (8 bytes) - USERVAR of the XRF system</li> </ul> </li> <li>The URC and secondary LU name are not used by IMS but are shown for compatibility purposes.</li> </ol>				1	Length of unstructured data field (including subfield key field). If zero, this field can be omitted entirely.	2	Subfield key: X'00'	3-N	Unstructured data If the structured subfield number is X'03', an 8-byte USERVAR name follows the subfield.	1	Length of session qualifier field (including subfield key field). If zero, this field can be omitted entirely	2	Subfield key: X'01'	3	Length of primary resource qualifier (X'00' means no primary source qualifier is present). Values 0 to 8 are valid.	4-N	Primary resource qualifier	N+1	Length of secondary resource qualifier (X'00' means no secondary resource qualifier is present). Values 0 to 8 are valid.	N+2-M	Secondary resource qualifier	M+1	Length of password (X'00' means no password is present). Values 0 to 8 are valid.	M+2-P	Password (ignored on bind or bind reply received by IMS and not sent on bind or bind reply. IMS indexes structured fields to find field X'01', a session-qualifier field, when these parameters are required for session initiation using parallel sessions.
1	Length of unstructured data field (including subfield key field). If zero, this field can be omitted entirely.																								
2	Subfield key: X'00'																								
3-N	Unstructured data If the structured subfield number is X'03', an 8-byte USERVAR name follows the subfield.																								
1	Length of session qualifier field (including subfield key field). If zero, this field can be omitted entirely																								
2	Subfield key: X'01'																								
3	Length of primary resource qualifier (X'00' means no primary source qualifier is present). Values 0 to 8 are valid.																								
4-N	Primary resource qualifier																								
N+1	Length of secondary resource qualifier (X'00' means no secondary resource qualifier is present). Values 0 to 8 are valid.																								
N+2-M	Secondary resource qualifier																								
M+1	Length of password (X'00' means no password is present). Values 0 to 8 are valid.																								
M+2-P	Password (ignored on bind or bind reply received by IMS and not sent on bind or bind reply. IMS indexes structured fields to find field X'01', a session-qualifier field, when these parameters are required for session initiation using parallel sessions.																								



---

## Appendix C. Bind Parameters for SLU 1 and SLU 2

This appendix lists the session parameters that IMS specifies when establishing connection with SLU 1 and SLU 2. These parameters define the rules that a logical unit must follow when communicating with IMS.

### **Related Reading:**

- For more information on using these parameters, see “Specifying Logon Modes When Establishing Connection” on page 265.
- For information on the BIND parameters for SLU P and LU 6, see Appendix B, “Bind Parameters for SLU P and LU 6.1,” on page 503.

### **In this Appendix:**

- “SLU 1 Bind Parameters”
- “SLU 2 Bind Parameters” on page 517

The following outbound (from IMS to the SLU) BIND formats apply to the device types indicated in this appendix.

**Related Reading:** For the inbound (initial logon) user data format, which applies to non-ISC device types, see Appendix D, “Format for CINIT User Data Parameters,” on page 521.

---

### SLU 1 Bind Parameters

The SLU 1 bind parameters are set as shown in Table 75.

*Table 75. SLU 1 Bind Parameters*

Byte	Bit	Content	Description
0		X'01'	Format=0; BINDTYPE=COLD
1		X'03'	FM Profile 3
2		X'03'	TS Profile 3
3			<b>PRIMARY LU PROTOCOLS</b>
	0	B'1'	Multiple RU chains
	1	B'0'	Immediate Request Mode
	2-3	B'11'	Chain Response Protocol: Any
	4-5	B'00'	Reserved
	6	B'0'	No Compression
	7	B'1'	Primary can send End Bracket
4			<b>SECONDARY LU PROTOCOLS</b>
	0	B'1'	Multiple RU Chains
	1	B'0'	Immediate Request Mode
	2-3	Note 1	Chain Response Protocol
	4-5	B'00'	Reserved
	6	B'0'	No Compression
	7	B'0'	Secondary does not send End Bracket

## SLU 1 Bind Parameters

Table 75. SLU 1 Bind Parameters (continued)

Byte	Bit	Content	Description
5			<b>COMMON LU PROTOCOLS (FIRST BYTE)</b>
	0	B'0'	Reserved
	1	Note 2	FM Headers
	2	B'1'	Brackets can be used
	3	B'1'	Bracket Termination Rule 1 (Conditional)
	4	B'0'	EBCDIC (No Alternate Code)
	5-7	B'000'	Reserved
6			<b>COMMON LU PROTOCOLS (SECOND BYTE)</b>
	0-1	B'10'	Half-Duplex Flip-Flop
	2	B'0'	Primary ERP Responsibility
	3	B'0'	Secondary is First Speaker
	4-6	B'000'	Reserved
	7	B'0'	Secondary is Contention Winner
7	0-1	B'00'	Reserved
	2-7		SLU Send Pacing Count (Set by VTAM) <sup>3</sup>
8	0-1	B'00'	Reserved
	2-7		SLU Receive Pacing Count (Set by VTAM) <sup>3</sup>
9	0-7	Set from user-defined receive any	SLU to PLU RU Size
10	0-7	Set from user-defined outbuffer size	PLU to SLU RU Size
11	0-1	B'00'	Reserved
	2-7		PLU CPMGR Send Pacing Count (Set by VTAM) <sup>3</sup>
12	0-1	B'00'	Reserved
	2-7		PLU CPMGR Receive Pacing Count (Set by VTAM) <sup>3</sup>
13	0-7	X'01'	LU Profile (LUTYPE1)
14-35		See Notes	Remainder of Bind Area

Table 75. SLU 1 Bind Parameters (continued)

Byte	Bit	Content	Description
<b>Notes:</b>			
1. IMS forces flip-flop mode.			
2. The preceding bind (bytes 0-6 and 13) overrides anything that might be in a logmode entry.			
3. You can do this by coding the VPACING parameter on the VTAM list LU definition or by specifying the appropriate mode table entry on the LU definition by using the VTAM DLOGMOD parameter.			
4. The remainder of the bind (bytes 14-35) can be specified if it is required by the device. It is taken from the logmode entry.			
5. Unattended operation must be specified in the logmode entry using the following:			
<b>BYTE 18</b>			
<b>Bit 0</b>			
	0	Initiates attended	
	1	Initiates unattended	
<b>Bit 1</b>			
	0	Does not alternate from attended/unattended during session	
	1	Alternates from attended/unattended during session	
IMS forces attended mode if the node is defined as the master terminal.			
6. IMS users should make the logmode entry according to the IMS definition.			
7. If the terminal sends SCS2 transparent fields (identified by a X'35' followed by one byte containing the field's length, followed by the transparent field), the bind image bit BINPDSB1=BINTRNDS (offset 17=01) must be set. IMS processes these fields by deleting the X'35' and length byte, and by passing the unaltered transparent field to the editing routine.			
8. IMS accepts a setting of B'10' (definite response), B'01' (exception response), or B'11' (either response). If a setting of B'00' is found, IMS sets B'01' if only the first component is defined, and B'10' if more than one component is defined.			
9. IMS leaves this bit on (FM headers allowed). If off, IMS leaves it off (FM headers not allowed) if only one component is defined, and sets it on if more than one component are defined.			

## SLU 2 Bind Parameters

The bind parameters for SLU 2 devices are set as shown in Table 76.

Table 76. SLU 2 Bind Parameters

Byte	Bit	Content	Description
0		X'01'	Format=0; BINDTYPE=COLD
1		X'03'	FM Profile 3
2		X'03'	TS Profile 3

## SLU 2 Bind Parameters

Table 76. SLU 2 Bind Parameters (continued)

Byte	Bit	Content	Description
3			Primary NAU protocol
	0	B'1'	Multiple RU chains
	1	B'0'	Immediate request
	2-3	B'11'	Any response
	4-5		Reserved
	6	B'0'	No compression
	7	B'1'	Primary can send EB
4			Secondary NAU protocol
	0	B'1'	Multiple RU chains
	1	B'0'	Immediate request
	2-3	B'01'	Exception response
	4-5		Reserved
	6	B'0'	No compression
	7	B'0'	Secondary cannot send EB
5			Common NAU protocol
	0		Reserved
	1	B'0'	Message headers are not allowed
	2	B'1'	Brackets to be used
	3	B'1'	Bracket termination rule 1 (conditional)
	4	B'0'	No alternate code
	5-7		Reserved
6			Common NAU protocol
	0-1	B'10'	FM transmission mode: HDX flip/flop
	2	B'0'	Primary ERP responsibility
	3	B'0'	Secondary station is the first speaker
	4-6	xxx	Reserved
	7	B'0'	For HDX-FF mode, secondary sends first when leaving data traffic reset state
7			SLU Send Pacing count: Not changed by IMS
8			SLU Receive Pacing count: Not changed by IMS
9			SLU MAX RU send size: Set to Max receive any buffer size from IMS system definition
10			PLU MAX RU send size: Set from output buffer size specified at IMS system definition
11-12			Reserved: X'0000' should be specified
13			LU TYPE: Set to X'02' by IMS
14-18			Reserved: X'00' should be specified
19-20			User specified screen size if 3274/3276 device. Otherwise not changed.

Table 76. SLU 2 Bind Parameters (continued)

Byte	Bit	Content	Description
21-22			Alternate screen size, X'00' should be specified.
23			Set to X'7E' if 3274/3276 NDS device or X'02' if non-NDS 3270 master terminal. Otherwise should be X'00'.
24-25			User specified: should be X'00'
26			PLU Name length
27-34			PLU name: IMS ACB name
35			User data length: Not supported, X'00' must be specified

**Notes:**

1. Bytes 0-6, 9, and 10 are set to the indicated values by IMS and cannot be changed by the user.
2. Byte 8 and bytes 26 through 34 are set by VTAM. You should set the remaining bytes to 0 (zero), but it is not mandatory.

## SLU 2 Bind Parameters

---

## Appendix D. Format for CINIT User Data Parameters

This appendix describes the CINIT user data parameters, and the syntax rules for them.

For all non-MSA VTAM terminal types, IMS can receive user data parameters from the following sources:

- IMS (/OPNDST command)
- IMS autologon request
- User logon (such as SNA INITSELF command)
- Installation Logon exit routine (DFSLGNX0)
- Signon exit routine (DFSSGNX0)
- Output Creation exit routine (DFSINSX0)

User data parameters are optional for migration purposes.

**Exception:** When a match must be made between the terminal and user for session initiation, user data parameters are required for:

- ISC parallel session (LU 6.1 architecture)
- Finance (3601) and SLU P terminals, when used with ETO

All parameters, optional and required, appear in the CINIT user data field and are available to IMS when the VTAM Logon exit routine is scheduled.

During logon and signon processing, IMS performs minimal processing on CINIT user data parameters before calling the Logon exit routine (DFSLGNX0) and the Signon exit routine (DFSSGNX0). If the Logon or Signon exit routines are not supplied, IMS assumes a default user data format, as defined in Figure 65.

**Related Reading:** For the ISC LU 6.1 architected format, see *Systems Network Architecture Format and Protocol Reference: Architectural Logic*.

The format for the user data is shown in Figure 65.

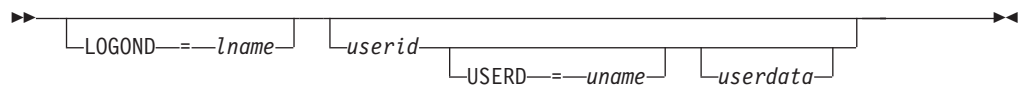

Figure 65. User Data Format

**Recommendation:** For these parameters, blanks are required and are the only recognized delimiters. You should not use more than one blank to delimit parameters.

**Restrictions:**

- The LOGOND and USERD parameters are valid only for ETO.
- For ISC parallel sessions, DFSLGNX0 receives only the user ID that translates to the ISC subpool name (SNA PHA/SHA qualifier).
- userid is required for Finance, SLU P, ISC, and output-only devices (such as printers).

## Format for CINIT User Data Parameters

The parameters specify the following:

Parameter	Description								
<b>LOGOND=</b> <i>lname</i>	Specifies logon descriptor name to be used for the terminal attempting to log on to IMS. <i>lname</i> is one to eight bytes in length.								
<i>userid</i>	Specifies the user ID of the user logging on to IMS. Supplying <i>userid</i> indicates that the user associated with this ID will also sign on to IMS. <i>userid</i> is one to eight bytes in length.  <b>Restriction:</b> ISC is restricted to only the user ID that translates to the ISC SUBPOOL name (SNA PHS/SHS qualifier).								
<b>USERD=</b> <i>uname</i>	Specifies the user descriptor name to be used for creating the user control block structure at signon. <i>uname</i> is one to eight bytes in length.								
<i>userdata</i>	Specifies additional data for the Signon exit routine (DFSSGNX0) or the Sign On/Off Security exit routine (DFSCSGN0) and security products, such as RACF. For the exit routines, your installation defines the format of the <i>userdata</i> fields. For RACF, the format of the <i>userdata</i> is: <table><thead><tr><th>Parameter</th><th>Description</th></tr></thead><tbody><tr><td><i>userpw</i></td><td>Identifies the user password associated with the previously entered <i>userid</i>. No keyword precedes the user password. The password is one to eight bytes in length.</td></tr><tr><td><b>GROUP</b> <i>groupname</i></td><td>Identifies <i>groupname</i> as the group name associated with the <i>userid</i>. The GROUP keyword and associated parameter are optional. The group name is one to eight bytes in length.</td></tr><tr><td><b>NEWPW</b> <i>nuserpw</i></td><td>Identifies <i>nuserpw</i> as a new user password that replaces the current password, <i>userpw</i>.</td></tr></tbody></table>	Parameter	Description	<i>userpw</i>	Identifies the user password associated with the previously entered <i>userid</i> . No keyword precedes the user password. The password is one to eight bytes in length.	<b>GROUP</b> <i>groupname</i>	Identifies <i>groupname</i> as the group name associated with the <i>userid</i> . The GROUP keyword and associated parameter are optional. The group name is one to eight bytes in length.	<b>NEWPW</b> <i>nuserpw</i>	Identifies <i>nuserpw</i> as a new user password that replaces the current password, <i>userpw</i> .
Parameter	Description								
<i>userpw</i>	Identifies the user password associated with the previously entered <i>userid</i> . No keyword precedes the user password. The password is one to eight bytes in length.								
<b>GROUP</b> <i>groupname</i>	Identifies <i>groupname</i> as the group name associated with the <i>userid</i> . The GROUP keyword and associated parameter are optional. The group name is one to eight bytes in length.								
<b>NEWPW</b> <i>nuserpw</i>	Identifies <i>nuserpw</i> as a new user password that replaces the current password, <i>userpw</i> .								

The ETO logon descriptor name, *lname*, applies to IMS logon processing. All remaining optional parameters, however supplied, are passed to ETO user allocation, signon processing, and the security product, such as RACF. If a security product is used, all parameters not applicable to that product must be deleted before it is called. The parameters can be deleted in DFSLGNX0, DFSSGNX0, and DFSCSGN0.



---

## Appendix E. SNA Character String Controls

This appendix provides information on SNA character string controls (SCS), which describe specific functions for the EBCDIC control codes. The primary functions defined are those that format a printed page or an alphanumeric display screen. Functions are also defined for codes that set modes of device operation, define data to be used in a unique fashion, or are used for communication between a device operator and an application program (where the specific function associated with the code is defined in a protocol established between a program and an operator).

An SCS data stream consists of a sequential string of control and data characters. Control function characters in the form of SCS-defined control codes can be intermixed with graphic data characters. Other data types (such as binary and packed decimal) are permitted only in conjunction with the transparent (TRN) control.

SCS control codes appear within the data portion of the request unit (RU). A function management (FM) header can precede SCS data within an RU. Functions such as component selection are performed by FM header functions and are not included as SCS functions.

SCS functions do not include data flow control functions, even when these functions are available to a keyboard operator through keys on the keyboard. For example, CANCEL is a data flow control request that can be initiated by a key on the keyboard.

### **In this Appendix:**

- “Format Controls”
- “Control Function Code Assignments” on page 524

---

## Format Controls

The formatting control functions format the output media at the device on a line and page basis. In addition to these controls, a device using SCS also automatically formats the character string to fit the line length of the device. Automatic new line generation eliminates device line length dependencies from those applications in which a specific output format is not required. Therefore, the same character string is sent to devices with varying line length capabilities without the requirement to reformat the character string.

Where specific line and page formats are required, the formatting control functions are used. The automatic new line feature is always active; however, a character string formatted for a given line length can be presented on a device with a shorter line length without loss of data, but the format is lost. When the situation is reversed, where a character string constructed for a maximum presentation position is less than the line length of the device to which it is directed, use of the smaller maximum presentation position allows the string to be presented without loss of format.

### Control Function Code Assignments

SCS control functions are assigned to EBCDIC codes as shown in Table 77.

Table 77. Control Function Code Assignments

EBCDIC Code	Function	Function Abbreviation
04	Vertical Channel Select	VCS <sup>1</sup>
05	Horizontal Tab	HT
0B	Vertical Tab	VT
0C	Form Feed	FF
0D	Carrier Return	CR
14	Enable Presentation	ENP
15	New Line	NL
16	Back Space	BS
17	Program Operator	POC <sup>1</sup>
24	Inhibit Presentation	INP
25	Line Feed	LF
2B	Format	FMT <sup>1</sup>
34	Presentation Position	PP <sup>1</sup>
35	Transparent	TRN <sup>1</sup>

**Note:**

1. Functions with parameters

**Definitions:** Parameters in SCS can be one of two types:

- *Function parameters* extend the function defined by the function code. For example, the PP control function has a function parameter to explicitly define the positioning function performed. The form for a function parameter is a single EBCDIC character.
- *Value parameters* specify a numeric value for the function. For example, the PP function also has a value parameter for it. If the move is relative to the current position, the value parameter specifies the number of columns or lines the presentation position is to be moved from its current position. If the move is absolute, the value parameter specifies the absolute column or line number to which the presentation position is to move. The form for a value parameter is a 1-byte binary number.

---

## Appendix F. Examples Using ISC Edit ATTACH Parameters

This appendix provides examples of using ISC edit ATTACH parameters.

### **In this Appendix:**

- “ATTACH and SCHEDULER Parameters with ISC Edit”
- “ATTACH Parameters with the IMS SYSMMSG Process” on page 527
- “ATTACH and SCHEDULER Parameters with IMS MFS” on page 529

---

### **ATTACH and SCHEDULER Parameters with ISC Edit**

The following examples shown in Figure 66, Figure 67 on page 526, and Figure 68 on page 527, illustrate the use of the ATTACH parameters when using ISC edit for IMS input and output messages.

ISC edit is used for normal transactions, commands, and message switches between LTERMs when one of the following occurs:

- An ATTACH FM header is received while in a between-brackets state that does not specify a destination process name (DPN).
- The DPN names IMS ISC edit as defined during IMS system definition.
- No ATTACH FM header is received either when the attach manager is in the between-brackets reset state or when the active process is ISC edit.
- The DPN=ISCEDT.

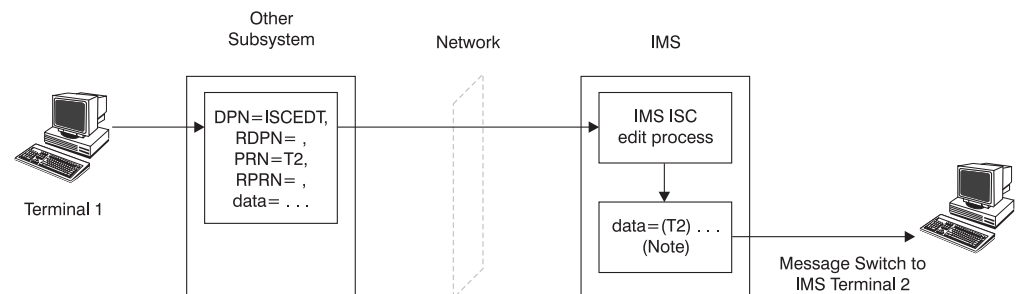

Figure 66. Example 1: Message Switch from Other Subsystem Terminal to IMS Terminal

**Note:** The IMS LTERM name for terminal T2 can be supplied either as the input primary resource name (PRN) or as the first field in the data.

## ATTACH and SCHEDULER Parameters with ISC Edit

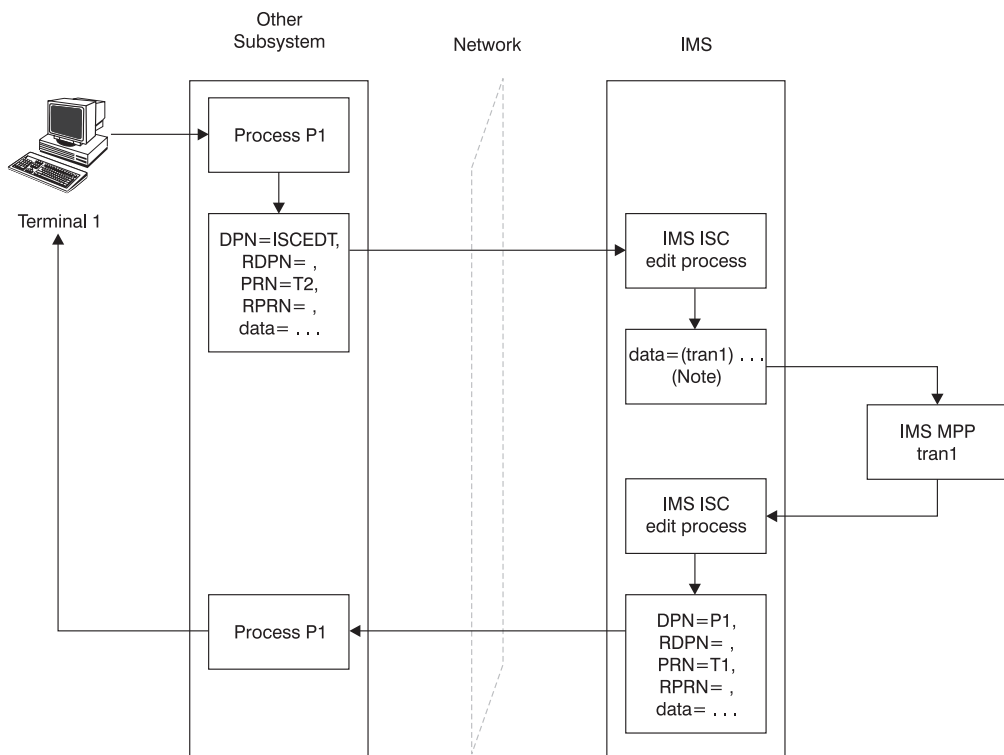

Figure 67. Example 2: Other Subsystem Accesses IMS Application Program with Reply Back to Other Subsystem Terminal

**Note:** The IMS transaction code can be supplied either as the input PRN or within the data. The input RDPN and RPRN parameters become the DPN and PRN parameters respectively for any resulting reply from the application program when not processed by MFS.

In Figure 68 on page 527, messages are routed from IMS Terminal 1 to the ISC edit process through either a message switch or an MPP or Fast Path message routing application. The ISC edit process uses SCHEDULER parameters to send the message to a transaction on another subsystem. The other subsystem then sends the message back to IMS and the ISC edit process using similar SCHEDULER parameters. The ISC edit process directs the message back to Terminal 1.

## ATTACH and SCHEDULER Parameters with ISC Edit

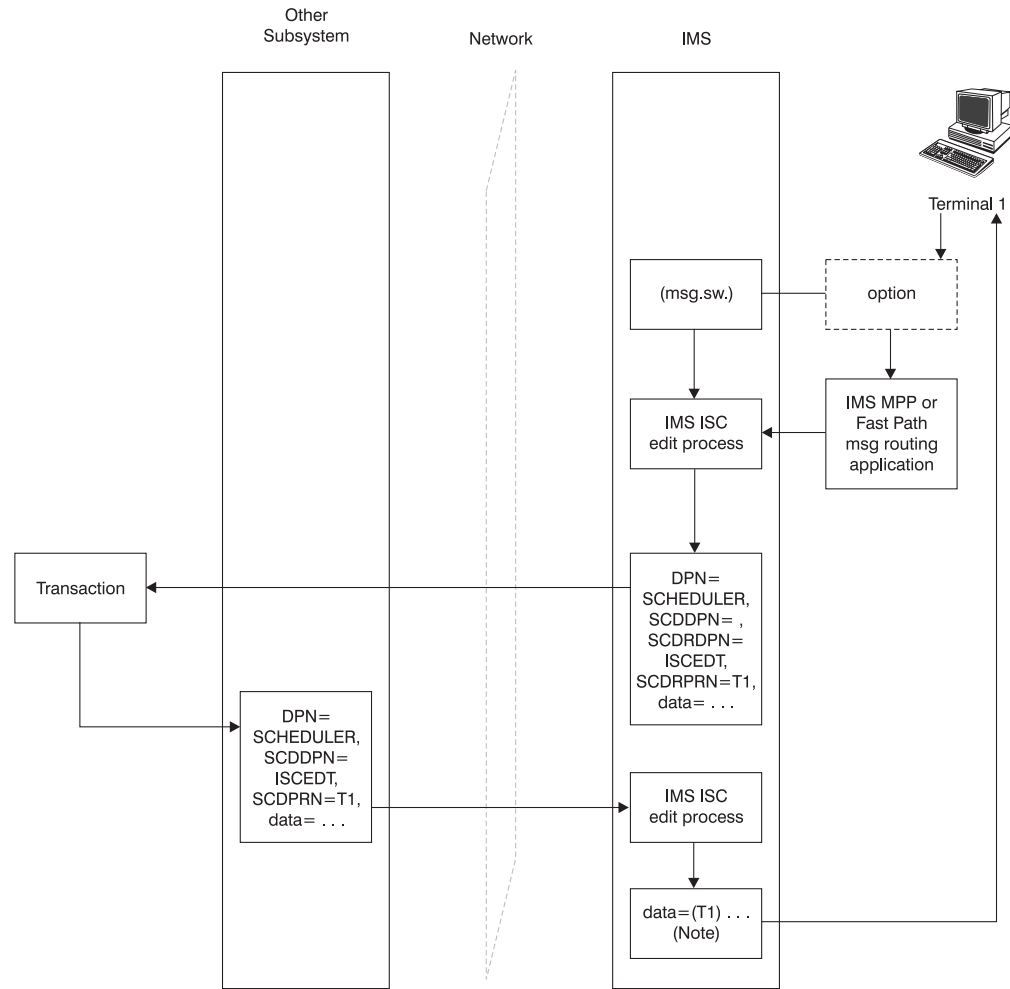

Figure 68. Example 3: Message Routing

**Note:** The IMS LTERM name can be supplied either as the input SCDPRN or the first data field.

## ATTACH Parameters with the IMS SYSMMSG Process

The system message process (SYSMMSG) is indicated through a special SNA process name in the ATTACH header.

Input system messages for IMS ISC sessions are logged and routed directly to the IMS master terminal operator when no PRN is supplied using the input ATTACH parameters. If a PRN value is supplied for IMS ISC sessions, it becomes the IMS input message destination transaction code or LTERM name (message switch), and the input system message is passed to ISC edit. SYSMMSG does not provide access to the IMS command processor.

A reply can result from the input SYSMMSG if a PRN value supplied is for an IMS transaction. This reply is sent just as is any other (non-SYSMSG) asynchronous output message.

IMS requests attachment of the SYSMMSG process to send IMS broadcast and other system messages that are not directly solicited by an input IMS command.

## ATTACH Parameters with the IMS SYSMMSG Process

**Exception:** When IMS detects an error condition during an input IMS response mode or conversational transaction, an exception response (selective receiver ERP) to the input transaction occurs and the system message is sent as an ERP message.

The following examples, shown in Figure 69 and Figure 70, illustrate the use of the ATTACH parameters when attaching the SYSMMSG process for IMS input and output messages.

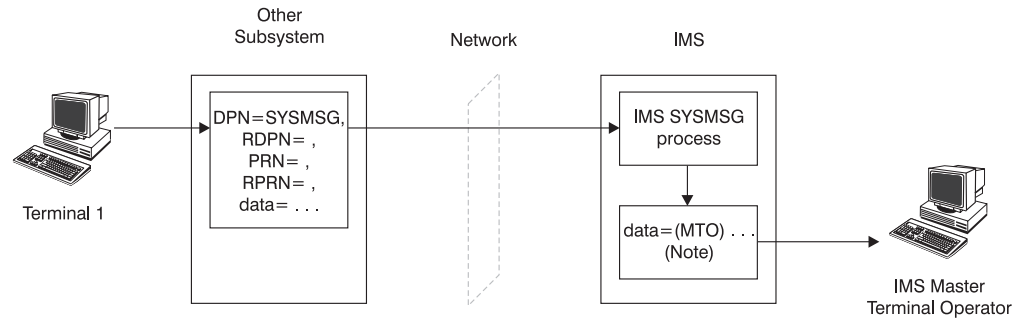

Figure 69. Example 1: SYSMMSG without PRN from Other Subsystem Terminal to IMS A

**Note:** The IMS LTERM name for the master terminal operator is assumed when no input ATTACH PRN parameter is supplied.

In Figure 70, the input message from Terminal 1 is routed from a non-IMS subsystem to the IMS SYSMMSG process in IMS using ATTACH parameters. The IMS SYSMMSG process passes the message to the IMS edit process, which sends the data to tran1 in the IMS MPP region. After tran1 processes, the reply is passed to the IMS edit process again, which uses SCHEDULER parameters to send the reply back to Process 1 and then Terminal 1 on the other subsystem.

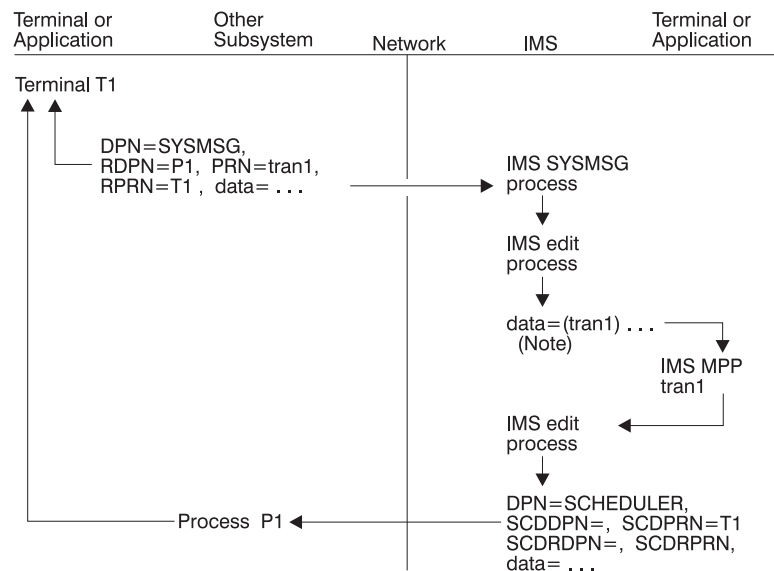

Figure 70. Example 2: SYSMMSG with PRN from another Subsystem Terminal to IMS

**Note:** The PRN parameter becomes the IMS destination. The input RDPN and RPRN parameters become the output DPN and PRN parameters respectively for any resulting reply from the MPP.

## ATTACH and SCHEDULER Parameters with IMS MFS

The following examples—shown in Figure 71, Figure 72 on page 530, Figure 73 on page 531, Figure 74 on page 532, and Figure 74 on page 532—illustrate the use of the ATTACH and SCHEDULER parameters when using IMS MFS for IMS input and output messages.

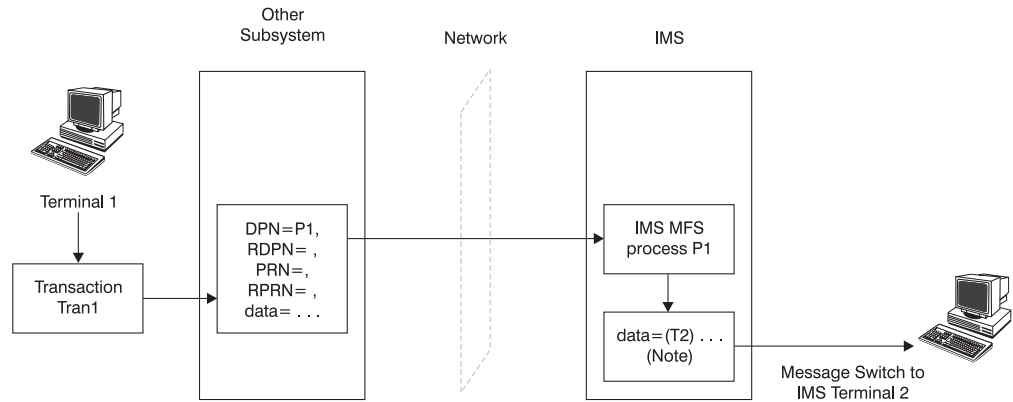

Figure 71. Example 1: Message Switch from Other Subsystem Terminal to IMS Terminal

**Note:** The IMS LTERM name for terminal T2 can be supplied as the input primary resource name (PRN), as a data field, or as an MFS-defined literal. RPRN and RDPN, if supplied, can be optionally included in the data presented to the IMS terminal by MFS. The DPN parameter must be supplied in the input ATTACH FM header to invoke MFS.

In Figure 72 on page 530, a transaction message originates from Terminal 1 and is sent to Process P1 on a non-IMS subsystem. The ATTACH parameters are then used to send the message to the MFS process P2 on the IMS subsystem. The MFS process P2 sends the message to Tran2 in the MPP region. The reply from the MPP region is sent back to the MFS process, which uses the ATTACH parameters to send the reply to the other subsystem. The other subsystem allocates Terminal 1 as a resource of Transaction Tran1 and the message is sent back to the terminal.

## ATTACH and SCHEDULER Parameters with IMS MFS

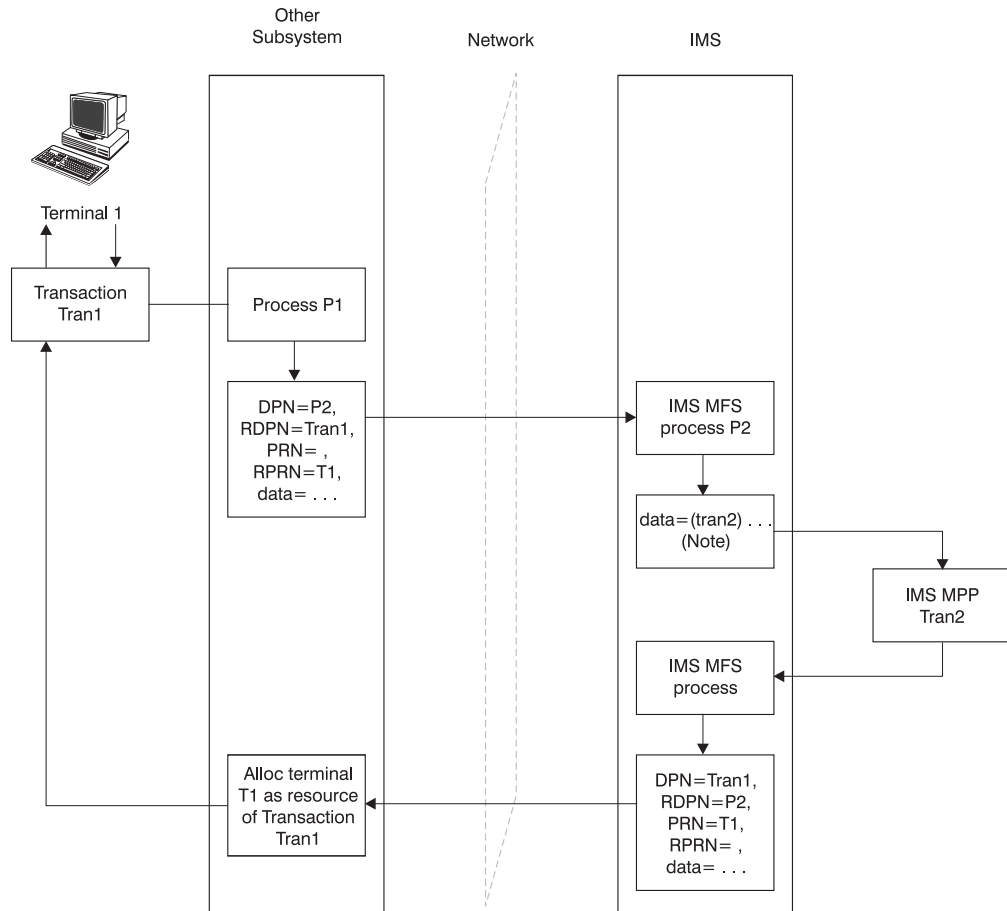

Figure 72. Example 2: Other Subsystem Terminal Accesses IMS Application Program with Reply

**Note:** The IMS transaction code can be supplied as the input PRN, as a data field (first field for basic edit), or as an MFS-defined literal. The DPN parameter must be supplied to invoke IMS MFS DPM. If a reply inserted by the MPP is processed by MFS, the DPM process might create or override any of the output ATTACH parameters. The input RDPN and RPRN parameters become the output DPN and PRN parameters respectively for any resulting reply from the application program if they are not overridden by the DPM process.

In Figure 73 on page 531, a transaction message originates from Terminal 1 and is sent to Process P1 on a non-IMS subsystem. The ATTACH parameters are then used to send the message to the MFS DPM process P2 on the IMS subsystem. The MFS DPM process P2 sends the message data to Tran2 in the MPP region. The reply from the MPP region is sent back to the MFS DPM process, which uses the ATTACH parameters to send the reply to the non-IMS subsystem as Tran3, which is then stored for later retrieval by Terminal 1.



## ATTACH and SCHEDULER Parameters with IMS MFS

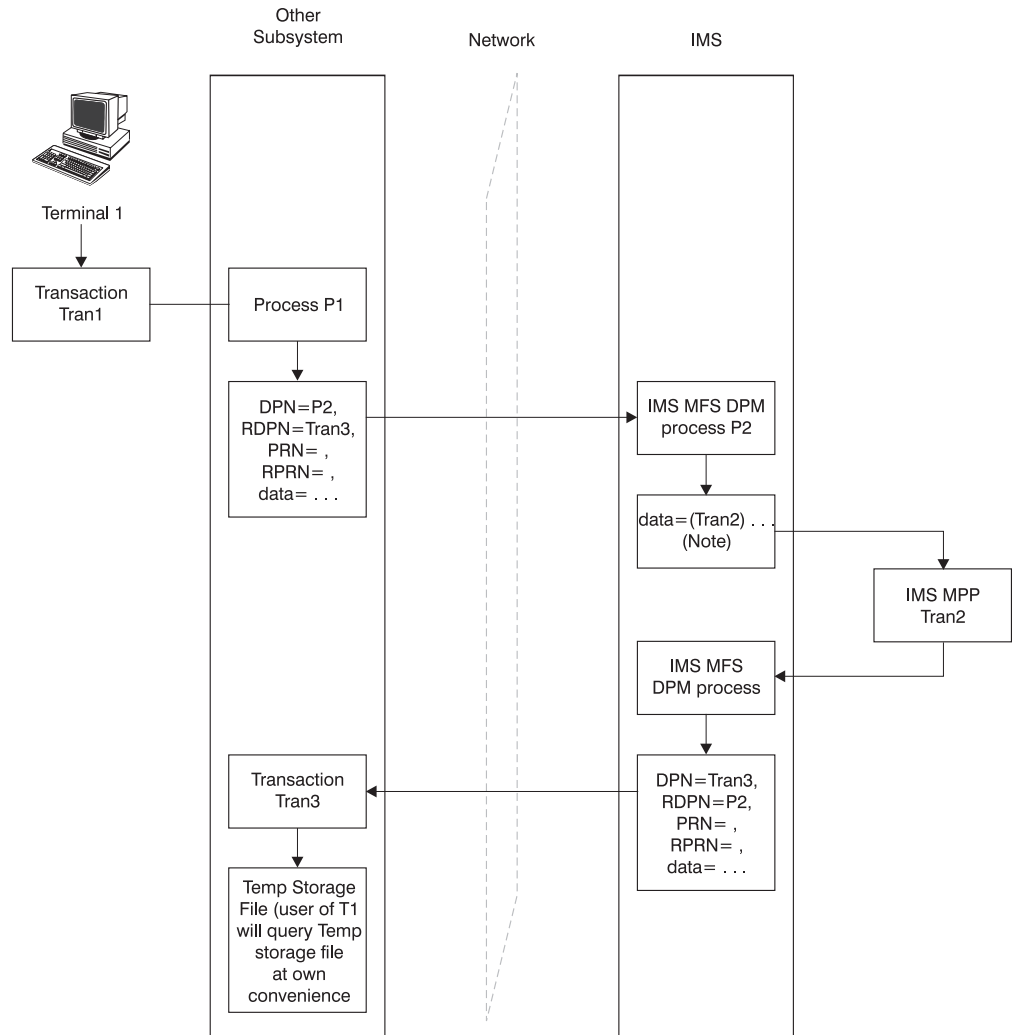

Figure 73. Example 3: IMS MPP Is Accessed from Other Subsystem Terminal with Reply to a Temporary Storage File of the Other Subsystem

**Note:** The IMS transaction code can be supplied as the input PRN, as a data field, or as an MFS-defined literal. The DPN parameter must be supplied to invoke IMS MFS DPM. If a reply is inserted by the MPP, the DPM process might override or create any of the output ATTACH parameters. The input RDPN and RPRN parameters become the output DPN and PRN parameters respectively for any resulting reply from the application program if they are not overridden by the DPM process.

## ATTACH and SCHEDULER Parameters with IMS MFS

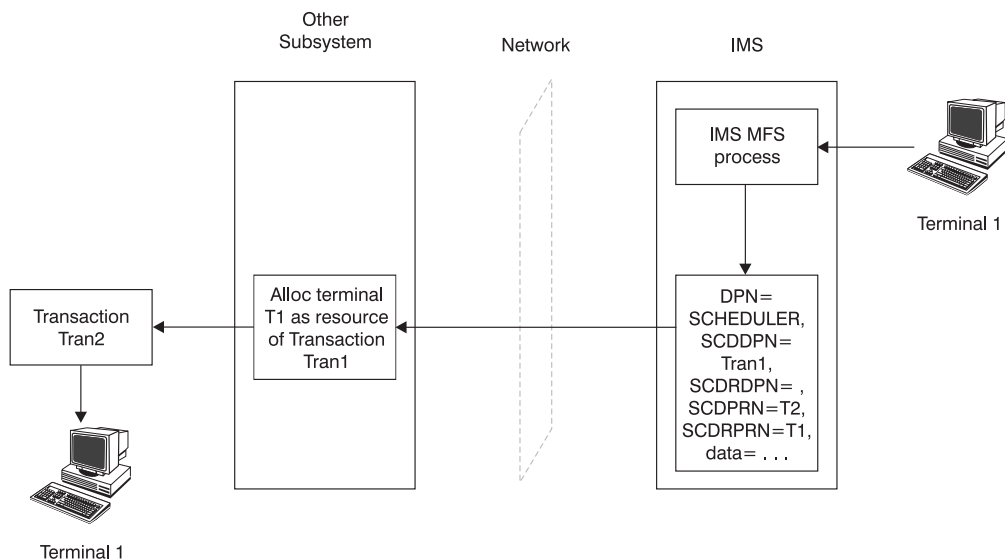

Figure 74. Example 4: Message Switch from an IMS Terminal to a Terminal on another Subsystem

MFS DPM is necessary to create the required output SCHEDULER parameters. The SCDDPN and SCDPRN can be entered as data from the terminal or application program. If a reply is returned to another IMS terminal or application program, the default SCDRPRN parameter can be overridden within the IMS output message's SCHEDULER FM header to specify the suggested IMS terminal or application to receive that reply. The reply is returned with this value in the SCDPRN field.

In Figure 75 on page 533, messages are routed from IMS Terminal 1 to the IMS MFS process either through a message switch or through an MPP or Fast Path message routing application. The MFS process P2 sends the message with SCHEDULER parameters to a transaction on another subsystem. The other subsystem then sends the reply message back using similar SCHEDULER parameters to IMS and the MFS process P2. The MFS edit process directs the message back to Terminal 1.

## ATTACH and SCHEDULER Parameters with IMS MFS

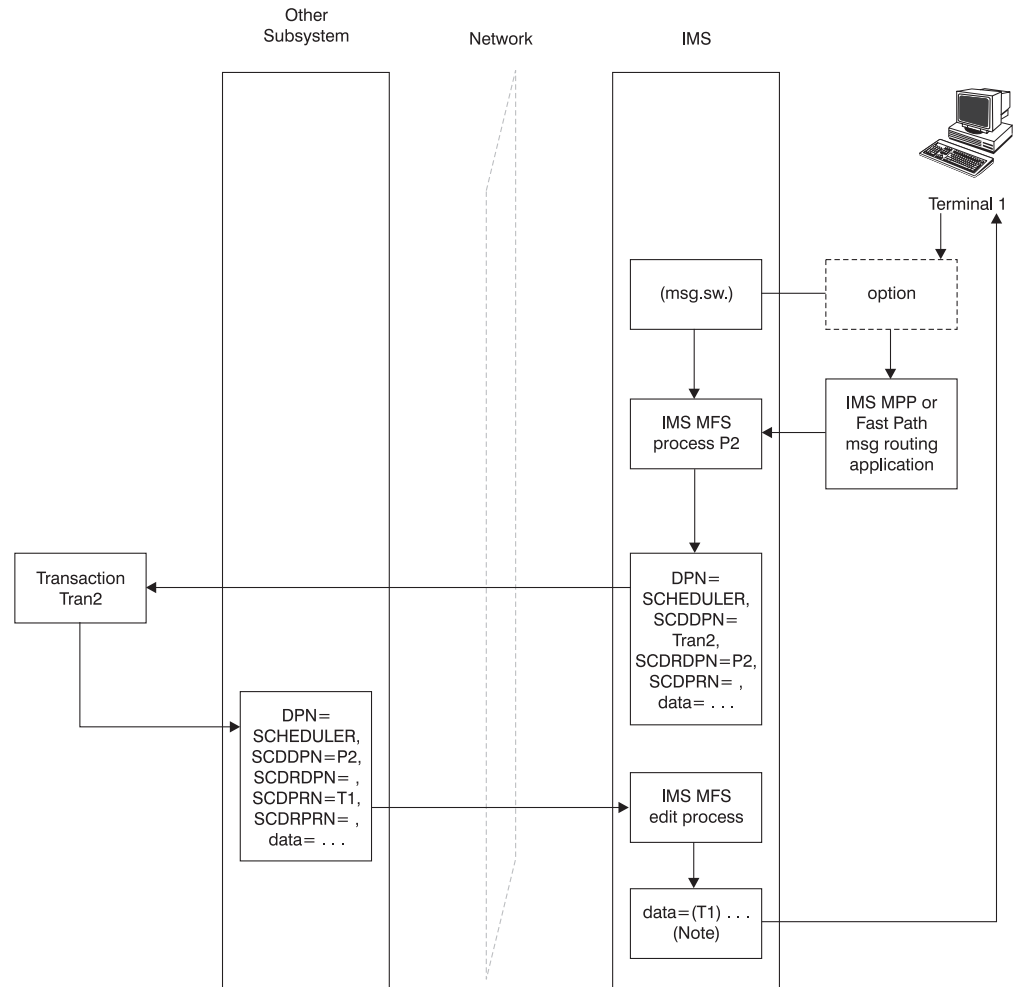

Figure 75. Example 5: Message Routing

**Note:** The IMS LTERM name can be supplied as the input SCDPRN, as the first data field, or as an MFS-defined literal. The SCDDPN parameter must be supplied to invoke IMS MFS. MFS can override or create any of the output SCHEDULER parameters.

## ATTACH and SCHEDULER Parameters with IMS MFS

---

## Appendix G. How IMS and CICS Use the ISC Interface

This appendix describes some of the issues involved when designing and implementing an ISC network that contains both IMS and CICS nodes. Before reading this appendix, you should be familiar with the basic system design concepts of both IMS and CICS running in a VTAM environment. The CICS information provided here is for planning purposes.

**Related Reading:** For more information on the design and coding of a CICS application that communicates with IMS through LU 6.1 ISC, see *CICS Intercommunication Guide*.

### **In this Appendix:**

- “Functions Available to the ISC Session”
- “General Flow of CICS EXEC Commands within a CICS Application” on page 539
- “Coding Asynchronous Messages” on page 543
- “Commands That Should Not Be Used on an ISC Session” on page 546
- “Selecting Appropriate CICS Installation Options for ISC” on page 546
- “Coding CICS System Definition Options” on page 546
- “Preparing CICS Resource Definition” on page 547
- “Defining IMS-CICS LU 6.1 Links” on page 547
- “Defining Compatible IMS and CICS Nodes” on page 548
- “Defining Multiple Links to an IMS System” on page 552
- “Defining CICS Transactions for IMS-CICS ISC” on page 554
- “Application-Related Concepts” on page 557
- “Coding Function Management Headers for CICS” on page 564
- “Recovery and Restart Concepts” on page 570
- “Handling Transaction Abends” on page 575
- “Coding CICS Applications for Restart” on page 576

---

## Functions Available to the ISC Session

### **Definitions:**

- In *synchronous mode* in an ISC session, the session is held between the moment a request is entered and the moment a reply is returned. Thus, a direct correlation can be made between the input request and the output reply.
- In *asynchronous mode* in an ISC session, no correlation can be made between an input request and an output reply. No assumptions can be made as to the timing of the output reply or the availability of any other output for that session.

**Related Reading:** For more information on these terms in the context of an ISC session, see “Relationship of ISC and IMS Execution Modes” on page 272.

The special support for front-end/back-end system utilization provided by the Front-End Switch exit routine uses ISC in asynchronous mode.

## Functions Available to the ISC Session

**Related Reading:** For information on the Front-End Switch exit routine (DFSFEJ0), see *IMS Version 9: Customization Guide*.

CICS implements ISC using its Command Level (EXEC) application programming interfaces (APIs). CICS has two VTAM APIs: synchronous and asynchronous. The synchronous API uses the SEND/RECEIVE EXEC commands; the asynchronous API uses the START/RETRIEVE EXEC commands. When used within the context of a CICS application program, the EXEC commands create the SNA data flow control protocols for synchronous or asynchronous processing that are associated with messages on the session.

The CICS implementation is quite different from IMS, in which the data flow control protocols sent with a message are created by the system and based on:

- Whether the attributes (such as recoverability and segmentation) are defined for the message on the TRANSACT, TERMINAL, and SUBPOOL macro statements during IMS system definition or on an ETO logon descriptor
- Whether the characteristics are defined in the bind parameters
- Whether the message is a reply that is returned on the same session as an associated request or on a different session than the associated request
- Whether the message is unsolicited asynchronous output

**Related Reading:** For more information on these factors, see “Relationship of ISC and IMS Execution Modes” on page 272.

This topic identifies synchronous and asynchronous command sequences available to the CICS application.

CICS SEND/RECEIVE commands create the predefined SNA protocols associated with synchronous processing when SEND is used with the INVITE option. SEND INVITE causes an SNA ATTACH function management header and change-direction to be issued with the message. The message is sent from CICS to the remote IMS subsystem for processing. When the message reply is returned, it is processed by a RECEIVE command issued within the same CICS transaction that issued the first message.

**Exception:** Restarted transactions are handled differently; for information, see “Recovery and Restart Concepts” on page 570.

When the SEND command is used with the LAST option, it causes the message to be sent on the session with an ATTACH function management header and carries both begin-bracket and end-bracket (BB/EB) status. IMS treats this special case of synchronous processing in the same way as an IMS asynchronous transaction is treated. If IMS generates an output reply as a result of an input generated with SEND LAST, the returned reply can be processed by a newly initiated CICS transaction. The IMS output reply is also sent with ATTACH BB/EB. CICS uses RECEIVE to process that reply.

The START/RETRIEVE commands create the SNA protocols associated with asynchronous processing. A START command causes an SNA ATTACH function management header and a concatenated SCHEDULER function management header to be issued with the message. Messages sent to IMS with the START command can be only one chain in length and are sent with BB/EB. CICS uses the RETRIEVE command to obtain asynchronous messages from the session for CICS transaction processing. The other SNA data flow control protocols issued with an asynchronous message depend upon the type of message issued. When an

## Functions Available to the ISC Session

asynchronous message is sent from CICS to IMS, the sending transaction might terminate. The returned reply can be processed by a newly initiated CICS transaction according to parameters in the function management headers returned on the message by IMS. Figure 76 illustrates the concept of SEND/RECEIVE processing.

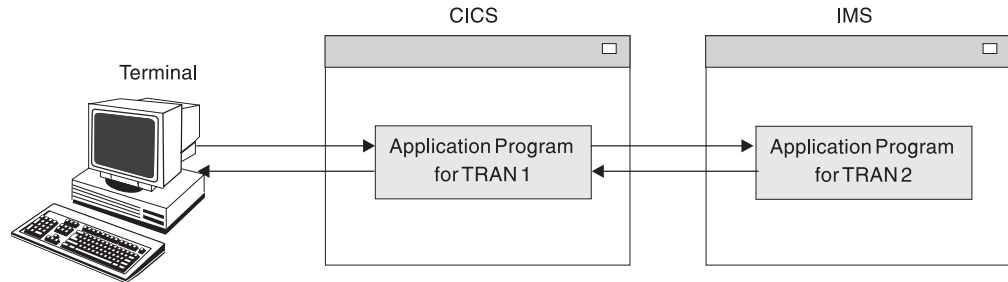

Figure 76. SEND/RECEIVE (Synchronous) Processing

Figure 77 illustrates the concept of START/RETRIEVE processing.

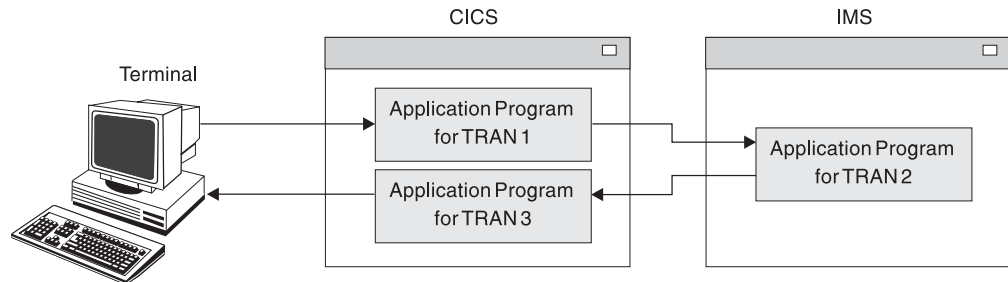

Figure 77. START/RETRIEVE (Asynchronous) Processing

Table 78, Table 79 on page 538, and Table 80 on page 538 summarize the functions available to a session between IMS and CICS. You must know whether the flow on a session is to be synchronous or asynchronous in order to determine what functions are available to that session. See the notes following the tables for further explanations.

The tables do not take into consideration the recovery aspects of any of the listed combinations. A “Yes” indicates only that the approach is possible. However, a system designer should take into account the need for ease of recovery and restart.

Table 78. Functions Available to an IMS-CICS Session for CICS EXEC Commands: CICS Front End

Functions Available	SEND(INVITE)/ RECEIVE (Synchronous)	SEND(LAST) (Synchronous)	START/ RETRIEVE <sup>1</sup> (Asynchronous)
Nonresponse or nonconversational mode IMS input transaction	No	Yes	Yes
Nonresponse or nonconversational mode IMS output transaction	Yes <sup>2</sup>	N/A	Yes
Response mode IMS transaction (including Fast Path)	Yes <sup>3</sup>	No	No

## Functions Available to the ISC Session

Table 78. Functions Available to an IMS-CICS Session for CICS EXEC Commands: CICS Front End (continued)

Functions Available	SEND(INVITE)/ RECEIVE (Synchronous)	SEND(LAST) (Synchronous)	START/ RETRIEVE <sup>1</sup> (Asynchronous)
Conversational mode nonlast IMS input transaction	yes	No <sup>4</sup>	No
Conversational mode last IMS input transaction	No	No <sup>4</sup>	Yes
IMS message switch	No	Yes	Yes
IMS operator command	Yes <sup>5</sup>	Yes <sup>6</sup>	Yes <sup>6</sup>
Recoverable <sup>7</sup> IMS transaction	N/A	N/A	N/A
Nonrecoverable <sup>7</sup> IMS transaction	N/A	N/A	N/A
Single-segment input/output IMS transaction	Yes	Yes	Yes
Multi-segment input/output IMS transaction	Yes	Yes	No

Table 79. Functions Available to an IMS-CICS Session for CICS EXEC Commands: IMS Front End

Functions Available	SEND(INVITE)/ RECEIVE (Synchronous)	SEND(LAST) (Synchronous)	START/ RETRIEVE <sup>1</sup> (Asynchronous)
CICS transaction	No	No	Yes
CICS operator command (system transaction)	No	No	No

Table 80. Functions Available to an IMS-CICS Session for CICS EXEC Commands: MFS and BMS Support

Functions Available <sup>8</sup>	SEND(INVITE)/ RECEIVE (Synchronous)	SEND(LAST) (Synchronous)	START/ RETRIEVE <sup>1</sup> (Asynchronous)
Without IMS MFS	Yes	Yes	Yes
MFS without paging	Yes	Yes	Yes
MFS autopaged input	Yes <sup>9</sup>	Yes <sup>9</sup>	No
MFS autopaged output	Yes <sup>10, 2</sup>	N/A	No
MFS demand-paged output	Yes	N/A	No <sup>11</sup>
BMS support <sup>8</sup>	N/A	N/A	N/A

### Notes for CICS EXEC Tables:

1. Single-chain messages only.
2. The nonresponse-mode reply to a transaction sent with SEND LAST is sent ATTACH BB/EB. CICS uses RECEIVE (without SEND) to obtain the message from the session. (See "CICS to IMS Using the SEND LAST EXEC Command" on page 541.)



3. IMS forces response mode regardless of system definition if a transaction is specified externally (using the function management header) as synchronous. See “Relationship of ISC and IMS Execution Modes” on page 272.
4. IMS conversational mode requires that IMS terminate the conversation by sending the last reply with EB. The exception to this is explained in “CICS versus IMS Conversation Mode” on page 560.
5. The replies that result from the IMS /DISPLAY, /FORMAT, and /RDISPLAY commands are sent asynchronously after IMS replies synchronously to the input command.
6. Supported only for /DISPLAY, /RDISPLAY, and /FORMAT.
7. A transaction is defined as recoverable or nonrecoverable during IMS system definition and is acceptable to IMS only when the sync point protocols and transaction definitions are consistent. See “Relationship of ISC and IMS Execution Modes” on page 272 and “Keeping Half Sessions Synchronized” on page 321 for more information.
8. MFS maps data between the session and the IMS application program. BMS maps data at the request of the CICS application program. BMS does not interact with the session, but can be used to handle mapping of data to and from IMS. IMS’s MFS and CICS’s BMS do not communicate.
9. Both single- and multiple-message chains can be used, but only one chain can occur per SEND.
10. To avoid tying up the session, when processing synchronous autopaged output from IMS, CICS should read all pages of the IMS output before processing it.
11. Although demand paging is possible between IMS and CICS, it is not recommended, because it requires complex CICS application coding and a complex terminal user interface. A preferable approach is to create autopaged output from IMS to CICS and use CICS page retrieval in the local system for paging.

---

## General Flow of CICS EXEC Commands within a CICS Application

The design of a CICS application program using the CICS EXEC command level application programming interfaces is determined by whether the transaction being sent on the ISC session is to be processed using SEND/RECEIVE, SEND LAST, or START/RETRIEVE. The sequence of EXEC commands issued is determined by whether the transaction is defined as recoverable or nonrecoverable. Program design can also depend on whether CICS is the front-end system (initiating a transaction) or back-end system (replying to an IMS transaction).

This topic presents an overview of synchronous and asynchronous transaction processing flow within CICS. As such, it supplements the overview information provided in “Functions Available to the ISC Session” on page 535. Understanding the content and functions of the ATTACH and SCHEDULER FM headers is helpful in understanding this topic.

**Related Reading:** For information on the ATTACH and SCHEDULER FM headers, see “Coding Function Management Headers for CICS” on page 564.

## CICS to IMS Using SEND/RECEIVE EXEC Commands

In a system in which CICS is the front-end subsystem and IMS the back-end subsystem, the SEND/RECEIVE commands are used to process IMS response mode (including Fast Path) and conversational transactions, and IMS commands.

## Flow of CICS EXEC Commands within a CICS Application

The general CICS application program flow for a synchronous message from CICS to IMS is shown in Figure 78.

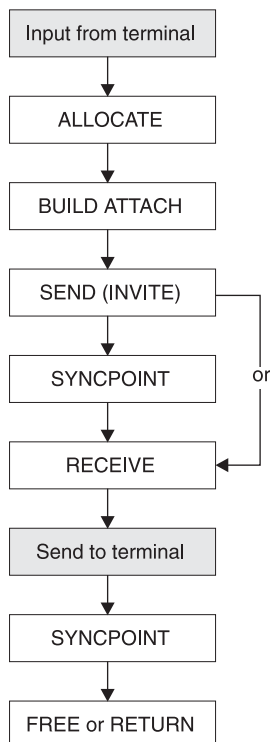

Figure 78. Application Program Flow Using SEND/RECEIVE from CICS to IMS

In this example, the CICS application reads the input message from the terminal and establishes a CICS-to-IMS session using the ALLOCATE command.

The CICS application program builds the required ATTACH function management header (the only header required, because this is a synchronous application) by using the BUILD ATTACH EXEC command. The RPROCESS and RRESOURCE fields should be specified in the BUILD ATTACH to provide for restart. Issuing SEND causes the output message to be constructed. SEND INVITE causes change-direction (CD) to be appended to the output message.

**Related Reading:** For information on using the BUILD ATTACH command and its parameters, see “Coding Function Management Headers for CICS” on page 564 and “Recovery and Restart Concepts” on page 570.

The output message is not sent across the session until the next command is executed. The next EXEC command that is issued depends upon the definition of the transaction within IMS, because this command must both append the sync-point request to the message as required and send the message across the ISC session. If this transaction is defined to IMS as recoverable, the next command must be SYNCPOINT. SYNCPOINT causes the outbound message to be sent with an RQD2. If the transaction is defined as nonrecoverable, a SYNCPOINT or a RECEIVE command can be issued next. A RECEIVE command immediately following a SEND command (without an intervening SYNCPOINT command) causes the outbound message to be issued with RQE1.

RECEIVE issued after either the SYNCPOINT or SEND commands reads the IMS reply. The reply from IMS is returned synchronously on the session (with the ATTACH

## Flow of CICS EXEC Commands within a CICS Application

FM header). If the transaction reply is to a response mode (including Fast Path) transaction, a command (except /DISPLAY, /RDISPLAY, and /FORMAT), or the last conversational reply, it is returned to CICS carrying RQD2 EB if recoverable, or RQD1 EB if nonrecoverable. If the transaction is a nonlast conversational reply, it is returned to CICS carrying RQE2 and CD (because the conversation continues).

If the transaction is defined within IMS as a nonrecoverable-inquiry, the CONVERSE command can be used. The CONVERSE command acts as if a SEND command were issued, immediately followed by a RECEIVE command. Transactions sent with a CONVERSE command carry BB/CD and a request for an exception response (RQE1). If transactions other than those defined as nonrecoverable are sent using CONVERSE, an error results.

After issuing RECEIVE, the application program must save and check the values in the EXEC interface block (EIB) before performing any additional processing. If the transaction reply is received successfully as determined by checking the EIB, the application now issues a sync point (SYNCPOINT). Issuing this sync point causes a DR2 response to be returned to the IMS transaction reply. If CICS wants to perform any application processing based upon the contents of the IMS reply message, including sending an output message to the terminal, that processing is performed before the sync point is issued. This ensures that CICS resources and IMS resources are committed in synchronism.

If the transaction completes successfully, the application program must free the session using either a FREE or RETURN EXEC command.

### CICS to IMS Using the SEND LAST EXEC Command

In a system in which CICS is the front-end subsystem and IMS the back-end subsystem, IMS supports the use of the CICS synchronous API to allow access to IMS asynchronous transactions. SEND LAST is used to process IMS nonresponse mode and nonconversational transactions, message switches, and the /DISPLAY, /RDISPLAY and /FORMAT commands.

The general CICS application program flow for CICS to IMS using SEND LAST is shown in Figure 79.

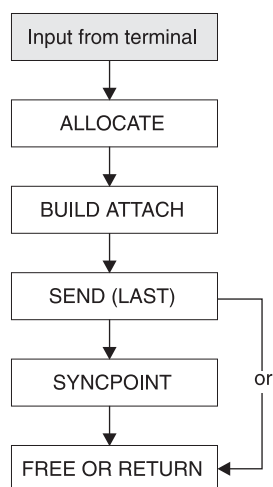

Figure 79. Application Program Flow Using SEND LAST from CICS to IMS

## Flow of CICS EXEC Commands within a CICS Application

In this example, the CICS application reads the input message from the terminal and establishes a CICS-to-IMS session using the ALLOCATE command.

The CICS application program builds the required ATTACH function management header (the only header required, because this is a synchronous application) by using the BUILD ATTACH EXEC command. The RPROCESS and RRESOURCE fields should be specified in the BUILD ATTACH to identify the terminal and transaction to be used to process the reply. Issuing a SEND command causes the output message to be constructed. A SEND LAST command causes end-bracket to be appended to the message.

**Related Reading:** For information on using the BUILD ATTACH command and its parameters, see “Coding Function Management Headers for CICS” on page 564.

The output message is not sent on the session until the next command is executed. The next EXEC command that is issued depends upon the definition of the transaction within IMS, because this command both appends the sync-point request to the message and issues the message on the ISC session. If this transaction is defined to IMS as recoverable, the next command must be SYNCPOINT. SYNCPOINT causes the outbound message to be issued with an RQD2. If the transaction is defined as nonrecoverable, either SYNCPOINT, FREE, or RETURN can be issued next. FREE or RETURN issued immediately after the SEND and without an intervening SYNCPOINT causes the outbound message to be issued with RQE1.

If IMS generates a reply message as a result of receiving this transaction, that reply from IMS is returned with the ATTACH FM header. In order to get the IMS reply message from the session, CICS must issue a RECEIVE (because the reply message carries only ATTACH).

## IMS to CICS Using the RECEIVE EXEC Command

When IMS has a reply to send to CICS that results from a message sent by CICS with SEND LAST (ATTACH BB/EB), IMS sends that message using the ATTACH function management header and BB/EB. In order to receive the message from the session, CICS must initiate a new transaction (or a new instance of the original transaction) that uses the RECEIVE EXEC command for this purpose. The general CICS application program flow for this is shown in Figure 80.

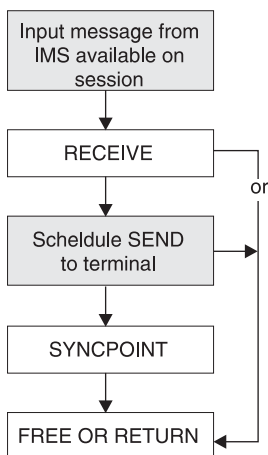

Figure 80. Application Program Flow Using RECEIVE from IMS to CICS

## Flow of CICS EXEC Commands within a CICS Application

The reply from IMS is returned synchronously on the session (with the ATTACH FM header) and carries BB/EB. A recoverable reply carries RQD2; a nonrecoverable reply carries RQD1. The RPROCESS (RDPN) and RRESOURCE (RPRN) fields sent to IMS are automatically wrapped by IMS into the DPN and PRN fields of the outbound ATTACH FMH.

CICS examines the returned reply and uses the DPN, or the first four characters of the data, to determine the transaction that can process the returned reply. RECEIVE is used to obtain the IMS reply from the session. The PRN field is passed to the initiated transaction, indicating the terminal to which the returned reply is to be sent.

After issuing RECEIVE, the application program must save and check the values in the EXEC interface block (EIB) before performing any additional processing.

CICS must schedule an asynchronous transaction to send the returned reply to the terminal by issuing a START command. The transaction that is initiated is brought up, and owns the terminal to which the reply is to be sent. This asynchronous transaction uses the START interface to communicate with the terminal, and all processing within this transaction occurs asynchronously to the transaction that initiated it. If the transaction that sends output to the terminal is scheduled successfully, the originating application now issues a sync point (SYNCPOINT), if required. Issuing this sync point causes an appropriate response to be returned to the IMS transaction reply. If the transaction is not scheduled successfully, issuing the sync point causes an appropriate exception response to be returned to the IMS transaction reply. If CICS wants to perform any application processing based upon the contents of the IMS reply message, that processing is performed before the sync point is issued. This ensures that CICS resources and IMS resources are committed in synchronism.

If the processing completes successfully, the application program must free the session using either a FREE or RETURN EXEC command.

---

## Coding Asynchronous Messages

When receiving asynchronous messages (sent with ATTACH and SCHEDULER function management headers) from IMS, CICS invokes a CICS-supplied “mirror transaction” to obtain these incoming messages from the session. The mirror transaction is CICS’s name for the SCHEDULER process. This mirror transaction examines the incoming data stream and schedules (using START) the transaction that is to be initiated as a result of the incoming DPN or the first four characters of the data. The receiving CICS transaction is assumed to be one of the following:

- ISC edit (ISCE), the default DPN set by IMS
- The transaction whose identifier was placed in the DPN field of the ATTACH FM header by IMS’s wrapping of the incoming RDPN (the RTRANSID specified on the CICS START)
- A transaction whose identifier has been supplied by an MFS MOD

CICS uses the PRN in the incoming message as the TERMID parameter of the START command so that the transaction is initiated and owns the CICS terminal (if applicable) to which this message should be written.

A SYNCPOINT command is now issued to return the appropriate response to IMS and to complete the scheduling of the asynchronous transaction. Following the

## Coding Asynchronous Messages

sync point, a RETURN command is issued to terminate the transaction and free the session. The response returned to IMS causes the output asynchronous message to be dequeued from the IMS output queue.

### CICS to IMS Using the START/RETRIEVE EXEC Commands

CICS uses START/RETRIEVE commands to process IMS nonresponse mode and nonconversational transactions, message switches, and the /DISPLAY, /RDISPLAY, and /FORMAT commands. The general CICS application program flow for an asynchronous message from CICS to IMS is shown in Figure 81.

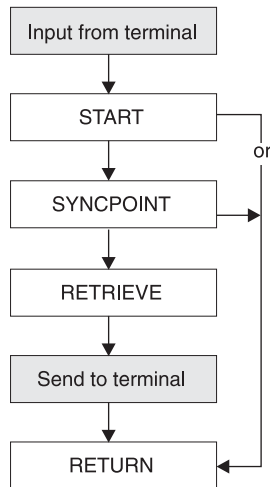

Figure 81. Application Program Flow Using START/RETRIEVE from CICS to IMS

After the input message is received from the terminal, the transaction is assembled using the START command. The values to be contained in the ATTACH and SCHEDULER function management header DPN, PRN, RDPN, and RPRN fields are specified as parameters on the START command. The DPN and PRN are used by IMS to determine the editing process to be initiated and the destination of the incoming message. The RDPN and RPRN are used to identify the CICS terminal and transaction to which the reply is to be returned. The START command must also specify NOCHECK if this is an IMS nonrecoverable transaction, and NOCHECK PROTECT if this is an IMS recoverable transaction. (PROTECT can optionally be used for nonrecoverable transactions.)

NOCHECK is a mandatory parameter for an ISC session with IMS. In a CICS-CICS ISC session, the use of START causes a return code reply to be sent to the initiating CICS from the receiving CICS. This return code indicates that the receiving CICS has scheduled the transaction to be executed as a result of the message it has received. This return code does not occur on an IMS-CICS session. NOCHECK informs the sending CICS that no such response is to be expected. START NOCHECK creates a message carrying BB/EB RQE1.

PROTECT, specified for recoverable transactions, delays the sending of the transaction on the session until CICS successfully takes a SYNCPOINT. Specifying START causes begin- and end-bracket (BB/EB) and the ATTACH and SCHEDULER function management headers to be appended to the outbound message. NOCHECK PROTECT requests a definite response (RQD2).

A SYNCPOINT command is now issued to append the appropriate sync point protocols and to send the message on the session. If this transaction elects to wait

for a reply, it issues a RETRIEVE command. If this transaction does not choose to wait for a reply, it can terminate by issuing RETURN following either the START command or the SYNCPOINT command. The CICS mirror transaction schedules a new instance of this transaction when a reply is received.

If the transaction chooses to wait for the reply, it can issue RETRIEVE with or without the WAIT parameter. Issuing RETRIEVE without the WAIT parameter causes CICS to check for any queued asynchronous input for this transaction and terminal. If such input is immediately available, it satisfies the RETRIEVE command. If no such input is immediately available, an appropriate indication is returned to the RETRIEVE command, and the application can then perform other processing or issue RETURN to terminate.

If RETRIEVE WAIT is issued, CICS does not return control to the application program until an asynchronous message is sent from IMS destined for this transaction and this terminal. Using WAIT causes the terminal be held until an IMS reply is received for it.

In both cases (RETRIEVE with or without WAIT), when a message is sent from CICS to IMS requesting asynchronous processing, no assumptions can be made by the originating application as to the timing of the output reply or the availability of any other output. That is, if unsolicited asynchronous output is pending for CICS, this output can be sent to CICS before the reply to this asynchronous transaction is returned. Therefore, requests and replies are not correlated within CICS in an asynchronous environment. Issuing RETRIEVE obtains any reply from IMS on any session that has the indicated transaction and terminal identification.

### IMS to CICS Using the RETRIEVE EXEC Command

Figure 82 illustrates the general CICS application program flow in asynchronous mode from IMS to CICS.

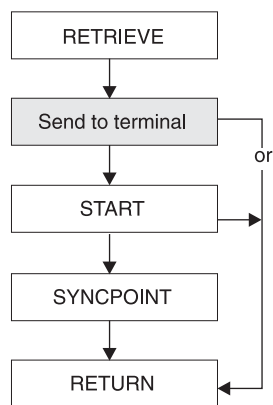

Figure 82. Application Program Flow Using RETRIEVE from IMS to CICS

Replies resulting from previous asynchronous input transactions and unsolicited asynchronous output from an IMS front-end to a CICS back-end are sent to CICS asynchronously (that is, with the ATTACH and SCHEDULER FM headers). When IMS is the front-end subsystem, asynchronous mode is the only flow supported. The CICS mirror transaction obtains the input, analyzes the incoming message, and schedules (using START) the transaction that is to be initiated as a result of the incoming DPN or the first four characters of the data. If this transaction is sending output to a terminal, the mirror transaction issues the START with the TERMID

## Coding Asynchronous Messages

parameter (from the PRN parameter of the incoming FMH), so that the asynchronous transaction that is scheduled owns the terminal to which output is to be sent.

If a reply to IMS is required, the CICS application must wrap the incoming RTERMID and RTRANSID into the TERMID and TRANSID fields to be used in a subsequent START. These fields indicate, respectively, the destination LTERM or transaction within IMS and the IMS editor or MFS MID that is to receive the message. The START command to send this reply to IMS is processed.

### **Related Reading:**

- For an explanation of the content of the TERMID and TRANSID fields, see “Coding Function Management Headers for CICS” on page 564.
- For information on the processing of the START command to send the reply to IMS, see “CICS to IMS Using the START/RETRIEVE EXEC Commands” on page 544.

If no reply to IMS is required, RETURN can be issued to terminate the session.

---

## Commands That Should Not Be Used on an ISC Session

Do not use the following commands on an ISC session:

- WAIT SIGNAL  
The WAIT SIGNAL command cannot be used in a CICS-IMS session.
- WAIT TERMINAL  
The WAIT TERMINAL command is not normally used in a CICS-IMS ISC session.

---

## Selecting Appropriate CICS Installation Options for ISC

This topic describes only those system definition options and resource definition options that have unique considerations for an IMS-CICS ISC environment.

Some of the parameters coded during the CICS installation process must be compatible with some of the IMS system definition parameters coded on the IMS system definition macros. The topic “Defining Compatible IMS and CICS Nodes” on page 548 brings together the definitions provided here with the IMS system definition information provided in “Statically Defining an ISC Node to IMS” on page 291.

---

## Coding CICS System Definition Options

The CICS standard pregenerated system as supplied on the distribution tape includes a pregenerated version for each of the CICS management modules required to support an Intersystem Communication environment that includes all of the required system definition options.

### **Related Reading:**

- For information on system definition, see *CICS Intercommunication Guide* for the specifications necessary to generate a CICS subsystem that participates in IMS-CICS Intersystem Communication.
- For a checklist of recovery options, see *CICS Recovery and Restart Guide*.



## Preparing CICS Resource Definition

CICS user-created tables and Resource Definition Online (RDO) describe the database and data communications environment, and the treatment of the elements in that environment. They contain information about terminals, files, databases, programs, transactions, transient data destinations, and temporary storage data identifiers. They are created independently of system definition, but must be present for the system to be operational. The CICS System Log and Dynamic Log, which are optional in some CICS environments, are required for IMS-CICS ISC.

### Related Reading:

- For more information on table preparation and RDO options, see the *CICS Resource Definition Guide*.
- For a summary of the parameters required for IMS-CICS Intersystem Communication, see *CICS Intercommunication Guide*.
- For a checklist of recovery-related options, see *CICS Recovery and Restart Guide*.

## Defining IMS-CICS LU 6.1 Links

A CICS link to an IMS system requires a definition of the connection (or system) and a separate definition of each of the sessions. Resource Definition Online or Macro-Level Resource Definition can be used to define an ISC link to IMS. IMS-CICS ISC links are implemented with LU 6.1 protocol.

Table 81 shows the RDO form of definition for individual LU 6.1 sessions, and shows the macro form for how the operands are related.

The TRMTYPE, TRMIDNT, SYSIDNT, NETNAMQ, and SESTYPE operands must be coded for each session that you define. The remaining operands of TYPE=TERMINAL can optionally be coded on the TYPE=SYSTEM macro to provide defaults for all the defined sessions. Also, the CONNECT, DATASTR, and RECFM operands of TYPE=SYSTEM can be coded for individual sessions, if required.

Table 81. Defining an LU 6.1 Link with Individual Sessions

RDO Definition	Macro-Level Definition
DEFINE	DFHTCT TYPE=SYSTEM
CONNECTION(sysidnt)	,SYSIDNT=sysidnt)
GROUP(groupname)	
NETNAME(name)	,NETNAME=name
ACCESSMETHOD(VTAM)	,ACCMETH=VTAM)
PROTOCOL(LU61)	
DATASTREAM(USER 3270	,DATASTR=({USER 3270
SCS STRFIELD	SCS STRFIELD
LMS)	LMS})
RECORDFORMAT(U VB)	,RECFM={U VB}
AUTOCONNECT(NO YES)	[,CONNECT=AUTO ALL]
SECURITYNAME(name)	,XSNAME=name
INSERVICE(YES)	

## Defining IMS-CICS LU 6.1 Links

Table 81. Defining an LU 6.1 Link with Individual Sessions (continued)

RDO Definition	Macro-Level Definition
<b>Each individual session is then defined as follows:</b>	<b>Each individual session is then defined as follows:</b>
DEFINE SESSIONS(csdname) GROUP(groupname) SESSNAME(name) CONNECTION(sysidnt) NETNAMEQ(name) PROTOCOL(LU61) SENDCOUNT(0 1) RECEIVECOUNT(1 0) SENDSIZE(size) RECEIVESIZE(size) BUILDCHAIN(N Y) OPERID(operator-id) OPERPRIORITY(number) OPERRSL(number) OPERSECURITY(number) IOAREALEN(value) SESSPRIORITY(number)	DFHTCT TYPE=TERMINAL  ,TERMIDNT=name ,SYSIDNT=sysidnt ,NETNAMQ=name ,TRMTYPE=LUTYPE6 ,SESTYPE= SEND RECEIVE  ,BUFFER=size ,RUSIZE=size ,CHNASSY={NO YES} ,OPERID=operator-id ,OPERPRI=number ,OPERRSL=number ,OPERSEC=number ,TIOAL=value ,TRMPRTY=number ,TRMSTAT=TRANSCIVE

## Defining Compatible IMS and CICS Nodes

To define IMS-CICS ISC links, you should understand the relationship between the way remote systems and sessions are defined in CICS and the way they are defined in IMS.

The relationships between CICS and IMS definitions are summarized in Table 82 on page 551 (RDO) and in Table 83 on page 552 (macro-level definition).

RDO terms are used in the following explanation of the compatibility requirements. See Table 81 on page 547 for the equivalent macro-level operands.

The following topics provide additional information:

- “System Names”
- “Number of Sessions” on page 549
- “Session Names” on page 549
- “Other Session Parameters” on page 549

## System Names

The network name of the CICS system is specified in the APPLID operand of the DFHSIT macro. (It can be provided as an override during CICS startup or in the APPLID operand of the DFHTCT TYPE=INITIAL macro.) This name must be specified in the NAME operand of the TERMINAL macro or on the ETO logon descriptor that defines the CICS system. This name must be known to the IMS master terminal operator as it is required to be specified within those IMS master terminal operator commands (for example, /OPNDST) that reference sessions between IMS and CICS.

The network name of the IMS system is specified in the APPLID operand of the IMS COMM macro. You must specify this name in the NETNAME operand of the DEFINE CONNECTION command that defines the IMS system.

## Number of Sessions

For statically defined terminals in IMS, the number of parallel sessions that are required between the CICS and IMS system must be specified in the SESSION operand of the IMS TERMINAL macro. Each session is then represented by a SUBPOOL entry in the IMS VTAMPOOL. In CICS, each of these sessions is represented by an individual session definition.

## Session Names

**Definition:** Each CICS-IMS session is uniquely identified by a *session-qualifier pair*, formed from both the CICS and IMS session names.

The CICS session name is specified in the SESSNAME operand of the DEFINE SESSIONS command. For sessions that are to be initiated by IMS, this name must correspond to the ID parameter of the IMS /OPNDST command for the session. For sessions initiated by CICS, the name is supplied on the CICS /OPNDST command and is saved by IMS.

The IMS session name is specified in the NAME operand of the IMS SUBPOOL macro. You must make the relationship between the session names explicit by coding this name in the NETNAMEQ operand of the corresponding DEFINE SESSIONS command.

**Recommendation:** For operational convenience, use the same CICS and IMS names for a session.

## Other Session Parameters

This topic lists the remaining operands of the DEFINE CONNECTION and DEFINE SESSIONS commands that are of significance for CICS-IMS sessions.

### SENDSIZE

- If CICS is the *primary* half session, specifies the maximum request unit (RU) that CICS sends to the remote IMS system. This value must be less than or equal to the value specified by the RECANY parameter in the IMS COMM macro.
- If CICS is the *secondary* half session, specifies the maximum RU that CICS receives from the remote IMS system. This value must be less than or equal to the value specified by the OUTBUF parameter in the IMS TERMINAL macro.

### RECEIVESIZE

- If CICS is the *primary* half session, specifies the maximum request unit (RU) that CICS receives from the remote IMS system. This value must be less than or equal to the value specified by the OUTBUF parameter in the IMS TERMINAL macro.
- If CICS is the *secondary* half session, specifies the maximum RU that CICS sends to the remote IMS system. This value must be less than or equal to the value specified by the RECANY parameter in the IMS COMM macro.

### BUILDCHAIN(N|Y)

Specifies whether multiple RU chains are to be assembled before being passed to the application program. If Y is specified, a complete chain is passed to the application program in response to each RECEIVE command, and the application must perform any required deblocking. If N is specified, a single RU is passed to the application program in response to each RECEIVE command.

## Defining Compatible IMS and CICS Nodes

**Recommendation:** BUILDCHAIN(Y) is recommended, even when IMS record mode (VLVB) is used, because the logical records produced as IMS output might not coincide with RU boundaries.

### DATASTREAM(USER)

Specifies a data stream profile when CICS is communicating with IMS using the START command (asynchronous processing). CICS messages generated by the START command always cause IMS to interpret the data stream profile as input for component 1. This parameter is required.

**Related Reading:** For more information on component determination, see “LTERM Users (Subpools) and Components” on page 274.

The data stream profile for distributed transaction processing can be specified by the application program using the DATASTR option of the BUILD ATTACH command.

### RECORDFORMAT(U|VB)

Specifies the type of chaining that CICS is to use for transmissions that are initiated by START commands (asynchronous processing) on a particular session.

Two types of data handling algorithms are supported between CICS and IMS:

- Chained  
Messages are sent as SNA chains. The user can use private blocking and deblocking algorithms. This format corresponds to RECORDFORMAT(U). When IMS is the receiver, a chain of RUs is interpreted as the complete single-segment message.
- Variable length variable blocked records (VLVB)  
Messages are sent in variable-length variable-blocked format with a halfword length field before each record. This format corresponds to RECORDFORMAT(VB). When IMS is the receiver, the input deblocked element is treated as the input segment.

The data stream format for distributed transaction processing can be specified by the application program using the RECFM option of the BUILD ATTACH command.

### SENDCOUNT and RECEIVECOUNT

These operands are used to specify whether the session is a SEND session or a RECEIVE session. (In macro-level definition, this is specified in the SESTYPE=SEND|RECEIVE operand.)

A SEND session is one in which the local CICS is secondary and is the contention winner. It is specified by:

```
SENDCOUNT(1)  
RECEIVECOUNT(0)
```

A RECEIVE session is one in which the local CICS is primary and is the contention loser. It is specified by:

```
SENDCOUNT(0)  
RECEIVECOUNT(1)
```

**Recommendation:** SEND sessions are recommended for all CICS-IMS sessions.

You need not specify a SENDPFX or a RECEIVEPFX; the name of the session is taken from the SESSNAME operand.

## Defining Compatible IMS and CICS Nodes

Table 82 shows the relationship between the CICS Resource Definition Online and IMS definitions of an ISC link. Related operands are shown by numbers. If CICS is communicating with an XRF IMS, NETNAME(SYSIMS) should be the USERVAR or MNPS ACB associated with the XRF IMS.

Table 82. Defining Compatible CICS and IMS Nodes: RDO

CICS	IMS
DFHIST TYPE=CSECT ,SYSIDNT=CICL ,APPLID=SYSCICS <b>1</b>	COMM APPLID=SYSIMS <b>2</b> RECANY= <i>mmm</i> + 22 <b>7</b> EDTNAME=ISCEDT
DEFINE CONNECTION(IMS) <b>3</b> GROUP( <i>group_name</i> ) NETNAME(SYSIMS) <b>2</b> ACCESSMETHOD(VTAM) PROTOCOL(LU61) DATASTREAM(USER)	TYPE UNITYPE=LUTYPE6 <b>4</b>  TERMINAL NAME=SYSCICS <b>1</b> SESSION=2 COMPT1= COMPT2= OUTBUF= <i>nnn</i> <b>8</b>
DEFINE SESSIONS( <i>csdname</i> ) GROUP( <i>group_name</i> ) PROTOCOL(LU61) <b>4</b> SESSNAME(IMS1) CONNECTION(IMS) <b>3</b> NETNAMEQ(CIC1) <b>5</b> SENDCOUNT(1) RECEIVECOUNT(0) SENDSIZE( <i>mmm</i> ) <b>7</b> RECEIVESIZE( <i>nnn</i> ) <b>8</b> IOAREALEN( <i>nnn</i> ,16364)	VTAMPOOL  SUBPOOL NAME=CIC1 <b>5</b>  NAME CICLT1 COMPT=1  NAME CICLT1A
DEFINE SESSIONS( <i>csdname</i> ) GROUP( <i>group_name</i> ) PROTOCOL(LU61) <b>4</b> SESSNAME(IMS2) CONNECTION(IMS) <b>3</b> NETNAMEQ(CIC2) <b>9</b> SENDCOUNT(1) RECEIVECOUNT(0) SENDSIZE( <i>mmm</i> ) <b>7</b> RECEIVESIZE( <i>nnn</i> ) <b>8</b> IOAREALEN( <i>nnn</i> ,16364)	SUBPOOL NAME=CIC2 <b>9</b>  NAME CICLT2 COMPT=2

Table 83 on page 552 shows the relationship between the CICS macro-level definitions and IMS definitions of an ISC link. Related operands are shown by numbers. NETNAME=SYSIMS should be the USERVAR or MNPS ACB associated with the IMS system if you are defining a CICS to XRF IMS session.

## Defining Compatible IMS and CICS Nodes

Table 83. Defining Compatible CICS and IMS Nodes: Macro Level

CICS	IMS
DFHIST TYPE=CSECT ,SYSIDNT=CICL ,APPLID=SYSCICS <b>1</b>	COMM APPLID=SYSIMS <b>2</b> RECANY= <i>mmm</i> + 22 <b>7</b> EDTNAME=ISCEDT
DFHTCT TYPE=SYSTEM ,ACCMETH=VTAM ,SYSIDNT=IMSR <b>3</b> ,NETNAME=SYSIMS <b>2</b>	TYPE UNITYPE=LUTYPE6 <b>4</b>
DFHTCT TYPE=TERMINAL ,TRMTYPE=LUTYPE6 <b>4</b> ,TRMIDNT=IMS1 ,SYSIDNT=IMSR <b>3</b> ,NETNAMEQ=CIC1 <b>5</b> ,SESTYPE=SEND ,BUFFER= <i>mmm</i> <b>7</b> ,RUSIZE= <i>nnn</i> <b>8</b> ,TIOAL=( <i>nnn</i> ,16364) ,DATASTR=USER	TERMINAL NAME=SYSCICS <b>1</b> SESSION=2 COMPT1= COMPT2= OUTBUF= <i>nnn</i> <b>8</b>
DFHTCT TYPE=TERMINAL ,TRMTYPE=LUTYPE6 <b>4</b> ,TRMIDNT=IMS2 ,SYSIDNT=IMSR <b>3</b> ,NETNAMEQ=CIC2 <b>9</b> ,SESTYPE=SEND ,BUFFER= <i>mmm</i> <b>7</b> ,RUSIZE= <i>nnn</i> <b>8</b> ,TIOAL=( <i>nnn</i> ,16364) ,DATASTR=USER	VTAMPOOL SUBPOOL NAME=CIC1 <b>5</b> NAME CICLT1 COMPT=1 NAME CICLT1A SUBPOOL NAME=CIC2 <b>9</b> NAME CICLT2 COMPT=2

## Defining Multiple Links to an IMS System

You can define more than one intersystem link between a CICS and an IMS system by defining two or more connections (systems), with their associated session definitions, having the same NETNAME but different SYSIDs (see Table 84). Although all the system definitions resolve to the same NETNAME, and therefore to the same IMS system, using a SYSID name in CICS causes CICS to allocate a session from the link with the specified SYSIDNT.

Table 84. Defining Multiple Links to an IMS Node

RDO Definition	Macro-Level Definition
DFHSIT TYPE=CSECT ,SYSIDNT=CICL ,APPLID=SYSCICS	DFHSIT TYPE=CSECT ,SYSIDNT=CICL ,APPLID=SYSCICS
<b>CICS-Initiated Distributed Transaction Processing</b>	

## Defining Multiple Links to an IMS System

Table 84. Defining Multiple Links to an IMS Node (continued)

RDO Definition	Macro-Level Definition
<pre>DEFINE CONNECTION(IMSA)     ACCESSMETHOD(VTAM)     NETNAME(SYSIMS)</pre>	<pre>DFHTCT TYPE=SYSTEM         ,ACCMETH=VTAM         ,SYSIDNT=IMSA         ,NETNAME=SYSIMS</pre>
<pre>DEFINE SESSIONS(csdname)     PROTOCOL(LU61)     SESSNAME(IMS1)     CONNECTION(IMSA)     NETNAMEQ(DTP1)</pre>	<pre>DFHTCT TYPE=TERMINAL         ,TRMTYPE=LUTYPE6         ,TRMIDNT=IMSA         ,SYSIDNT=IMSA         ,NETNAMEQ=DTP1</pre>
<pre>DEFINE SESSIONS(csdname) : :</pre>	<pre>DFHTCT TYPE=TERMINAL : :</pre>
<b>CICS-Initiated Asynchronous Processing</b>	
<pre>DEFINE CONNECTION(IMSB)     ACCESSMETHOD(VTAM)     NETNAME(SYSIMS)</pre>	<pre>DFHTCT TYPE=SYSTEM         ,ACCMETH=VTAM         ,SYSIDNT=IMSB         ,NETNAME=SYSIMS</pre>
<pre>DEFINE SESSIONS(csdname)     PROTOCOL(LU61)     SESSNAME(IMS1)     CONNECTION(IMSB)     NETNAMEQ(ASP1)</pre>	<pre>DFHTCT TYPE=TERMINAL         ,TRMTYPE=LUTYPE6         ,TRMIDNT=IMSA         ,SYSIDNT=IMSA         ,NETNAMEQ=DTP1</pre>
<pre>DEFINE SESSIONS(csdname) : :</pre>	<pre>DFHTCT TYPE=TERMINAL : :</pre>
<b>IMS-Initiated Asynchronous Processing</b>	
<pre>DEFINE CONNECTION(IMSC)     ACCESSMETHOD(VTAM)     NETNAME(SYSIMS)</pre>	<pre>DFHTCT TYPE=SYSTEM         ,ACCMETH=VTAM         ,SYSIDNT=IMSC         ,NETNAME=SYSIMS</pre>
<pre>DEFINE SESSIONS(csdname)     PROTOCOL(LU61)     SESSNAME(IMS1)     CONNECTION(IMSC)     NETNAMEQ(IST1)</pre>	<pre>DFHTCT TYPE=TERMINAL         ,TRMTYPE=LUTYPE6         ,TRMIDNT=IMS1         ,SYSIDNT=IMSC         ,NETNAMEQ=IST1</pre>
<pre>DEFINE SESSIONS(csdname) : :</pre>	<pre>DFHTCT TYPE=TERMINAL : :</pre>

**Recommendation:** Define up to three links (that is, groups of sessions) between a CICS and an IMS system, depending upon the application requirements of your installation:

1. A group of sessions for CICS-initiated distributed transaction processing (synchronous processing).

CICS applications that use the SEND/RECEIVE interface can use the SYSIDNT of this group to allocate a session to the remote system. The session is held (“busy”) until the conversation is terminated.

2. A group of sessions for CICS-initiated asynchronous processing.

## Defining Multiple Links to an IMS System

CICS applications that use the START command can name the SYSIDNT of this group. CICS uses the first “nonbusy” session to ship the start request.

IMS sends a positive response to CICS as soon as it has queued the start request, so that the session is in use for a relatively short period. Consequently, the first session in the group shows the heaviest usage, and the frequency of usage decreases towards the last session in the group.

### 3. A group of sessions for IMS-initiated asynchronous processing.

This group is also useful as part of the solution to a performance problem that can arise with CICS-initiated asynchronous processing. An IMS transaction that is initiated as a result of a START command shipped on a particular session uses the same session to ship its “reply” START command to CICS. For the reasons given in (2), the CICS START command is probably shipped on the busiest session, and, because CICS is the contention winner, the replies from IMS can create a backlog while waiting for a chance to use the session.

However, facilities exist in IMS for a transaction to alter its default output session, and a switch to a session in this third group can reduce backlog problems.

---

## Defining CICS Transactions for IMS-CICS ISC

This topic describes the unique considerations for transactions that participate in IMS-CICS ISC.

**Related Reading:** For complete details on the definition of CICS transactions, see the *CICS Resource Definition Guide*.

The following topics provide additional information:

- “Defining CICS Backout In-Doubt Processing”
- “Defining CICS Transactions for Asynchronous Communication to IMS”
- “Initiating and Allocating a Session from CICS” on page 555
- “Other Ways of Initiating a Session” on page 555
- “Terminating a Session from CICS” on page 556
- “Designing CICS Applications for ISC” on page 556

## Defining CICS Backout In-Doubt Processing

During the period between the sending of the syncpoint request to IMS and the receipt of the positive response, CICS does not know whether the remote system has committed. This period is known as the indoubt period. CICS processing during the indoubt period is controlled by the DEFINE TRANSACTION IN-DOUBT parameter (or the DFHPCT DTB= parameter).

DEFINE TRANSACTION IN-DOUBT (WAIT) or DTB=(YES,WAIT) must be specified in order to ensure consistency between the IMS and CICS subsystems within an ISC network.

## Defining CICS Transactions for Asynchronous Communication to IMS

A DEFINE TRANSACTION REMOTENAME (or DFHPCT TYPE=REMOTE RMTNAME) is needed for every IMS edit name or MID name that is to be referenced by a transaction created as the result of a CICS START command. The 4-character CICS transaction ID used on the START command is converted to the name of the IMS editor or to an MFS MID name, each of which can be up to 8 characters.



## Initiating and Allocating a Session from CICS

CICS can initiate a session in one of the following ways:

- The session can be initiated explicitly by use of AUTOCONNECT YES on the DEFINE CONNECTION (or CONNECT=AUTO on the DFHTCT TYPE=TERMINAL) macro. When CICS is initiated, it attempts to establish all sessions for which AUTOCONNECT is specified. In order for session initiation to occur, IMS must be active when CICS is initiated.
- The master terminal operator can initiate a session by entering the command:  
CEMT SET TERMINAL(*tttt*) ACQUIRED|COLDACQ

where *tttt* is the SESSNAME on the DEFINE SESSIONS or the TRMIDNT on the DFHTCT TYPE=TERMINAL.

If ACQUIRED is specified, normal resynchronization with the IMS is attempted.

If COLDACQ is specified, no resynchronization is performed.

The status of the CICS half session is typed over in the display area of the CEMT INQUIRE|SET TERMINAL command. If the session is initiated successfully, the status is changed from REL to ACQ. If the attempt to initiate the session is unsuccessful, an error message is written to the transient data destination CSMT.

- A session can be initiated implicitly by an application program using the ALLOCATE command. The ALLOCATE command is used on the SEND/RECEIVE interface only.

**Recommendation:** Use the ALLOCATE SYSID form of this command, because it allows CICS to select an available session.

If a session is not immediately available, control is returned to the application program in the following situations:

- A HANDLE CONDITION for this condition is issued by the application program.
- NOQUEUE is specified on the ALLOCATE command.

Otherwise, the command is queued.

The following conditions cause a session to be “not immediately available”:

- All sessions to the specified system (or the specified session) are in use.
- The only available sessions are not bound.
- The only available sessions are contention losers.

- A session can be initiated by CICS automatic task initiation (ATI).

The bind parameters for CICS are built from a hard-coded model. The RECEIVESIZE and SENDSIZE parameters on the DEFINE CONNECTION/SESSION (or the RUSIZE and BUFFER parameters on the DFHTCT TYPE=TERMINAL/SYSTEM) are used to determine the primary and secondary RU sizes.

**Related Reading:** For more information on the ALLOCATE command, and subsequent processing, see *CICS Intercommunication Guide*.

## Other Ways of Initiating a Session

Sessions not initiated by CICS can be initiated in one of the following ways:

- By IMS
- By the VTAM operator, NCCF, or Tivoli NetView for z/OS

### Terminating a Session from CICS

Sessions can be terminated by CICS only by using master terminal operator commands. The master terminal operator can use the CEMT command to release the session by entering:

```
CEMT SET TERMINAL(tttt) [RELEASED|OUTSERVICE]
```

In the example, *tttt* is the SESSNAME on the DEFINE SESSIONS or the TRMIDNT on the DFHTCT TYPE=TERMINAL.

If the master terminal operator specifies RELEASED, the session terminates when any active transaction completes and the session is in a between-brackets state.

If the master terminal operator specifies OUTSERVICE, the session also terminates when any active transactions complete and the session is in a between-brackets state. However, in this case, the session is taken out of service and cannot be used until the master terminal operator places it back into service.

If RELEASED is specified, it initiates an orderly termination between IMS and CICS. Although, from the CICS view, the session might appear to be in warm-start state, it is actually in cold-start state as a result of the SBI/BIS flow.

**Related Reading:** For more information on session states resulting from these shutdown protocols, see “Symmetrical Session Shutdown for LU 6.1 (SBI and BIS)” on page 355.

If OUTSERVICE is specified, the session is left in a warm-start state; that is, CICS requests resynchronization upon reinitiation. In order to initiate a session in cold-start mode, the CICS master terminal operator must specify:

```
CEMT SET TERMINAL (tttt) COLDACQ.
```

You can specify RELEASED and OUTSERVICE together.

**Related Reading:** For more information on initiating a session, see “Initiating and Allocating a Session from CICS” on page 555.

**Recommendation:** Although orderly session termination can occur as a result of the CICS application program issuing EXEC CICS DISCONNECT, this approach is not recommended in a normal application. However, an operator-control type of application can be written to use this function.

Any messages relative to the session’s termination are sent to transient data destination CSMT.

### Designing CICS Applications for ISC

CICS differs from IMS in that many of the flows that must occur on an ISC session occur under the control of the CICS application program. The CICS application must do the following:

- Build outbound ATTACH function management headers
- Supply fields for SCHEDULER function management headers (if required)
- Examine inbound ATTACH function management headers and process their contents
- Issue sync points at appropriate intervals during the application program’s processing.

The SNA bracket, SEND/RECEIVE, and sync-point protocols associated with CICS-generated messages depend upon the EXEC commands<sup>37</sup> used by the application program, and when the sync points are issued during the application flow.

Information is inserted into the ATTACH and SCHEDULER function management header DPN, RDPN, PRN, and RPRN fields for message editing and routing by IMS system code, and can be overridden only by using the IMS Message Format Service (MFS). For CICS, insertion of information into the ATTACH and SCHEDULER function management headers is performed under the control of the CICS application.

---

### Application-Related Concepts

This topic describes some application-related concepts to establish a common frame of reference for both CICS and IMS users.

The following topics provide additional information:

- “Subsystem Design—Direct-Control versus Queued”
- “Synchronous and Asynchronous Processing”
- “Principal and Alternate Facility” on page 559
- “CICS versus IMS Conversation Mode” on page 560
- “Sending IMS Commands from CICS” on page 561
- “Sync Points” on page 562

### Subsystem Design—Direct-Control versus Queued

CICS is a direct-control subsystem, while IMS is a queued subsystem. That is, CICS accepts data entered from a terminal, and as a result, invokes the appropriate application program to process that data. The terminal and other system resources are owned by the invoked application until the application task completes its processing. Information that results from processing is held in main storage rather than being queued. The implication for ISC is that the CICS application program is directly involved in generating the appropriate SNA data flow control, sync point, and response protocols, and in controlling most system services.

In contrast, IMS is a queued subsystem. In this case, all input and output transactions and message switches are queued by the IMS control region on behalf of the related IMS applications and terminals. Thus, the input and output of a message to or from the terminal are asynchronous from the processing of the message.<sup>38</sup> The implication for ISC is that the SNA protocols and many system services are handled under the control of IMS system code; the application program does not need to provide them.

### Synchronous and Asynchronous Processing

Message transmission can be synchronous or asynchronous between the terminal entering the message and the receiving subsystem. Messages can also be either synchronous or asynchronous with respect to the ISC session.

---

37. The EXEC commands are SEND/RECEIVE (for synchronous) and START/RETRIEVE (for asynchronous).

38. However, the processing might appear to be synchronous to the terminal because of the way in which the message is defined to IMS; for example, a response-mode message or a conversation might appear to be synchronous.

## Understanding Application-Related Concepts

**Related Reading:** For more information on ISC message transmission, see “Relationship of ISC and IMS Execution Modes” on page 272.

From the point of view of the CICS application, using the CICS SEND/RECEIVE EXEC commands produces synchronous processing on the session, while the CICS START/RETRIEVE EXEC commands result in asynchronous processing. When CICS is the front-end subsystem, both processing types are supported. When IMS is the front-end subsystem, only asynchronous processing can occur, unless the special support for front-end/back-end system utilization provided by IMS Front-End Switch exit routine is used.

**Related Reading:** For more information on the Front-End Switch exit routine (DFSFEJ0), see *IMS Version 9: Customization Guide*.

Table 85 shows how the CICS START/RETRIEVE and SEND/RECEIVE EXEC commands are supported from a CICS point of view.

*Table 85. The SEND/RECEIVE and START/RETRIEVE Commands*

Message Type	CICS to IMS	IMS to CICS
SEND/RECEIVE (synchronous)	YES	YES
START/RETRIEVE (asynchronous)	YES	YES

Table 86 shows the differences in the CICS application program interface when using SEND/RECEIVE or START/RETRIEVE.

*Table 86. CICS API for SEND/RECEIVE and START/RETRIEVE*

Attribute	SEND/RECEIVE	START/RETRIEVE
Mode	Synchronous with (SEND INVITE) or without (SEND LAST) reply	Asynchronous
FMH	ATTACH	ATTACH SCHEDULER
Name length	Supports 8-byte names	Supports 4-byte names <sup>1</sup>
Change Direction (CD)	Supported	CICS front-end cannot send CD. IMS sends CD to CICS if COMPT=SINGLE2 or MULT2.
Multiple chains per message (IUTYPE)	Supported <sup>2</sup>	Not supported
IMS component selection (DATASTREAM)	Supported	Not supported for input. Input component=1. Output component=any.
RECORDFORMAT: <sup>3</sup> Undefined (U)	Supported <sup>4</sup>	Not supported
RECORDFORMAT: <sup>3</sup> RU	Supported <sup>4</sup>	Not supported
RECORDFORMAT: <sup>3</sup> VLVB	Supported	Supported
RECORDFORMAT: <sup>3</sup> CHAIN <sup>5</sup>	Supported	Supported
FMH built by	Application program (BUILD ATTACH)	System: DPN, PRN, RDPN, RPRN specified in EXEC START command <sup>6</sup>

Table 86. CICS API for SEND/RECEIVE and START/RECEIVE (continued)

Attribute	SEND/RECEIVE	START/RETRIEVE
Access to FMH	Yes (EXTRACT Attach)	Any supplied parameters available on EXEC RETRIEVE command <sup>6</sup>
Relation to ISC session	Directly related (ALLOCATED)	Independent
IMS transaction types supported	Response mode Conversation mode Message switches <sup>7</sup> Commands Nonresponse, nonconversational <sup>7</sup>	Nonresponse mode Nonconversation Message switches Commands <sup>8</sup>
Recoverable I/O	Supported	Supported
Nonrecoverable I/O	Supported	Supported
Multisegment input	Supported	Single segment only
Multisegment output	Supported	Single segment only
IMS edits	Basic edit	Basic edit
Available	ISC Edit	ISC Edit
MFS: Without paging	Supported	Supported
MFS: Autopaged input: Single chain	Supported	Supported
MFS: Autopaged input: Single chain: Multichain	Supported	Not supported
MFS: Autopaged output	Supported	Not supported
MFS: Demand-paged output	Supported	Not recommended

**Notes:**

1. Names can be embedded in the message text. The DPN field can be converted from a 4-character to an 8-character name by using DEFINE TRANSACTION REMOTENAME (or DFHPCT TYPE=REMOTE).
2. Only used to send or receive MFS autopaged input or output messages.
3. The ATTACH parameters are defined in the CONNECTION definition. However, the application using START/RETRIEVE must understand and provide the correct data format within the application.
4. Marked as reserved by CICS, but can be specified on the BUILD ATTACH. For more information on the ATTACH parameters, see "ATTACH FM Header Format" on page 373.
5. Chained output from IMS requires the use of MFS.
6. The RDPN and RPRN are limited to 4-character names.
7. Nonresponse, nonconversational, and message switch input use SEND LAST only. CICS acquires replies to nonresponse and nonconversational transactions using RECEIVE.
8. /DIS, /RDIS, /FOR only.

## Principal and Alternate Facility

The functions of CICS synchronous EXEC terminal control commands (such as SEND, RECEIVE, CONVERSE) are exercised against a principal or an alternate facility. In CICS, the principal facility for a task is the terminal or ISC session that is made available to the application program when the task is initiated. The alternate facility is the ISC session that is allocated as needed by the application program.

## Understanding Application-Related Concepts

Commands issued against the principal facility are issued without the use of the SESSION (name) option. Commands issued against the alternate facility are issued with this option.

When CICS is the front-end subsystem, the user terminal is the principal facility. The session allocated to IMS is the alternate facility. However, when a restart transaction is attached from the ISC session, the session is the principal facility. The restart transaction does not have direct access to the user terminal.

**Related Reading:** For more information on restart and recovery processing within CICS, see “Recovery and Restart Concepts” on page 570.

### CICS versus IMS Conversation Mode

In IMS, conversation mode is an attribute of a transaction in which the conversation is carried on through the transfer of a scratch pad area (SPA) and an associated message between the terminal and transaction message queues. Each transfer of information to the transaction message queue and back to the terminal queue results in a sync point, and causes the commitment of resources and the release of locked resources. Also, all of the steps of an IMS conversation must occur entirely within a bracket. EB cannot be sent at any intermediate point in the conversation, because the receipt of EB causes IMS to discard the output message, terminate the conversation, and invoke the conversational abnormal termination exit. During a conversation, if a primary resource name (PRN) parameter is supplied in the input function management header, it is ignored, because the transaction code is carried in the SPA.

In CICS, a conversation is a series of interactions within a bracket between a terminal and an application. End-bracket occurs upon termination of the application. CICS also permits a “pseudo-conversation,” which is a sequence of transactions between a terminal and an application. Each transaction has one terminal input and one terminal reply within its own bracket. Either of these types of conversations can interact with IMS on the ISC session between the requests and replies by using the EXEC CONVERSE command. A message with end-bracket being sent to the terminal by CICS also causes an end-bracket message to be returned on the ISC session to IMS, if IMS has not previously sent an end-bracket status on the reply.

The differences in the way in which conversations are defined in CICS and IMS have the following implications for ISC:

- A terminal connected to CICS can only be held synchronously with the ISC session and IMS transaction processing if the CICS transaction is conversational in the CICS sense.
- If more than one input and output is to occur on the ISC session within a single bracket, the CICS transaction can interact with an IMS transaction that is defined as conversational. However, in the event of a session failure, the conversation might not be restartable.
- If only one input and output is to occur on the ISC session within a single bracket, the CICS transaction can interact with an IMS transaction defined as response mode. A series of transactions that make up a CICS pseudo-conversation can interact on an ISC session with a series of IMS transactions defined as response mode.

**Related Reading:** For more information on restart processing, see “Recovery and Restart Concepts” on page 570.

IMS conversational mode requires that IMS terminate the conversation by sending the last reply with RQD2,EB. Intermediate conversational messages are sent RQE2,CD. The CICS application can decide to terminate the conversation normally by issuing SYNCPOINT or RETURN. CICS can then terminate the conversation by sending LUSTATUS RQD2,EB in response to the last conversational output from IMS. In this case, the LUSTATUS acts as the acknowledgment for the RQE2,CD sent by IMS and closes that logical unit of work. The RQD2,EB causes IMS to respond with DR2 to close the bracket, dequeue the output message, and notify the Conversational Abnormal Termination exit routine that the conversation has been terminated normally by the remote program.

### Sending IMS Commands from CICS

IMS commands can be entered from any terminal authorized to use them. For terminals that are defined statically, this authorization is validated using the Security Maintenance utility (SMU) or Resource Access Control Facility (RACF) (or an equivalent product).

For terminals that are defined dynamically using ETO, this authorization is validated using RACF.

However, permitting a CICS application to issue IMS commands through the ISC session introduces IMS dependencies into the CICS application program. The consequences of this decision should be weighed before this facility is used.

A CICS application program can issue IMS commands by using the SEND/RECEIVE application program interface.

**Exception:** A CICS application program cannot issue the IMS commands /DISPLAY, /RDISPLAY, /FORMAT, and /TEST.

The IMS command verb is embedded in the message. It cannot be specified in the PROCESS parameter of the BUILD ATTACH command.

/DISPLAY, /RDISPLAY, and /FORMAT can be sent using START/RETRIEVE or SEND/RECEIVE. These commands differ from other IMS commands in that replies to these commands are queued by IMS rather than being immediately processed.

If these commands are issued with SEND (without LAST), IMS returns an LUSTATUS NO-OP as the reply to force end-bracket. IMS replies to these commands by sending the reply ATTACH BB/EB. CICS must use RECEIVE to obtain the reply. If a command is issued with SEND LAST, the reply message, when it is returned, is processed by a CICS transaction whose name has been previously specified in the RPROCESS field of the BUILD ATTACH.

If a command is issued using START/RETRIEVE, the reply is returned with both the ATTACH and SCHEDULER FM headers.

You can use the /TEST command for testing communication protocols and editing facilities on an ISC session when IMS is a back end to a CICS front end. Test mode requires the SEND/RECEIVE application program interface to be used.

#### **Related Reading:**

- For more information on using IMS commands with ISC, see “Issuing IMS Commands from an ISC Session” on page 270.

## Understanding Application-Related Concepts

- For information on the functions of test mode, see “Using IMS Test Mode for ISC Sessions” on page 271.
- For more information on RACF, see *IMS Version 9: Administration Guide: System*.
- For more information on using SMU, see *IMS Version 9: Utilities Reference: System*.
- For more information on the ETO feature, see *IMS Version 9: Administration Guide: Transaction Manager*.
- For more information on IMS commands, see *IMS Version 9: Command Reference*.

### Sync Points

ISC session protocols define RQ\*2 requests and their associated responses (DR2 or exception DR2) as sync point requests and responses. These requests and responses are functionally independent from RQ\*1 requests and their associated responses (DR1 and exception DR1), because these latter requests and responses do not cause a sync point. The sync-point responses (DR2) are used between ISC session partners to ensure that both partners' subsystem sync point managers can commit or back out recoverable resources in synchronism.

All messages sent or received on an ISC session are defined as either recoverable or nonrecoverable, depending on the message type. The session response protocols are used to ensure that both partners of an ISC session mutually understand and agree with the recoverability attributes associated with each message. The response protocols used must be consistent with the message type and are enforced by the sending and receiving subsystem sync point managers.

When one session partner commits a message, the other session partner is notified by positive session sync-point responses. When a session partner backs out a message as the result of errors detected during input or output processing, the other session partner is notified either by session termination, by an exception response sent by the receiving subsystem, or by an LUSTATUS-function abort sense code sent by the sending subsystem. Backout results in discarding the currently active message and resetting of the associated ISC data flow control (DFC) and ATTACH states to those of the last sync point.

Because CICS is a direct-control subsystem, synchronous transactions directly control the ISC session. Therefore, backout during synchronous transaction processing also results in backing out application updates made since the last sync point.

Queued subsystems and asynchronous application output do not provide direct control of the ISC session to the transaction; therefore commit or backout does not affect application updates that are made asynchronously to the message on the ISC session. Because IMS is a queued subsystem, session sync points are separate from application sync points, and always occur outside control of the executing application.

**Related Reading:** For information on the relationship of session sync points, see “Keeping Half Sessions Synchronized” on page 321.

### Sync Points on IMS Input

For any type of input, IMS does not schedule the intended transaction until the complete input message is successfully received. Processing errors and session failure prior to the receipt of the complete input message cause the entire message to be discarded or backed out and have no effect on other recoverable IMS resources, such as databases. However, the input message cannot be cancelled by



ISC session failures or protocols after the complete message is received, enqueued, and made available for scheduling. Only the current input message is backed out, even when several consecutive input (nonrecoverable) messages are received and enqueued because of a previous input sync point was requested. The definition and relationship of ISC input sync points to the application sync points depend upon whether the internal IMS execution mode for the input is synchronous or asynchronous.

**Related Reading:** For more information on ISC and IMS execution modes, see “Relationship of ISC and IMS Execution Modes” on page 272.

Synchronous transactions from CICS are sent using SEND/RECEIVE, which generates ATTACH with CD. The following IMS transaction types are synchronous:

- Response mode transaction
- Conversational mode transaction
- IMS commands
- Test mode input

Asynchronous transactions from CICS are sent using SEND LAST, which generates ATTACH with EB, or START/RETRIEVE, which generates ATTACH SCHEDULER with EB. The following transaction types are asynchronous:

- Nonresponse mode transaction
- Nonconversational mode transaction
- IMS message switch

For IMS, the sync-point response returned to CICS can indicate successful receipt of the message or can indicate the results of IMS processing. For asynchronous input to IMS, the sync-point response returned to CICS indicates only that the input message has been successfully enqueued and that the responsibility for message recovery is assumed by IMS. For synchronous input to IMS, the sync-point response returned to CICS indicates that the transaction has executed successfully and a sync point has been taken, even though transaction execution is independent of the session. IMS reflects this by returning the input sync-point response only after the application-inserted reply message is made available for output as the result of a successful application sync point.

**Related Reading:** For more information on this processing, see “Logical Unit of Work” on page 570.

### Sync Points on IMS Output

For output, IMS commits the output message when the requested sync-point response is returned by CICS. This means that the message has been successfully sent and dequeued and the session sync point information has been updated as appropriate. IMS backs out (depending upon the sense code used) the output message when an exception response is returned by CICS. In this case, the message is returned to the message queue for retransmission, and the associated DFC and Attach states are reset to those of the last ISC sync point. Backout on the ISC session does not affect the IMS application program or other recoverable resources, such as database updates. Backout of IMS conversational-mode output, in most cases, causes termination of the IMS conversation and the Conversational Abnormal Termination exit routine to be invoked. Based on the contents of the conversational SPA, user-provided exit logic might schedule another IMS transaction to back out database changes.

## Understanding Application-Related Concepts

### CICS Sync Points

For CICS, sync points occur under the control of the application program and can be issued at any time. For synchronous processing, when a sync-point request is issued by the application program, CICS logs the completion of the logical unit of work (that is, the resources are committed). In addition, when the SYNCPOINT command is issued within a CICS application, CICS is responsible for appending the ISC message that was created as a result of previous processing to the SNA response request (RQD1 or RQD2) that IMS expects. However, when a CICS asynchronous transaction is scheduled as a result of IMS input, the mirror transaction has already issued a sync point, that causes the appropriate response to be returned to IMS. Any sync points issued subsequently by the application have no effect on the ISC session.

---

## Coding Function Management Headers for CICS

“Function Management Headers” on page 356 describes the content and format of the SNA-defined function management headers used by IMS. The fields used by IMS are described in detail there. This topic describes how CICS uses some of the same function management header fields.

Unlike IMS, the CICS application program must prepare these function management headers and send them to IMS. CICS, itself, does not send them.

Both ends of an ISC session have an “attach manager” that performs the functions requested in the FMH.

## ATTACH Function Management Header

This topic describes the ATTACH function management header fields. The primary fields that CICS uses are ATTDPN, ATTPRN, ATTRDPN, and ATTRPRN.

### ATTDPN

The CICS transaction specifies the outbound destination process name field (ATTDPN) in the PROCESS field of the BUILD ATTACH command. This field, when sent by CICS to IMS, contains the name of an IMS editor (basic edit or ISC edit) or an MFS MID name that is to receive the inbound message. When received by CICS in a reply from IMS, this field contains the value that CICS sent to IMS as the return destination process name field (ATTRDPN) on the originating outbound message. If this is a reply to a nonresponse or nonconversational message sent to IMS with SEND LAST, this field identifies the transaction to be initiated to process this reply. In other cases, this value can be a CICS transaction code that identifies a restart transaction. If this value is not available, CICS uses the first four characters of the incoming data stream as the transaction code. If the reply is returned on the same session as that of the incoming message, IMS system code automatically wraps the incoming RDPN field into the DPN field of the reply message.

CICS ignores the ATTDPN if it is received in a reply returned from IMS.

**Exception:** After a session restart or a reply to a message sent with SEND LAST, ATTDPN is used to attach a CICS transaction.

When used with the SCHEDULER, the ATTDPN contains the DPN of the SCHEDULER model. In this case, the remaining ATTACH parameters are not sent by IMS, but rather, the information is supplied on the associated SCHEDULER model parameters.

**Related Reading:** For information on the SCHEDULER model parameters, see “SCHEDULER Function Management Header” on page 567.

### **ATTPRN**

The CICS transaction specifies the primary resource name field (ATTPRN) in the RESOURCE field of the BUILD ATTACH command. This field, when sent by CICS to IMS, names an IMS LTERM or transaction code that is the message destination. When this parameter is omitted, IMS uses the first eight characters of the data stream to identify the message destination.

**Recommendation:** To maintain consistency between IMS and CICS, use this field to name an LTERM for IMS message switches and place transaction codes in the first eight characters of the data stream.

When received by CICS in a reply from IMS, this field contains the value that CICS sent to IMS as the return primary resource name (ATTRPRN) on the outbound message. CICS ignores the ATTPRN if it is received in a reply returned from IMS.

#### **Exceptions:**

- After session restart, ATTPRN is used to determine the identity of the terminal that originated this transaction and must be acquired during the restart.
- When the reply is to a nonresponse or nonconversational transaction issued by CICS with SEND LAST, ATTPRN is used.

If the reply is to be returned on the same session as that of the incoming message, IMS automatically wraps the value received on the incoming RPRN field into the PRN field. MFS can be used to set or override this value on IMS output.

### **ATTRDPN**

The CICS transaction specifies the return destination process name (ATTRDPN) in the RPROCESS field of the BUILD ATTACH command. When CICS sends this field to IMS, it contains the code of a transaction to be executed in the event that a session restart is required or a reply is to be returned to a message that CICS sent to IMS using SEND LAST. IMS sends this to CICS when a next MID is specified within an MFS message output descriptor (MOD). When CICS receives the ATTRDPN field on an input message, it can be examined by the EXTRACT ATTACH command. This value should be saved and returned to IMS as the DPN on subsequent replies.

### **ATTRPRN**

The CICS transaction can place the identification of the originating terminal in this field. This identification is wrapped into the PRN field by IMS if a session restart is required or a reply is required to a message sent to IMS by CICS with SEND LAST. The CICS transaction places this value in the field by using the RRESOURCE field of the BUILD ATTACH and examines this field by using the EXTRACT ATTACH command.

For asynchronous unsolicited output, IMS uses the source LTERM name as the default, if a reply is necessary. MFS can be used to set or override this value on any type of output. When a CICS application receives this value, the value should be saved and returned as the PRN field for subsequent replies.

### **ATTDQN and ATTDQ**

When sent to CICS from IMS, on the ATTACH for a demand-paged output message, ATTDQN contains a unique message identifier. This field is only used for IMS demand paging. The CICS transaction specifies the destination message ID (ATTDQN) for subsequent demand-paged requests as the QNAME value in the

## Coding Function Management Headers for CICS

returned QMODEL FM header. When CICS receives ATTDQN from IMS, the ATTDQ field is set to 1. These fields are not set by IMS on any other conditions nor are they accepted by IMS on input.

### ATTIU

The CICS transaction specifies the interchange unit code (ATTIU) in the IUTYPE field of the BUILD ATTACH command. Two values can be specified: single chain, which applies to all non-MFS input or output, and multichain, which applies only to MFS-autopaged input and output. Single chain should be used unless the input to IMS is multiple-page MFS-autopaged input.

### ATTDSP

The CICS transaction specifies the data stream profile (ATTDSP) in the DATASTR field of the BUILD ATTACH command to determine the IMS component. This field can contain the following values:

X'00'	Identifies IMS component 1
X'01'	Identifies IMS component 2
X'02'	Identifies IMS component 3
X'03'	Identifies IMS component 4

When received by IMS, this input component determines the default output component, the input security requirements, and whether MFS can be used for input. The output component determines whether MFS is used for output, and the protocols that are to be sent on asynchronous output are sent ATTACH SCHEDULER. On output, IMS sets this value to the value of the output LTERM.

### ATTDBA

The CICS transaction specifies the deblocking algorithm (ATTDBA) in the RECFM field of the BUILD ATTACH command.

### ATTACC

This parameter is not supported on an ISC session and causes session termination if sent.

Table 87 summarizes the source of the values placed in the ATTACH FM header fields.

Table 87. Source of Values Placed in the ATTACH FM Header Fields

Major Field	A <sup>1</sup>	B <sup>2</sup>	C <sup>3</sup>
ATTDPN <sup>4</sup>	PROCESS	DPN	
ATTPRN	RESOURCE	PRN	
ATTRDPN	RPROCESS	RDPN	
ATTRPRN	RRESOURCE	RPRN	
ATTDQN	QUEUE	Message ID <sup>5</sup>	
ATTIU	IUTUPE <sup>6</sup>	Paging <sup>6</sup>	
ATTDSP	DATASTR <sup>7</sup>		COMPTn <sup>8</sup>
ATTDBA	RECFM <sup>7</sup>		VLVB
			DPM-Bn <sup>9</sup>

Table 87. Source of Values Placed in the ATTACH FM Header Fields (continued)

Major Field	A <sup>1</sup>	B <sup>2</sup>	C <sup>3</sup>
<b>Notes:</b>			
1. CICS EXEC BUILD/EXTRACT ATTACH.			
2. Set by IMS MFS; or, if MFS is not used, and the output is asynchronous unsolicited output, the RPRN defaults to the source LTERM name.			
3. IMS COMPTn in TERMINAL/NAME macros.			
4. For asynchronous processing, this field indicates “SCHEDULER follows” by containing the value X'02'. In this case, the remaining header fields are not contained in the ATTACH FM header, but are contained instead in the concatenated SCHEDULER FM header.			
5. Message ID for MFS demand paging.			
6. Value is set depending on MFS autepage.			
7. Second byte of these halfword binary fields is used.			
8. Components numbered 1 through 4.			
9. DPM-Bn permits MFS to be used. Using MFS MODE=STREAM on output changes the ATTDBA to chain mode; otherwise, IMS uses the default of VLVB.			

## SCHEDULER Function Management Header

The SCHEDULER function management header can be used to send asynchronous messages between IMS and CICS. On input, receipt of the SCHEDULER FMH causes CICS to invoke the mirror transaction to schedule the asynchronous transaction that is to process the input. On output, it is generated as a result of CICS using the START command with its associated fields as follows:

### SCDDPN

The CICS transaction specifies the value to be placed in the outbound destination process name field (SCDDPN) in the TRANSID field of the START command. This field, when sent by CICS to IMS, contains the name of an IMS editor (MFS, basic edit, or ISC edit) that is to receive the inbound message. If SYSID is not coded on the START command, this TRANSID can be modified (to contain an 8-character name, for example) as a result of the RMTNAME option in the program control table (PCT).

When received by CICS in a reply from IMS, this field contains the value that CICS sent to IMS as the return destination process name field (SCDRDPN) on the outbound message. IMS automatically wraps the incoming RDPN field into the DPN field of the reply message. Alternatively, this field might have been set by the IMS MFS. This value is a CICS transaction code. If this field is not supplied on input to CICS, CICS uses the first four characters of the input data stream as the transaction code.

### SCDPRN

The CICS transaction specifies the primary resource name field (SCDPRN) in the TERMID field of the START command. This field, when sent by CICS to IMS, names an IMS LTERM or transaction code that is the message destination. If this field is omitted when CICS sends a message to IMS, IMS examines the first eight bytes of the incoming message to extract the message destination.

**Recommendation:** To maintain consistency between IMS and CICS, use this field to name an LTERM for IMS message switches and place transaction codes in the first eight characters of the data stream.

## Coding Function Management Headers for CICS

When received by CICS in a reply from IMS, this field contains the value that CICS sent to IMS as the return primary resource name (SCDRPRN) on the outbound message or a value placed into the field by MFS. This field contains a value that identifies the terminal that is to be used as a principal facility and to which the reply should be sent.

### SCDRDPN

The CICS transaction specifies the return destination process name (SCDRDPN) in the RTRANSID field of the START command. When CICS sends this field to IMS, it contains the name of the asynchronous transaction to be scheduled by the CICS mirror transaction when the reply is received.

For unsolicited asynchronous output, the RDPN can be set by MFS to indicate the next message input descriptor (MID) to be used for subsequent replies. If this parameter is received as input by CICS, this parameter should be saved and returned to IMS in the TRANSID (DPN) of the START command.

### SCDRPRN

The CICS transaction specifies the return primary resource name (SCDRPRN) in the RTERMID field of the START command. When CICS sends SCDRPRN to IMS, it contains the identification of the terminal to which the return reply should be routed. On output from IMS to CICS, IMS sets SCDRPRN to the name of the source LTERM. MFS can also set SCDRPRN. The SCDRPRN value should be saved by CICS and returned to IMS as the TERMID (PRN) on any subsequent replies.

### SCDDQN and SCDDP

Because asynchronous demand paging is not recommended, these fields are not used in a CICS-IMS ISC session.

The SCHEDULER header is preceded by an ATTACH header. Some mandatory ATTACH FM header fields also apply to asynchronous messages. These fields are not carried on the SCHEDULER header, but are retained on the ATTACH header. These fields are the ATTIU, ATTDSP, and ATTDDBA fields.

**Related Reading:** For more information on these fields, see “ATTACH Function Management Header” on page 564. Their values in the asynchronous environment are as follows:

- ATTIU  
CICS only supports single-chain messages between itself and IMS.
- ATTDSP  
When sent using the START command, the ATTDSP value is determined by the terminal-control table generation, and should be X'00' (component 1). For input and output, the definition of the ATTDSP field for IMS is the same as that described in “ATTACH Function Management Header” on page 564.
- ATTDDBA  
The CICS transaction specifies the deblocking algorithm (ATTDDBA) in the RECFM field of the BUILD ATTACH command.

Table 88 summarizes the source of the values placed in the SCHEDULER FM header fields.

*Table 88. Source of Values Placed in the SCHEDULER FM Header Fields*

Major Field	A <sup>1</sup>	B <sup>2</sup>	C <sup>3</sup>	D <sup>4</sup>
SCDDPN	TRANSID <sup>5</sup>		DPN	

## Coding Function Management Headers for CICS

Table 88. Source of Values Placed in the SCHEDULER FM Header Fields (continued)

Major Field	A <sup>1</sup>	B <sup>2</sup>	C <sup>3</sup>	D <sup>4</sup>
SCDPRN	TERMID <sup>5</sup>		PRN	
SCDRDPN	RTRANSID <sup>5</sup>		RDPN	
SCDRPR	RTERMID <sup>5</sup>		RPRN	
SCDDQN	QUEUE		Note 6	
ATTIU <sup>7</sup>			Note 6	
ATTDSP <sup>7</sup>		DATASTR <sup>8</sup>		COMPTn <sup>8</sup>
ATTDBA <sup>7</sup>		RECFM		VLVB
				DPM-Bn <sup>9</sup>

**Notes:**

1. CICS EXEC START/RETRIEVE.
2. CICS DEFINE CONNECTION or DFHTCT TYPE=SYSTEM.
3. Set by IMS MFS; or, if MFS is not used, for output that is unsolicited asynchronous output, the RPRN defaults to the source LTERM name.
4. IMS COMPTn in TERMINAL/NAME macros or on an ETO logon descriptor.
5. Four-byte name; MFS supports an eight-byte name.
6. MFS paging is not recommended on an asynchronous session between IMS and CICS.
7. ATTACH FMH fields preceding SCHEDULER FMH.
8. DATASTR must be specified as USER. This causes X'00', specifying IMS component 1, to be indicated as the input component. The IMS output component can be components 1 through 4 (X'00'- X'03').
9. DPM-Bn permits MFS to be used. Using MFS MODE=STREAM on output changes the ATTDBA to chain mode; otherwise, IMS uses the default of VLVB.

## Queue Model Function Management Headers

CICS uses the QMODEL headers to access IMS MFS demand-paged messages. QMODEL headers are not sent by IMS to CICS. For SEND/RECEIVE, the CICS application program must prepare the QMODEL function management headers in order to receive demand-paged output from IMS. Temporary storage function shipping can be used with START/RETRIEVE. No EXEC commands exist to support the coding of QMODEL FM headers. The following QMODEL headers are used for MFS demand paging:

<b>QGET</b>	Requests a page directly
<b>QGETN</b>	Requests the next sequential page
<b>QPURGE</b>	Requests termination of demand paging
<b>QXFR</b>	Sent with the requested page
<b>QSTAT</b>	Sent when QPURGE is received, or when the requested page number is invalid

## Data Descriptor Function Management Header

IMS uses this header to specify a device page (DPAGE). It is not used by CICS, but can be passed to a CICS transaction. A CICS synchronous transaction can build and send data descriptor FM headers to IMS as appropriate. However, no EXEC commands exist to support the coding of data descriptor FM headers.

### System Message Process (SYSMSG) Function Management Header

IMS uses this header to send system messages. System messages are appended to an ATTACH carrying DPN=SYSMSG. CICS routes these messages to a synchronous application when the session is allocated to that transaction or to destination CSMT at any other time. If routed to a transaction, that transaction is responsible for processing the SYSMSG function management header. CICS does not send SYSMSG, but a synchronous application program can cause a SYSMSG to be sent by setting the appropriate process name in the BUILD ATTACH. The application program is responsible for building the appropriate SYSMSG FMH to be appended to the ATTACH.

SYSMSG is sent by IMS for broadcast messages or for the case in which a response to input has been sent, but has had a subsequent processing error. After a response to asynchronous input, SYSMSG is sent in lieu of the reply message. During synchronous processing, SYSMSG is sent:

- After a session restart, if the transaction in progress abends during the session outage
- During MFS output, if MFS output format blocks are not available or are not valid

### Error Recovery Procedure Function Management Header

CICS sends and receives this header, which is used to transmit error information from one process to another. The header is sent after an exception response (X'0846') and carries sense codes, which are used to inform the half-session partner of the nature of the error. It is followed by an error message. CICS writes the received IMS error message to the transient data destination CSMT; IMS writes the received CICS error message to the master terminal or the input source node.

---

## Recovery and Restart Concepts

This topic describes the system and user functions that must be performed to recover an ISC session after a session, system, or application failure. It assumes the reader understands the role of the STSN command in session resynchronization.

**Related Reading:** For the format of the STSN action and response commands, see “Determining Session Synchronism Using STSN” on page 310.

The concepts of sync point, commit, backout, and logical unit of work are common to IMS and CICS. However, their meanings differ slightly within IMS and CICS.

**Related Reading:** For information on sync points, see “Sync Points” on page 562.

### Logical Unit of Work

A logical unit of work is any processing that occurs between sync points. Within subsystems where the application directly controls the session, such as CICS, the application sync point and the ISC session sync point occur simultaneously as the result of a single explicit or implicit application command. Within queued subsystems, such as IMS, the application processing and sync points are independent of those of the ISC session. IMS must map the application sync point to the ISC session sync-point request.

In the synchronous case (SEND/RECEIVE), CICS is the front-end subsystem. One logical unit of work includes all of the processing performed in both the IMS and



CICS subsystems, from the point at which the CICS application last issued a sync point to the point at which the next sync point is issued, and a sync-point response is returned.

If the transaction is recoverable, only one message can be sent to IMS before the sync point must be requested by the CICS application. However, a series of nonrecoverable requests and replies can occur between a CICS sync-point request and an IMS response.

For recoverable messages, IMS returns this response only after the IMS application has inserted a response or conversational mode reply message and caused an application sync point. IMS then begins the next logical unit of work by sending the reply message requesting a sync point. The reply message satisfies the RECEIVE issued by the CICS transaction. The CICS transaction should complete all necessary processing prior to issuing a SYNCPOINT or RETURN (implicit sync point) command.

The application sync point causes CICS to return a sync-point response to IMS. IMS then completes the logical unit of work by dequeuing the reply message from the output message queue.

In the asynchronous case, where CICS is the front-end subsystem, for recoverable input to IMS, the input request and the returned reply message are separate logical units of work. When the CICS application issues a SEND LAST or START and requests a sync point, IMS returns the sync-point response as soon as the transaction is enqueued (made available for scheduling). IMS sends any recoverable asynchronous reply messages as they are made available by the transaction and requests a sync point on each. When the reply message is read by the CICS mirror transaction, an appropriate response is automatically returned to IMS. If the reply message is read using RECEIVE as a result of a previous SEND LAST, the sync point response is not returned to IMS until a subsequent SYNCPOINT, FREE, or RETURN command is issued.

One or more nonrecoverable transactions can be sent to IMS between CICS sync points using multiple START commands, each followed by a RETRIEVE. When the reply message is read by the CICS mirror transaction, an appropriate response is automatically returned to IMS.

The concept of logical unit of work (or work unit) is important in that session resynchronization must be performed when initiating a session and up to one work unit is considered to be indoubt on a flow from either the primary to the secondary half session or from the secondary to the primary. An indoubt work unit is one that is waiting to be committed or backed out based on the results of the session BIND and STSN flow.

### Recovering Outstanding Message Traffic after a Failure

A CICS-IMS session can fail or terminate in any of the following situations:

- A communication component (for example, VTAM or NCP) fails.
- The CICS or IMS subsystem fails.
- A direct VTAM or subsystem command (for example, an IMS /CLSDST or /STOP command) is entered.
- The CICS transaction or IMS transaction fails (indirectly as a result of subsequent error processing).

## Recovery and Restart Concepts

In each of these situations, the session failure appears similar to the remaining operative subsystems. However, the resulting recovery and resynchronization processes you must follow differ. This topic describes what happens in the event of a communication component failure, an IMS or CICS subsystem failure, or the issuing of a direct command against the session between the two subsystems.

**Related Reading:** For information on abnormal termination of an IMS or CICS transaction, see "Handling Transaction Abends" on page 575.

### Reestablishing the Session

The failed session can be restarted by either half-session partner. When it is restarted, the relationship of the half sessions is the same as when the session failed; that is, the former primary half session continues to be primary and the former secondary half session to be secondary. Both IMS and CICS remember this orientation by logging the session qualifier pair (SQP) used to initiate the session with an indicator of the session polarity.

The CICS master terminal operator can reinitiate the session using the command:  
CEMT SET TERMINAL (*tttt*) ACQUIRED

where *tttt* is the TERMIIDNT of the CICS session as defined in the terminal control table. CICS then brings up the session, maintaining the session polarity that has been fixed by CICS system definition parameters. If the session is being initiated by an authorized IMS terminal operator's issuing the /OPNDST command, that command must specify the same subpool name (IMS local session qualifier name) and session ID (CICS local session qualifier name) that was allocated to the session at the point of failure. These are available to the operator as necessary using an IMS /DISPLAY command. IMS automatically reestablishes the session, while maintaining the same session polarity as was in effect at session failure.

If the session is being restarted with IMS in cold-start mode, and if CICS is defined to be the primary half session, CICS must initiate the restart.

When the session is reestablished, IMS attempts to reset the data flow control bracket state to its status at the last sync point before session failure. CICS allows the session to be reestablished as between-brackets or as in-brackets with IMS in SEND state.

### Resynchronizing the Session

When a session is active, both IMS and CICS maintain a set of SNA message sequence numbers for that session. When a failure occurs and restart is attempted, the total of sync points on the session is checked between the subsystems by the STSN command.

**Related Reading:** For more information on STSN content and flow, see "Determining Session Synchronism Using STSN" on page 310.

The CICS/IMS session resumes if both of the following are true:

- The session is being cold-started.
- The half sessions' sequence numbers agree, or are within acceptable limits.

**Related Reading:** For more information on the acceptable range of session sequence numbers, see "Set-and-Test-Sequence-Numbers (STSN)" on page 466.

If a session fails, a CICS transaction having pending activity for that session also fails. CICS uses dynamic transaction backout (DTB) to ensure integrity of recoverable resources. The DTB indoubt parameter must be specified as IN-DOUBT(WAIT) or DTB=(YES, WAIT) in order to ensure consistency between the IMS and CICS subsystems within an ISC network.

**Related Reading:** For more information on CICS backout indoubt processing, see “Defining CICS Backout In-Doubt Processing” on page 554.

WAIT holds locks on recoverable resources until resynchronization occurs.

If this situation is undesirable, you can specify IN-DOUBT(BACKOUT) or DTB=YES on an IMS-CICS ISC transaction. However, doing so might cause duplicate messages to be sent to IMS after session resynchronization, and can require logic in the IMS user transaction to resolve them.

If the DTB indoubt parameter does not specify WAIT, you must specify FORCSESS on the IMS TERMINAL macro system definition OPTIONS parameter or use an authorized IMS terminal operator /CHANGE command.

### Processing Outstanding Traffic

In IMS, transaction processing is independent of session status; that is, if a message is received and successfully queued, it is always processed. However, the way in which IMS handles subsequent replies and continues processing conversations depends on the type of message, the type of error that occurs, and whether the IMS subsystem fails.

In general, when only the session fails (and IMS does not fail), and no synchronous processing is occurring between IMS and CICS, the following is true:

- The session is bound between-brackets when it is reinitiated.
- IMS always sends or resends asynchronous replies or unsolicited asynchronous output after successful session restart.
- IMS sends or resends queued asynchronous replies resulting from /DISPLAY, /RDISPLAY, and /FORMAT commands.
- If the IMS asynchronous transaction abends during the session outage, IMS sends an error message using ATTACH SYMSG, because exception responses are no longer possible.

For replies processed synchronously by IMS:

- If response mode or conversational output is pending, the session is bound with IMS in-brackets/SEND to permit the pending reply to be sent or re-sent.
- When in conversation mode and input is required, IMS attempts to bind in-brackets/RECEIVE. CICS negotiates this bind to a between-brackets state, causing IMS to terminate the conversation, discard the output message, and invoke the Conversational Abnormal Termination exit routine. This exit routine can invoke user processing to schedule an IMS transaction to back out any database changes resulting from previous conversational processing based on the contents of the SPA.

When a session is reestablished and sent to between-brackets as described in the preceding paragraph, if the IMS transaction has not yet completed processing the conversational or response mode input (that is, output is not yet available), IMS terminates the session with a message to the master terminal operator

## Recovery and Restart Concepts

requesting that the session be reinitiated (when output is available). This occurs because IMS cannot terminate the in-process transaction as required by the between-brackets bind.

- Except as mentioned, IMS cancels any commands received at the point of failure and discards pending synchronous reply messages that result from an IMS command.
- If the IMS synchronous transaction abends during the session outage, IMS sends an error message using ATTACH SYSMSG, because exception responses are no longer possible.

IMS handles these transactions in the following manner:

- After an emergency restart, IMS discards a pending reply message resulting from a nonrecoverable transaction.
- After IMS receives and enqueues an input transaction, session protocols or failures cannot cancel that transaction.
- After a reply message to a CICS synchronous transaction (response mode or conversation) is enqueued, it indicates that the results of all previous IMS processing have been committed. These updates are not backed out even if the reply message is discarded.

If a CICS transaction must be re-sent to IMS as determined by STSN processing, the CICS application, rather than the CICS subsystem itself, must make this determination and either reconstruct the transaction or request that it be reentered.

**Related Reading:** For more information on IMS transaction abends, see “IMS Transaction Abend” on page 575.

After a session fails, CICS cannot reestablish the environment in which the original transaction was executing. That is, the connection to the terminal that originally entered the transaction no longer exists. Further, the transaction has abnormally terminated; therefore, it is necessary for the CICS application programmer to define a “restart transaction” to be invoked by CICS to handle any IMS output that CICS might receive on the restarted session. When this transaction is invoked, the session, rather than the terminal, is now the primary facility. This transaction must in turn invoke an asynchronous transaction to acquire the terminal if output exists that needs to be sent to it.

The transaction code of the restart transaction to be invoked is carried in the DPN field of the function management header that is sent to CICS with the input message. This transaction code is the one specified in the RPROCESS field of the BUILD ATTACH command sent by CICS with the outbound message. This becomes the RDPN parameter automatically wrapped by IMS to the DPN field, which IMS sends on the outbound FMH unless modified by the IMS MFS.

The ID of the terminal to which CICS is to send any output reply is found in the PRN field of the incoming function management header. This is the value specified in the RRESOURCE field of the BUILD ATTACH sent by CICS with the outbound message. This becomes the RPRN parameter automatically wrapped by IMS to the PRN field of the outbound FMH unless modified by MFS. This value is used as the TERMID of the asynchronous transaction scheduled (START) by the restart transaction to acquire the terminal.

The restart transaction issues a RETRIEVE carrying both TRANSID and TERMID fields. When the transaction specified by the TRANSID is initiated, it owns the terminal specified by the TERMID as its principal facility.

**Related Reading:** For more information on designing CICS restart transactions, see “Coding CICS Applications for Restart” on page 576.

---

### Handling Transaction Abends

In addition to the considerations for session and subsystem failure, the design of CICS recovery transactions must also take into account the actions to be taken in the case of transaction termination as described in the topics that follow.

#### IMS Transaction Abend

When an IMS transaction terminates abnormally, all changes to IMS resources that were performed by this transaction are backed out by IMS. If the transaction is synchronous (CICS SEND/SYNCPOINT), IMS sends a negative response (exception DR2) to CICS. This causes the CICS transaction to also terminate abnormally. As a result of the negative response and subsequent CICS transaction abend, CICS backs out any changes made to recoverable resources after the previous CICS sync point. An error message is also sent to CICS; CICS routes this message to the master terminal destination CSMT. The exception occurs when MFS output formats do not exist in the format library or incur an I/O error. In this case, IMS has already sent a positive sync-point response and must indicate the MFS error to CICS by using an ATTACH SYMSG.

If the transaction is asynchronous (CICS START or SEND LAST), IMS sends an error message to CICS; CICS routes this message to its master terminal destination. The error message is preceded by either a SYMSG or an ERP header, depending upon the type of error that occurs. If the error occurs before IMS sends a sync-point response to input, an exception response and ERP are used; if after the sync-point response, ATTACH SYMSG is used.

**Related Reading:** For more information on function management headers, see “Coding Function Management Headers for CICS” on page 564.

#### CICS Transaction Abend

If a transaction is initiated by a CICS subsystem acting as a front end for IMS, and that CICS transaction terminates abnormally before reaching sync point, any processing performed is handled in accordance with the specification on the DEFINE TRANSACTION IN-DOUBT parameter (or DFHPCT DTB= parameter).

If an asynchronous transaction is initiated by an IMS front end and the CICS transaction abends upon receipt of the transaction, IMS is not notified. This is because the receipt of the message causes the CICS mirror transaction to return an immediate DR2 to the asynchronous input and to schedule a transaction to process it. If this scheduled transaction fails, the ISC link to IMS is no longer active and no notification is possible. CICS does, however, notify the CICS destination CSMT of the transaction failure.

During synchronous processing, if CICS is the secondary half session, the ALLOCATE command has been successfully issued, and no message is available to be sent to IMS (due, for example, to DTB causing backout), CICS automatically deallocates the session by sending LUSTATUS BB/EB to IMS.

If the synchronous transaction terminates abnormally any time after it has sent a message to IMS using the SEND/SYNCPOINT command, and that message has been enqueued on an IMS input queue, IMS processes it. When IMS attempts to send an output message to CICS, that message receives a negative response from CICS. As

## Handling Transaction Abends

a result, the message can remain on the IMS output queue until it can be re-sent or until it is dequeued by the IMS master terminal operator.

**Related Reading:** For information on the ERP sense code actions, see “Error Recovery Procedure Function Management Header” on page 570.

---

## Coding CICS Applications for Restart

When a failure occurs on an ISC session as a result of session or subsystem failure, session restart and resynchronization can be attempted. If session resynchronization (STSN processing) is unsuccessful and the session cannot be restarted without intervention, the master terminal operators of both subsystems are notified. This situation can require that the terminal user also be notified of the session’s status and of any actions that must be taken, such as reentering the failing transaction or waiting until corrective action is taken by the MTO.

After an ISC transaction defined as recoverable is received and logged by IMS, it can be recovered across session and subsystem failures. After restart, when the session has been recovered, if IMS has pending output, it is sent as follows:

- When IMS sends output on the same session as that on which the input message is received, that output message is sent with the same type of headers as those originally sent with the input. Thus, a reply to a message sent with SEND/RECEIVE or SEND LAST is returned with the ATTACH FM header and a reply to a message sent with START/RETRIEVE is returned with the ATTACH and SCHEDULER FM headers.
- When IMS sends output on a session other than that on which the input message is received, that output message is considered as unsolicited output and is sent asynchronously (with ATTACH SCHEDULER).

After a restart, when IMS sends an output message, CICS reads the input message and initiates a transaction.

- Within the application, the EXEC ASSIGN STARTCODE parameter is examined to determine whether this transaction had been initiated synchronously or asynchronously.
- If the restart transaction is initiated asynchronously:
  - A RETRIEVE is issued to obtain the ISC reply. The EIB indicators should be saved. CICS attaches the end-user’s terminal to this CICS program as the principal facility. This permits the IMS output to be issued directly to the terminal using a CICS EXEC SEND command.
  - The EIB indicators, saved after RETRIEVE execution, must be tested to determine whether SYNCPOINT or RETURN can be issued to end this transaction.
- If the transaction is initiated synchronously by SEND/RECEIVE or asynchronously by SEND LAST:
  - The input message is obtained using RECEIVE. In this case, the session is now the principal facility. Therefore, the RECEIVE command does not require specification of the SESSION parameter.
  - After the RECEIVE, the CICS application saves and then checks the EIB fields EIBSYNC, EIBFREE, and EIBRECV, in that order.
  - The application now issues an EXTRACT ATTACH to determine the format of the input data and the ID of the terminal that originally submitted the transaction.

- The restart logic must now START an additional CICS transaction to acquire the end user's terminal as the principal facility. The START request is made with the terminal ID found in the PRN field by using the EXTRACT ATTACH as the TERMID parameter on the START.
- The EIB indicators are now tested to determine whether a sync point is required and whether the session can be freed. If this can be done, the application can issue a RETURN command to implicitly cause a sync point to be issued and the session to be freed.

Within the context of the restart transaction, data can be retrieved for inquiry purposes or databases and files can be updated.

In addition to the foregoing logic, a CICS restart transaction can contain logic to:

- Store input received from the originating terminal on temporary storage. If it is necessary to re-create an input transaction, this information can be obtained and re-sent to IMS.
- Create logic to inform the terminal user of any special processing to be performed, such as reentering a transaction or waiting for some master terminal operator action before proceeding.





---

## Appendix H. ISC Data Flow Control Examples

This appendix provides ISC data flow control examples.

**In this Appendix:**

- “Non-MFS Bracket and Half-Duplex Protocol Examples”
- “MFS Bracket and Half-Duplex Protocol Examples” on page 581
- “SBI/BIS Examples” on page 585
- “Signal Protocol Example” on page 586

---

### Non-MFS Bracket and Half-Duplex Protocol Examples

These topics provide Non-MFS Bracket and Half-Duplex Protocol examples that illustrate ISC data flow control protocols:

- Figure 83: Example 1: Bracket Protocol for a PHS Component Defined to IMS as SINGLE1
- Figure 84 on page 580: Example 2: Bracket Protocol for a PHS Component Defined to IMS as SINGLE2
- Figure 85 on page 580: Example 3: Bracket Protocol for a PHS Component Defined to IMS as MULT1
- Figure 86 on page 580: Example 4: Bracket Protocol for a PHS Component Defined to IMS as MULT2

**Note:** The items in parentheses are optional on the flow.

For simplicity, the examples in this topic assume only-in-chain SCHEDULER messages for flows in both directions, and the response, ATTACH, and SCHEDULER protocols have been excluded. Also, the bracket protocol is considered symmetrical in that either the primary half session (PHS) or the secondary half session (SHS) can initiate the bracket as illustrated.

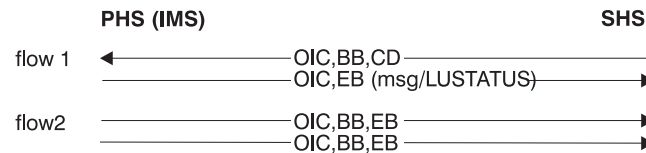

Figure 83. Example 1: Bracket Protocol for a PHS Component Defined to IMS as SINGLE1

Sample flow 1 shows the PHS ending a bracket on the first output following receipt of change-direction. When no output exists and the input cannot guarantee output, the bracket is ended through a stand-alone LUSTATUS.

Sample flow 2 shows the PHS sending output that occurs while in a between-brackets state.

## Non-MFS Bracket and Half-Duplex Protocol Examples

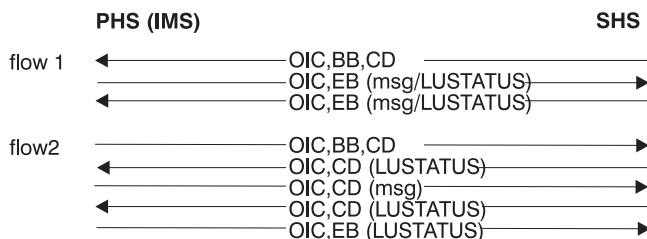

Figure 84. Example 2: Bracket Protocol for a PHS Component Defined to IMS as SINGLE2

Sample flow 1 shows the PHS returning the flow to a bracket initiator after receipt of a change-direction. The bracket initiator can optionally continue input or end the bracket. When no output exists and the input cannot guarantee output, the flow is returned to the bracket initiator using a stand-alone LUSTATUS.

Sample flow 2 shows the PHS sending asynchronous output. Also, IMS detects a potential LUSTATUS CD loop and forces end-bracket using LUSTATUS.

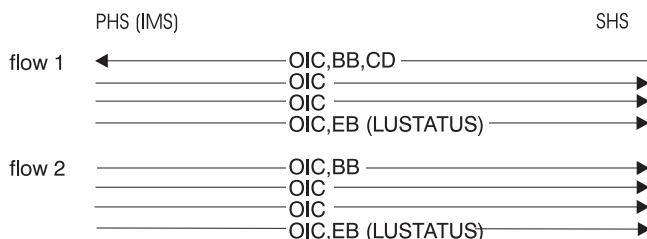

Figure 85. Example 3: Bracket Protocol for a PHS Component Defined to IMS as MULT1

Sample flow 1 shows the PHS ending a bracket using an LUSTATUS. The bracket ends following the last output from a queue after receipt of change-direction. If no output exists and the input cannot guarantee output, the bracket is ended immediately by using a stand-alone LUSTATUS.

Sample flow 2 shows the PHS both beginning and ending a bracket by using an LUSTATUS following the last output from a queue. Additional output available from other queues causes subsequent brackets to be initiated.

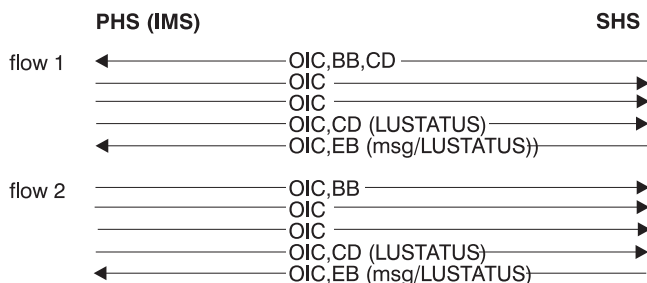

Figure 86. Example 4: Bracket Protocol for a PHS Component Defined to IMS as MULT2

Sample flow 1 shows the PHS returning the flow to the bracket initiator using an LUSTATUS. The bracket ends following the last output from a queue after receipt of a change-direction. The bracket initiator can optionally continue input or end the

bracket. If no output exists and the input cannot guarantee output (that is, the input is not in conversational or response mode), the flow is returned by using a stand-alone LUSTATUS.

Sample flow 2 shows the PHS sending output that occurs in a between-brackets state.

## MFS Bracket and Half-Duplex Protocol Examples

This topic provides examples for both MFS output and MFS input.

### MFS Output Examples

In examples 1 through 4, the IMS message consists of 3 presentation pages:

- Logical page 1 that makes up 2 presentation pages
- Logical page 2 that makes up 1 presentation page

In the examples shown in Figure 87, Figure 88 on page 582, Figure 89 on page 583, Figure 90 on page 583, and Figure 91 on page 583, the ATTACH FM header showing DPN=X'.03' is optional.

**Exception:**For the first paging request, the ATTACH FM header showing DPN=X'03' is required.

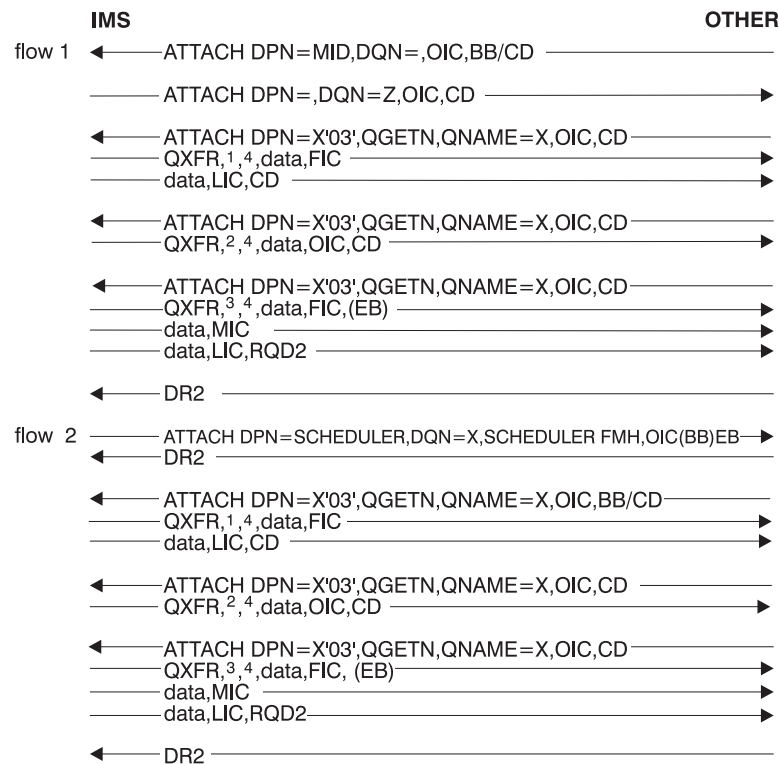

Figure 87. Example 1: Demand-Paged Output, Operator Logical Paging (OLP) Not Defined, Sequential Retrieval Using QGETN FM Header

IMS action: Remove message from the message queue

## MFS Bracket and Half-Duplex Protocol Examples

### Notes:

1. QCURSOR=0400010001, QCOUNT=020002
2. QCURSOR=0400010002, QCOUNT=020002
3. QCURSOR=0400020001, QCOUNT not present
4. DD FM header can precede the data

The QNAME returned on paging requests must be the same value as sent on the output ATTACH DQN.

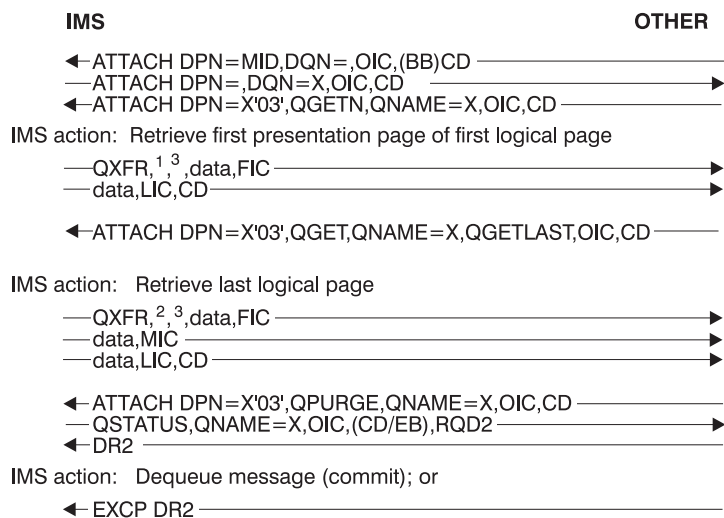

Figure 88. Example 2: Demand-Paged Output, OLP Defined, QGET (Last Page Request and by Cursor) Used. QPURGE Used To Dequeue the Message

### Notes:

1. QCURSOR=0400010001, QCOUNT=020002
2. CURSOR=0400020001, QCOUNT not present
3. Data descriptor FM header can precede the data

These same conditions for non-SCHEDULER demand-paged output result in an exception response and in subsequent ERP FMH7 being sent.

## MFS Bracket and Half-Duplex Protocol Examples

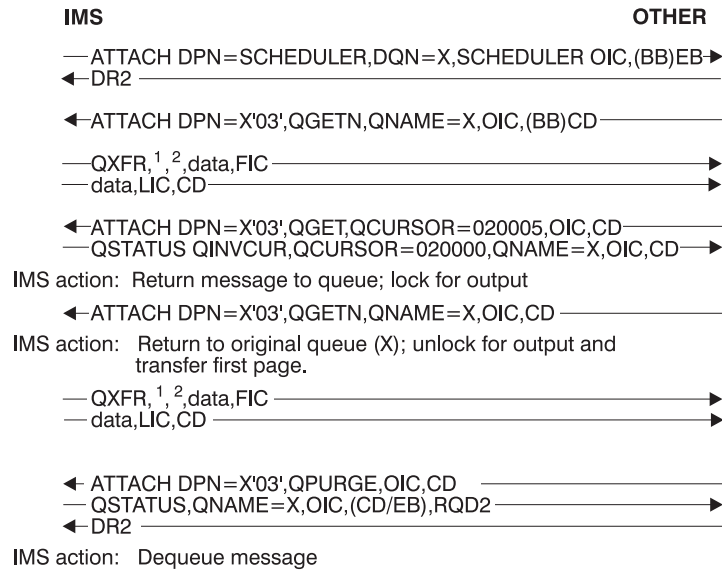

Figure 89. Example 3: Demand-Paged SCHEDULER Output, OLP Defined, QGET by Cursor Request for a Page Not within the Range of Output Message

**Notes:**

1. QCURSOR=0400010001, QCOUNT=020002
2. Data descriptor FM header can precede data

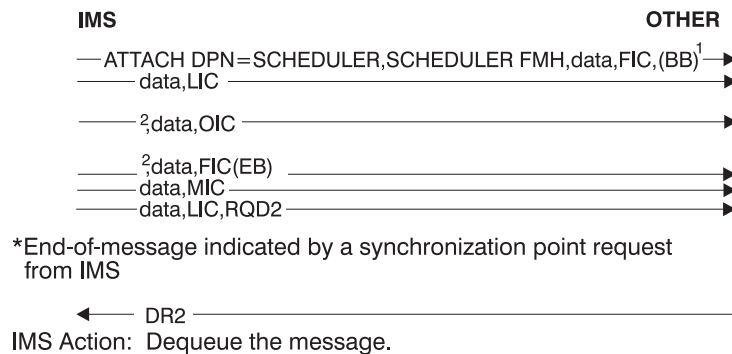

Figure 90. Example 4: Autopaged Output

**Notes:**

1. Sending a first-in-chain with BB on autopaged output requests DR1 (RQD1).
2. Data descriptor FM header can precede the data in each chain. The ATTACH indicates a multichain message.

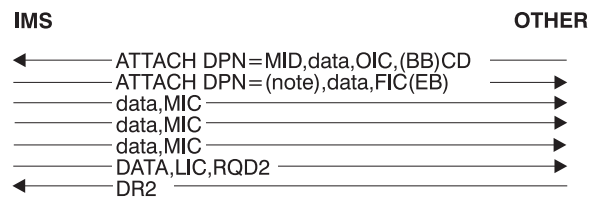

Figure 91. Example 5: Nonpaged Output Message

## MFS Bracket and Half-Duplex Protocol Examples

Data descriptor FM header can precede the data.

### MFS Input Examples

The following description is provided for examples 6 and 7, which are shown in Figure 92 and Figure 93 on page 585.

Three DPAGEs are defined:

- DPAGE 1 defines data for 2 segments
- DPAGE 2 defines data for 1 segment
- DPAGE 3 defines data for 3 segments

Three LPAGEs are created for the message. A data descriptor function management header with a DSN supplied with each chain is used to select each DPAGE. The first DSN name selects DPAGE 1, the second DSN name selects DPAGE 2, and the third DSN name selects DPAGE 3.

\*ATTACH and data for first DPAGE:

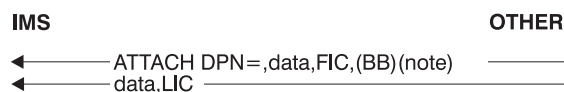

\*Data for second DPAGE:



\*Data for third DPAGE:

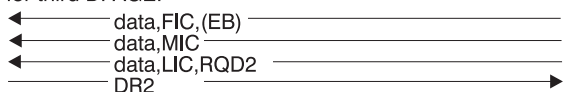

\*End-of-message is indicated via a sync-point request (RQD2) with data

- OR -

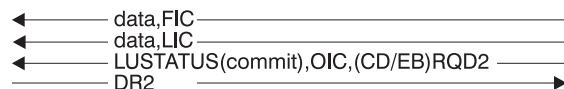

\*End-of message is indicated via a sync-point request (RQD2) in the subsequent RU without data

IMS action: Enqueue the input message.

*Figure 92. Example 6: Autopaged Input, Three Chains*

A data descriptor FM header can precede the data.

Three LPAGEs are created for the message. A conditional test on the data is performed to select each DPAGE. Results of first test selects DPAGE 1, results of the second test selects DPAGE 2, and results of the third test selects DPAGE 3.

## MFS Bracket and Half-Duplex Protocol Examples

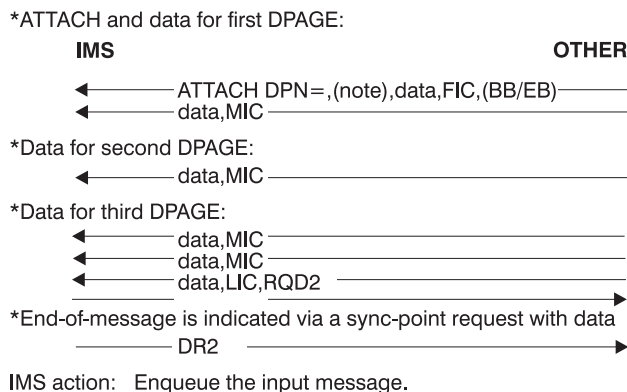

Figure 93. Example 7: Autopaged Input, Single Transmission Chain

The data descriptor FM header can be sent to select one DPAGE only. The ATTACH indicates a multichain message.

## SBI/BIS Examples

IMS can be either the primary half session (PHS) or the secondary half session (SHS) for all of the examples given. Therefore, all of the functions and commands shown for PHS and SHS are IMS functions and commands. Although all SBI and BIS sequences are valid for any session using LU 6.1 protocols, the following examples—shown in Figure 94, Figure 95 on page 586, and Figure 96 on page 586—assume IMS to be both the primary and the secondary half session. No assumptions are made here as to when or how a subsystem other than IMS might send or receive these sequences.

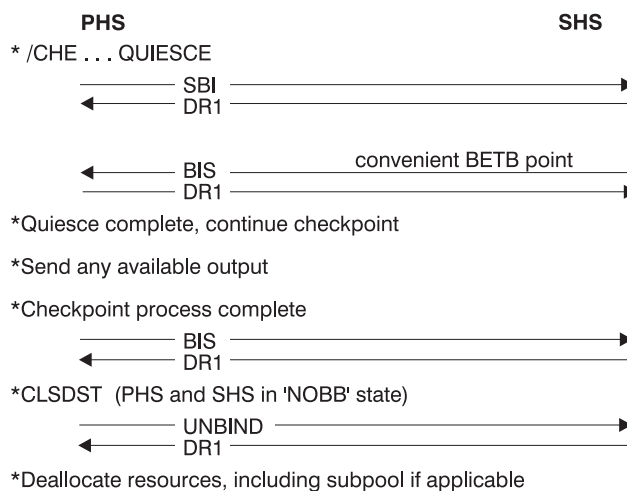

Figure 94. Example 1: PHS Shutdown Using SBI/BIS

## SBI/BIS Examples

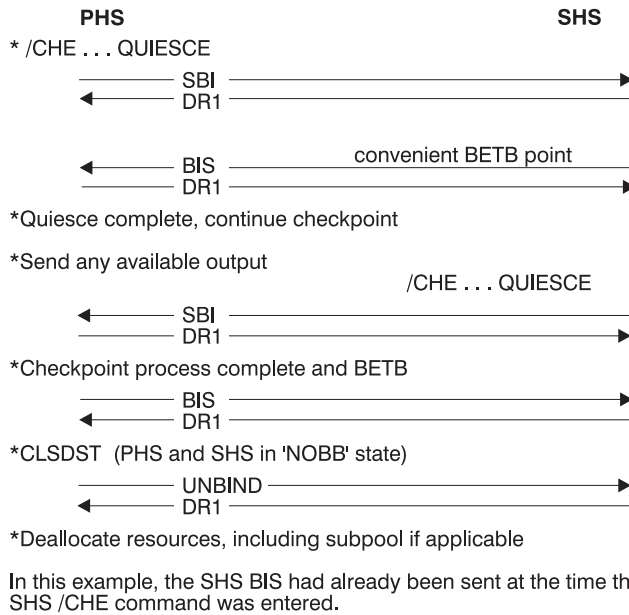

Figure 95. Example 2: Nonsimultaneous Shutdown Using SBI/BIS by Both Half Sessions

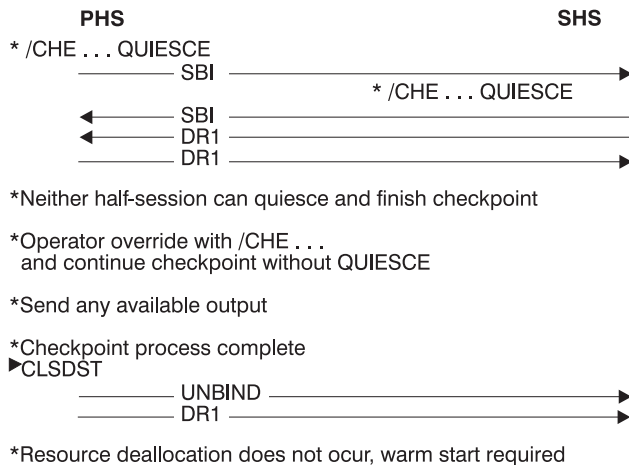

Figure 96. Example 3: Simultaneous PHS and SHS Shutdown Using SBI/BIS Fails Because of Operator Override

## Signal Protocol Example

The following example, shown in Figure 97 on page 587, illustrates the use of SIGNAL RCD.



## Signal Protocol Example

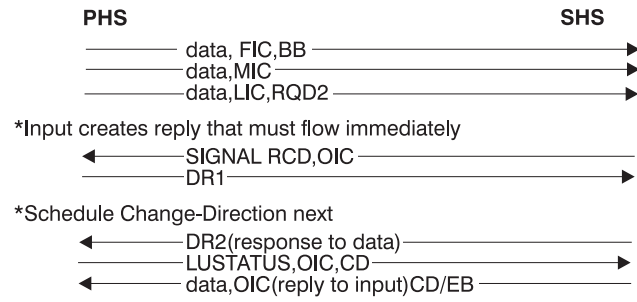

Figure 97. Signal Protocol Example

## Signal Protocol Example

## Appendix I. ISC Error Recovery Procedure Examples

This appendix provides ISC error recovery procedure examples.

### In this Appendix:

- “Sender-Detected Error Examples”
- “Receiver-Detected Error Examples” on page 590

### Sender-Detected Error Examples

Figure 98 and Figure 99 on page 590 show examples of sender-detected errors during paged output (or input). IMS is the sender in both figures.

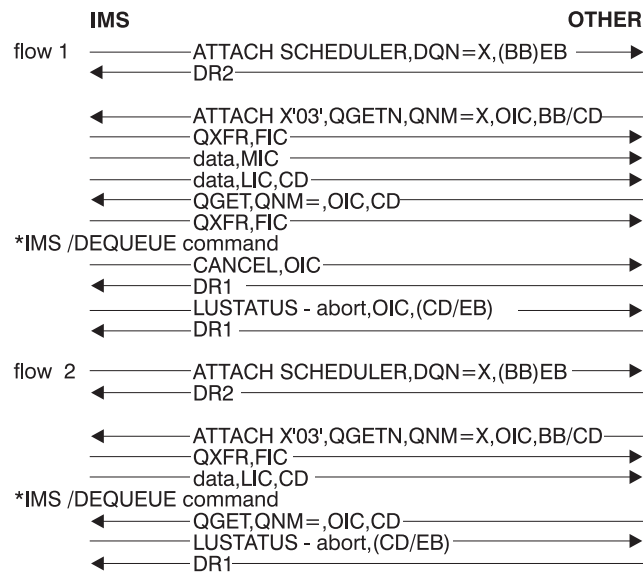

Figure 98. Example 1: Sender-Detected Error While Sending Demand-Paged Output Message

Flow 1 in Figure 96 shows an IMS /DEQUEUE command occurring during the second output demand page. The CANCEL command terminates the chain (page) in progress, and the LUSTATUS terminates the receiving process. If the paged output message follows another input or output message that began a bracket, the BB is not sent on the first page OIC.

Sample flow 2 is the same, except that the IMS /DEQUEUE command occurs between output pages so that the CANCEL command is unnecessary.

## Sender-Detected Error Examples

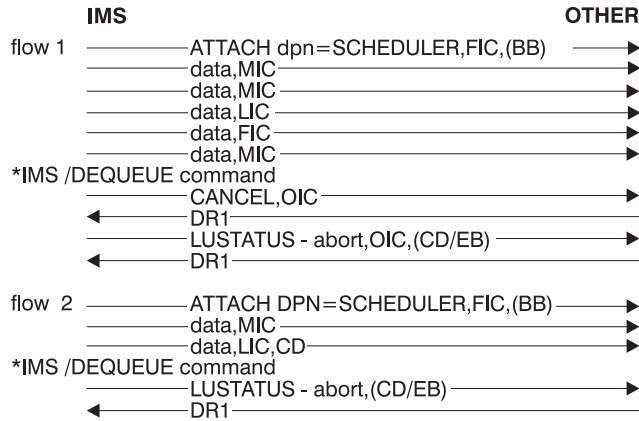

Figure 99. Example 2: Sender-Detected Error While Sending Autopaged Output Message

Again, the CANCEL command terminates the chain (page) in progress and the LUSTATUS terminates the receiving process. The initial begin-bracket and the resulting bracket send/receive protocol are the same as for demand-paged output in Figure 98 on page 589.

Flow 2 is the same as flow 1 in Figure 97, except that the IMS /DEQUEUE command occurs while between output pages, so that the CANCEL command is unnecessary.

## Receiver-Detected Error Examples

For simplicity, in Figure 100, Figure 101, Figure 102 on page 591, Figure 103 on page 591, and Figure 104 on page 591, all examples assume only-in-chain (OIC) messages for flows in both directions. Also the bracket and ERP protocol are considered symmetrical in that either half session can initiate the bracket or ERP procedures as illustrated.

For all session terminations not involving system failures, ATTACH information is recovered and backed up to the last sync point. In the examples that follow, IMS is the receiver.

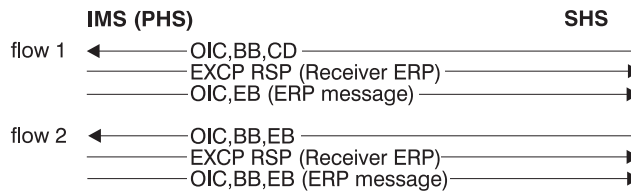

Figure 100. Example 1: Receiver ERP for an IMS Component Defined as SINGLE1

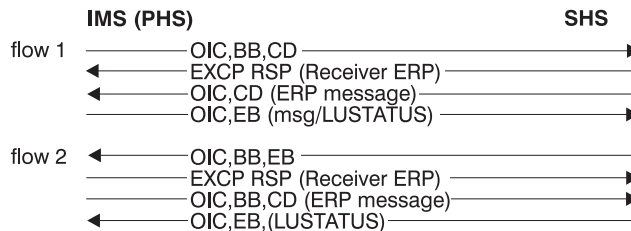

Figure 101. Example 2: Receiver ERP for an IMS Component Defined as SINGLE2

## Receiver-Detected Error Examples

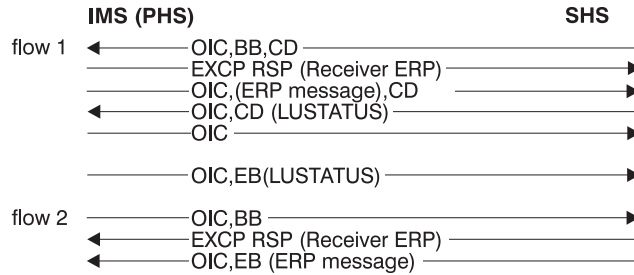

Figure 102. Example 3: Receiver ERP for an IMS Component Defined as MULT1

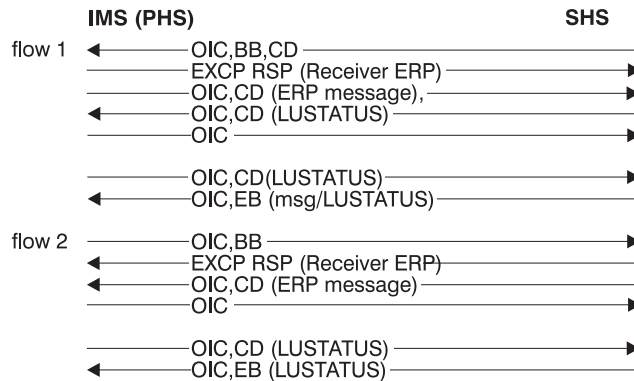

Figure 103. Example 4: Receiver ERP for an IMS Component Defined as MULT2

In this case, the receiver is the other subsystem. The IMS action follows selective receiver ERP sequence.

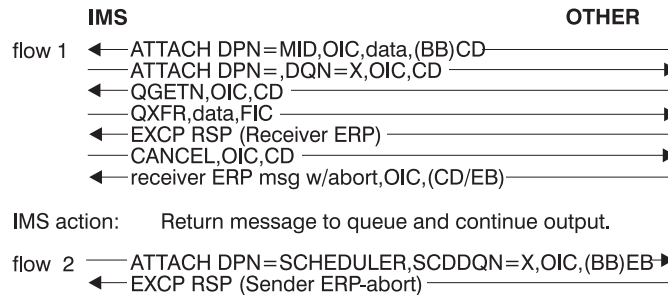

Figure 104. Example 5: Demand-Paged Output with Receiver-Detected Error

IMS action: Return message to queue and continue output.

In this example, flow 1 shows the receiver using receiver ERP to reject a demand-paged message. Flow 2 shows alternate methods with the same end result, but not involving an ERP message from the receiver.

## Receiver-Detected Error Examples

---

## Appendix J. Sample Program for IMS-CICS ISC

This appendix provides a sample program that illustrates the use of ISC between IMS and CICS. By combining it with the corresponding sample program in the *CICS Intercommunication Guide*, you can use the ISC function in both products.

The sample program is shipped as object and source code data set DFSISC00. The load library containing the object code is IMS.ADFSLOAD. The source library containing the source code is IMS.ADFSSRC.

### **In this Appendix:**

- “Installation Procedure”
- “IMS Sample Program (DFSISC00)”
- “Job Control Statements for the Sample Program” on page 596
- “IMS System Definition Statements” on page 596
- “MFS Formats” on page 597
- “Program Specification Block (PSB) Generation for the Sample Program” on page 598
- “Application Control Block (ACB) Generation” on page 599

---

## Installation Procedure

Before the sample program can be used to perform ISC functions between IMS and CICS, the following steps must be accomplished:

1. Compile and bind the sample COBOL program.
2. Define the transaction codes to IMS using the system definition procedure.
3. Define an ISC session between IMS and CICS using the system definition procedure.
4. Compile the MFS utility statements to place the necessary formats into the online library.
5. Perform the PSB generation and then the ACB generation.
6. Initialize the IMS system.
7. Establish a session between IMS and CICS.
8. Run the corresponding CICS sample program.

In this appendix, sample code is provided for performing steps 1 through 5.

---

## IMS Sample Program (DFSISC00)

The following IMS sample program, written in COBOL, accepts an input message from an ISC session with CICS and returns the same message to CICS. The program has two transaction codes—SAMPLA1 and SAMPLA2. When invoked using SAMPLA1, the output message is not formatted by MFS. When invoked using SAMPLA2, the output message is formatted by MFS using distributed presentation management (DPM).

**Related Reading:** To understand the source statements for the MFS utility, see “MFS Formats” on page 597.

## IMS Sample Program (DFSISC00)

```

CBL APOST
  IDENTIFICATION DIVISION.
    PROGRAM-ID. SAMPLA.
    AUTHOR:
  ENVIRONMENT DIVISION.
  CONFIGURATION SECTION.
  SOURCE-COMPUTER. IBM-370.
  OBJECT-COMPUTER. IBM-370.
  INPUT-OUTPUT SECTION.
  FILE-CONTROL.
  DATA DIVISION.
  FILE SECTION.
    EJECT
  WORKING-STORAGE SECTION.
  77 BEGIN-LIT          PIC X(16) VALUE 'BEGIN 77 ENTRIES'.
  77 FILLER             PIC X(45) VALUE
    '****DATE LAST COMPILED: xxx xx, 19xx****'.
  77 CALL-FUNCTION     PIC XXXX.
  77 MOD-NAME          PIC X(08).
    EJECT
  01 INPUT-AREA.
    02 IN-LL           PIC S9999 COMP.
    02 IN-ZZ           PIC S999 COMP.
    02 TRAN-CODE       PIC X(08).
    02 INPUT-DATA      PIC X(79).
    02 INPUT-DATA-D    REDEFINES INPUT-DATA.
      05 INPUT-DATA-1  OCCURS 3 TIMES
        PIC X(20).
      05 INPUT-DATA-2  PIC X(19).
  01 OUTPUT-AREA.
    02 OUT-LL          PIC S9999 COMP.
    02 OUT-ZZ          PIC S999 COMP.
    02 OUTPUT-DATA     PIC X(79).
  01 OUTPUT-AREA-1.
    02 OUT-LL-1        PIC S9999 COMP.
    02 OUT-ZZ-1        PIC S999 COMP.
    02 OUTPUT-DATA-1   PIC X(20).
    EJECT
  01 DLI-FUNCTIONS.
    02 GET-UNIQ        PIC XXXX VALUE 'GU '.
    02 GET-NEXT        PIC XXXX VALUE 'GN '.
    02 ISRT            PIC XXXX VALUE 'ISRT'.
    EJECT
  01 STATUS-ERROR-SEG.
    02 FILLER          PIC S999 COMP VALUE +83.
    02 FILLER          PIC S999 COMP VALUE +0.
    02 FILLER          PIC X(28) VALUE
    '***** STATUS ERROR *****'.
    02 FILLER          PIC X(10) VALUE ' TRANCODE:'.
    02 ERROR-TRAN      PIC X(8).
    02 FILLER          PIC X(17) VALUE
    ' STATUS RECEIVED:'.
    02 ERROR-STATUS    PIC XX.
    02 FILLER          PIC X(10) VALUE ' FUNCTION:'.
    02 ERROR-FUNCTION  PIC XXXX.
    EJECT
  LINKAGE SECTION.
  01 IOTP-PCB.
    02 IOTP-LTERM      PIC X(8).
    02 FILLER          PIC XX.
    02 IOTP-STATUS     PIC XX.
    02 IOTP-PREFIX.
      03 IOTP-DATE     PIC S9(7) COMP-3.
      03 IOTP-TIME     PIC S9(7) COMP-3.
      03 IOTP-MSG-NUMBER PIC S999 COMP.
      03 FILLER        PIC XX.
    02 IOTP-MOD-NAME   PIC X(8).

```



```

EJECT

PROCEDURE DIVISION.
  ENTRY 'DLITCBL' USING IOTP-PCB.
100-RETRIEVE-MESSAGE-SEGMENT.
  MOVE GET-UNIQ TO CALL-FUNCTION.
  CALL 'CBLTDLI' USING CALL-FUNCTION IOTP-PCB INPUT-AREA.
  IF IOTP-STATUS = 'QC'
    GO TO 800-GOBACK-ROUTINE.
  IF IOTP-STATUS NOT = SPACES
    GO TO 700-INVALID-STATUS-CODE.
200-CHECK-TRAN-CODE.
*****
*   THE ONLY DIFFERENCE BETWEEN THESE TWO TRANSACTIONS   *
*   IS THE ABSENCE OR PRESENCE OF MFS.  SAMPLA1 DOES NOT  *
*   CONTAIN MFS.  SAMPLA2 CONTAINS MFS.                  *
*****
  IF TRAN-CODE = 'SAMPLA2'
    PERFORM 400-SAMPLA2-ROUTINE
      THRU 450-SAMPLA2-ROUTINE-EXIT,
  ELSE
    PERFORM 300-SAMPLA1-ROUTINE
      THRU 350-SAMPLA1-ROUTINE-EXIT.
  GO TO 100-RETRIEVE-MESSAGE-SEGMENT.
EJECT

300-SAMPLA1-ROUTINE.
  MOVE ISRT TO CALL-FUNCTION.
  SUBTRACT 8 FROM IN-LL GIVING OUT-LL.
  MOVE IN-ZZ TO OUT-ZZ.
  MOVE INPUT-DATA TO OUTPUT-DATA.
  CALL 'CBLTDLI' USING CALL-FUNCTION IOTP-PCB OUTPUT-AREA.
  IF IOTP-STATUS NOT = SPACES
    GO TO 700-INVALID-STATUS-CODE.
350-SAMPLA1-ROUTINE-EXIT.
  EXIT.

400-SAMPLA2-ROUTINE.
  MOVE 'MODA' TO MOD-NAME,
  MOVE +0 TO OUT-ZZ-1.
  MOVE 24 TO OUT-LL-1.
  MOVE INPUT-DATA-1 (1) TO OUTPUT-DATA-1.
  PERFORM 500-INSERT-ROUTINE
    THRU 550-INSERT-ROUTINE-EXIT.
  SUBTRACT 20 FROM IN-LL.
  IF IN-LL IS LESS THAN 13 GO TO 450-SAMPLA2-ROUTINE-EXIT.
  MOVE INPUT-DATA-1 (2) TO OUTPUT-DATA-1.
  PERFORM 600-INSERT-ROUTINE
    THRU 650-INSERT-ROUTINE-EXIT.
  SUBTRACT 20 FROM IN-LL.
  IF IN-LL IS LESS THAN 13 GO TO 450-SAMPLA2-ROUTINE-EXIT.
  MOVE INPUT-DATA-1 (3) TO OUTPUT-DATA-1.
  PERFORM 600-INSERT-ROUTINE
    THRU 650-INSERT-ROUTINE-EXIT.
  SUBTRACT 20 FROM IN-LL.
  IF IN-LL IS LESS THAN 13 GO TO 450-SAMPLA2-ROUTINE-EXIT.
  MOVE INPUT-DATA-2 TO OUTPUT-DATA-1.
  PERFORM 600-INSERT-ROUTINE
    THRU 650-INSERT-ROUTINE-EXIT.
450-SAMPLA2-ROUTINE-EXIT.
  EXIT.
EJECT

500-INSERT-ROUTINE.
  MOVE ISRT TO CALL-FUNCTION.
  CALL 'CBLTDLI' USING CALL-FUNCTION IOTP-PCB OUTPUT-AREA-1
    MOD-NAME.
  IF IOTP-STATUS NOT = SPACES
    GO TO 700-INVALID-STATUS-CODE.

```

## IMS Sample Program (DFSISC00)

```
550-INSERT-ROUTINE-EXIT.  
EXIT.  
600-INSERT-ROUTINE.  
MOVE ISRT TO CALL-FUNCTION.  
CALL 'CBLTDLI' USING CALL-FUNCTION IOTP-PCB OUTPUT-AREA-1.  
IF IOTP-STATUS NOT = SPACES  
GO TO 700-INVALID-STATUS-CODE.  
650-INSERT-ROUTINE-EXIT.  
EXIT.  
700-INVALID-STATUS-CODE.  
MOVE CALL-FUNCTION TO ERROR-FUNCTION.  
MOVE IOTP-STATUS TO ERROR-STATUS.  
MOVE TRAN-CODE TO ERROR-TRAN.  
MOVE ISRT TO CALL-FUNCTION.  
CALL 'CBLTDLI' USING CALL-FUNCTION IOTP-PCB STATUS-ERROR-SEG.  
800-GOBACK-ROUTINE.  
GOBACK.
```

---

## Job Control Statements for the Sample Program

Use the following JCL to compile and bind the sample program. This JCL uses the z/OS COBOL 2.4 compiler and places the resulting load module in IMS.PGMLIB.

```
//IMSCOBOL JOB ACCT,NAME,CLASS=A,MSGLEVEL=(1,1),MSGCLASS=A  
// PROC MBR=,PAGES=60,RGN=512K,  
// SOUT=A  
//C EXEC PGM=IKFCBL00,REGION=&RGN,  
// PARM='SIZE=130K,BUF=10K,LINECNT=50,APOST,BATCH'  
//SYSLIN DD DSN=&&LIN,DISP=(MOD,PASS),UNIT=SYSDA,  
// DCB=(USER.PROCLIB),  
// SPACE=(3520,(40,10),RLSE,,ROUND)  
//SYSPRINT DD SYSOUT=&SOUT,DCB=(LRECL=121,BLKSIZE=605,RECFM=FBA),  
// SPACE=(605,(&PAGES.0,&PAGES),RLSE,,ROUND)  
//SYSUT1 DD UNIT=SYSDA,DISP=(,DELETE),  
// SPACE=(3520,(100,10),RLSE,,ROUND)  
//SYSUT2 DD UNIT=SYSDA,DISP=(,DELETE),  
// SPACE=(3520,(100,10),RLSE,,ROUND)  
//SYSUT3 DD UNIT=SYSDA,DISP=(,DELETE),  
// SPACE=(3520,(100,10),RLSE,,ROUND)  
//SYSUT4 DD UNIT=SYSDA,DISP=(,DELETE),  
// SPACE=(3520,(100,10),RLSE,,ROUND)  
//L EXEC PGM=IEWL,REGION=&RGN,PARM='XREF,LET,LIST',  
// COND=(4,LT,C)  
//*STEPLIB DD DSN=IMS.SDFSRESL,DISP=SHR  
//SYSLIB DD DSN=SYS1.COBLIB,DISP=SHR  
//SDFSRESL DD DSN=IMS.SDFSRESL,DISP=SHR  
//SYSLIN DD DSN=&&LIN,DISP=(OLD,DELETE),VOL=REF=*.C.SYSLIN  
// DD DSN=IMS.PROCLIB(CBLTDLI),DISP=SHR  
// DD DDNAME=SYSIN  
//SYSLMOD DD DSN=IMS.PGMLIB(&MBR),DISP=SHR  
//SYSPRINT DD SYSOUT=&SOUT,DCB=(RECFM=FBA,LRECL=121,BLKSIZE=605),  
// SPACE=(605,(&PAGES.0,&PAGES),RLSE,,ROUND)  
//SYSUT1 DD UNIT=(SYSDA,SEP=(SYSLMOD,SYSLIN)),DISP=(,DELETE),  
// SPACE=(3520,(100,10),RLSE,,ROUND)  
// PEND  
//IMSCOBOL EXEC IMSCOBOL,SOUT=A,MBR=SAMPLA  
//C.SYSLIN DD *
```

You can also bind the sample program directly from IMS.ADFSLOAD to IMS.PGMLIB.

---

## IMS System Definition Statements

Use the following statements to define to IMS the two transaction codes supported by the sample program:

```

APPLCTN PSB=SAMPLA
  TRANSACT CODE=SAMPLA1,INQ=(YES,NORECOV)
  TRANSACT CODE=SAMPLA2,INQ=NO
TYPE  UNITYPE=LUTYPE6,OPTIONS=(TRANRESP,OPNDST,NOMTOMSG,
                                SYNCSESS),
                                MSGDEL=SYSINFO,
                                OUTBUF=256,
                                SEGSIZE=256
                                X
                                X
                                X
                                X
*
**CICSA1 PARALLEL SESSION NODE
*
  TERMINAL NAME=CICSA1,
  SESSION=5,
  COMPT1=(SINGLE1,DPM-B1,IGNORE),
  COMPT2=(SINGLE2,DPM-B1,IGNORE),
  COMPT3=(MULT1,DPM-B1,IGNORE),
  COMPT4=(MULT2,DPM-B1,IGNORE)
                                X
                                X
                                X
                                X
                                X
VTAMPOOL
*
  SUBPOOL NAME=PS01
  NAME PSLT01,COMPT=1,ICOMPT=1
  NAME PSLT02,COMPT=2,ICOMPT=2
  NAME PSLT03,COMPT=3,ICOMPT=3
  NAME PSLT04,COMPT=4,ICOMPT=4

```

**Restriction:** The DPM-Bn specified here must match the DPM-Bn specified on the MFS format DEV statement.

## MFS Formats

These statements comprise the JCL and MFS statements needed to produce the MFS formats used by the sample program. This is shipped as copy code in data set MFSSISCO in IMS.ADFSMAC.

```

//MFSUTL JOB ACCT,NAME,CLASS=A,MSGLEVEL=(1,1)
//JOB LIB DD DSN=IMS.SDFSRESL,DISP=SHR
//      PROC RGN=360K,SOUT=A,SNODE=IMSVS,
//      SOR=NOLIB,MBR=NOMBR,PXREF=NOXREF,
//      PCOMP=NOCOMP,PSUBS=NOSUBS,PDIAG=NODIAG,
//      COMPR=NOCOMPRESS,COMPR2=COMPRESS,
//      LN=55,SN=8,DEVCHAR=0
//S1 EXEC PGM=DFSUPAA0,REGION=&RGN,
// PARM=(&PXREF,&PCOMP,&PSUBS,&PDIAG,&COMPR,
// 'LINECNT=&LN,STOPRC=&SN,DEVCHAR=&DEVCHAR')
//SYSLIB DD DSN=IMS.SDFSMAC,DISP=SHR
//SYSIN DD DSN=&SNODE..&SOR.(&MBR),DISP=SHR
//REFIN DD DSN=IMS.REFERAL,DISP=OLD
//REFOUT DD DSN=IMS.REFERAL,DISP=OLD
//REFRD DD DSN=IMS.REFERAL,DISP=OLD
//SYSTEXT DD DSN=&&TXTPASS,UNIT=SYSDA,
//      SPACE=(CYL,(1,1)),DCB=BLKSIZE=800
//SYSUT3 DD UNIT=SYSDA,SPACE=(CYL,(1,1))
//SYSUT4 DD UNIT=SYSDA,SPACE=(CYL,(1,1))
//UTPRINT DD SYSOUT=&SOUT
//SYSPRINT DD SYSOUT=&SOUT,DCB=(RECFM=FBA,LRECL=133,BLKSIZE=1330)
//SYSUDUMP DD SYSOUT=&SOUT
//SEQBLKS DD DSN=&&BLKS,DISP=(NEW,PASS),
//      UNIT=SYSDA,SPACE=(CYL,(1,1))
//S2 EXEC PGM=DFSUNUB0,REGION=&RGN,
// PARM='&COMPR2,DEVCHAR=&DEVCHAR',
//      COND=(8,LT,S1)
//SEQBLKS DD DSN=&&BLKS,DISP=(OLD,DELETE)
//UTPRINT DD SYSOUT=&SOUT,DCB=(RECFM=FBA,LRECL=133,BLKSIZE=1330)
//SYSUDUMP DD SYSOUT=&SOUT
//FORMAT DD DSN=IMS.FORMAT,DISP=OLD
//SYSPRINT DD SYSOUT=&SOUT

```

## MFS Formats

```
//SYSUT3 DD UNIT=SYSDA,SPACE=(CYL,(1,1))
//SYSUT4 DD UNIT=SYSDA,SPACE=(CYL,(1,1))
// PEND
//MFSUTL EXEC MFSUTL,SOUT=A
//S1.SYSIN DD *
        PRINT ON,NOGEN
FMTA    FMT
        SPACE 3
        DEV  TYPE=DPM-B1,FEAT=IGNORE,DSCA=X'00A0'
        SPACE 2
        DIV  TYPE=OUTPUT,OPTIONS=(DPAGE,NODNM)
        SPACE 3
DPAGE01 DPAGE FILL=NULL
PPAGE01 PPAGE
        DFLD 'PAGE'
LPGNO   DFLD LTH=04
        DFLD ' '
        SPACE 2
DATA01  DFLD LTH=20
        SPACE 3
        FMTEND
        EJECT
MODA    MSG  TYPE=OUTPUT,SOR=(FMTA,IGNORE),PAGE=YES
        SPACE 3
        SEG
        SPACE 2
        MFLD (LPGNO,LPAGENO)
        MFLD DATA01,LTH=20
        SPACE 3
        MSGEND
        END
/*
```

---

## Program Specification Block (PSB) Generation for the Sample Program

The following JCL and program specification block (PSB) generation statements produce the IMS control blocks necessary to execute the sample program:

```
//PSBGEN JOB ACCT,NAME,CLASS=A,MSGLEVEL=(1,1)
//      PROC  MBR=TEMPNAME,SOUT=A,RGN=2000K
//C      EXEC  PGM=IFOX00,REGION=&RGN,PARM='OBJ,NODECK'
//SYSLIB DD  DSN=IMS.SDFS MAC,DISP=SHR
//SYSGO  DD  UNIT=SYSDA,DISP=(,PASS),
//          SPACE=(80,(100,100),RLSE),
//          DCB=(BLKSIZE=80,RECFM=F,LRECL=80)
//SYSPRINT DD  SYSOUT=&SOUT,DCB=BLKSIZE=1089,
//          SPACE=(121,(300,300),RLSE,,ROUND)
//SYSUT1  DD  UNIT=SYSDA,DISP=(,DELETE),
//          SPACE=(1700,(100,50))
//SYSUT2  DD  UNIT=SYSDA,DISP=(,DELETE),
//          SPACE=(1700,(100,50))
//SYSUT3  DD  UNIT=(SYSDA,SEP=(SYSLIB,SYSUT1,SYSUT2)),
//          SPACE=(1700,(100,50))
//L      EXEC  PGM=IEWL,PARM='XREF,LIST',COND=(0,LT,C),REGION=120K
//STEPLIB DD  DSN=IMS.SDFSRESL,DISP=SHR
//SYSLIN  DD  DSN=*.C.SYSGO,DISP=(OLD,DELETE)
//SYSPRINT DD  SYSOUT=&SOUT,DCB=BLKSIZE=1089,
//          SPACE=(121,(90,90),RLSE)
//SYSLMOD DD  DSN=IMS.PSBLIB(&MBR),DISP=SHR
//SYSUT1  DD  UNIT=(SYSDA,SEP=(SYSLMOD,SYSLIN)),
//          SPACE=(1024,(100,10),RLSE),DISP=(,DELETE)
// PEND
//PSBGEN EXEC PSBGEN,SOUT=A,MBR=SAMPLA
//C.SYSIN DD *
        PSBGEN  LANG=COBOL,PSBNAME=SAMPLA
        END
/*
```

### Application Control Block (ACB) Generation

Use the following JCL and application control block (ACB) utility statements to place the PSB into the appropriate IMS online library:

```
//ACBGEN JOB ACCT,NAME,CLASS=A,MSGLEVEL=(1,1)
//ACBGEN EXEC ACBGEN,SOUT=A
//G.SYSIN DD *
BUILD PSB=SAMPLA
BUILD PSB=SAMPLB
/*
```

## Application Control Block (ACB) Generation

---

## Notices

This information was developed for products and services offered in the U.S.A. IBM may not offer the products, services, or features discussed in this document in other countries. Consult your local IBM representative for information on the products and services currently available in your area. Any reference to an IBM product, program, or service is not intended to state or imply that only that IBM product, program, or service may be used. Any functionally equivalent product, program, or service that does not infringe any IBM intellectual property right may be used instead. However, it is the user's responsibility to evaluate and verify the operation of any non-IBM product, program, or service.

IBM may have patents or pending patent applications covering subject matter described in this document. The furnishing of this document does not give you any license to these patents. You can send license inquiries, in writing, to:

IBM Director of Licensing  
IBM Corporation  
North Castle Drive  
Armonk, NY 10504-1785  
U.S.A.

For license inquiries regarding double-byte (DBCS) information, contact the IBM Intellectual Property Department in your country or send inquiries, in writing, to:

IBM World Trade Asia Corporation  
Licensing  
2-31 Roppongi 3-chome, Minato-ku  
Tokyo 106, Japan

**The following paragraph does not apply to the United Kingdom or any other country where such provisions are inconsistent with local law:**

INTERNATIONAL BUSINESS MACHINES CORPORATION PROVIDES THIS PUBLICATION "AS IS" WITHOUT WARRANTY OF ANY KIND, EITHER EXPRESS OR IMPLIED, INCLUDING, BUT NOT LIMITED TO, THE IMPLIED WARRANTIES OF NON-INFRINGEMENT, MERCHANTABILITY OR FITNESS FOR A PARTICULAR PURPOSE. Some states do not allow disclaimer of express or implied warranties in certain transactions, therefore, this statement may not apply to you.

This information could include technical inaccuracies or typographical errors. Changes are periodically made to the information herein; these changes will be incorporated in new editions of the publication. IBM may make improvements and/or changes in the product(s) and/or the program(s) described in this publication at any time without notice.

Any references in this information to non-IBM Web sites are provided for convenience only and do not in any manner serve as an endorsement of those Web sites. The materials at those Web sites are not part of the materials for this IBM product and use of those Web sites is at your own risk.

IBM may use or distribute any of the information you supply in any way it believes appropriate without incurring any obligation to you.

Licensees of this program who wish to have information about it for the purpose of enabling: (i) the exchange of information between independently created programs and other programs (including this one) and (ii) the mutual use of the information which has been exchanged, should contact:

IBM Corporation  
J46A/G4  
555 Bailey Avenue  
San Jose, CA 95141-1003  
U.S.A.

Such information may be available, subject to appropriate terms and conditions, including in some cases, payment of a fee.

The licensed program described in this information and all licensed material available for it are provided by IBM under terms of the IBM Customer Agreement, IBM International Program License Agreement, or any equivalent agreement between us.

Any performance data contained herein was determined in a controlled environment. Therefore, the results obtained in other operating environments may vary significantly. Some measurements may have been made on development-level systems and there is no guarantee that these measurements will be the same on generally available systems. Furthermore, some measurement may have been estimated through extrapolation. Actual results may vary. Users of this document should verify the applicable data for their specific environment.

Information concerning non-IBM products was obtained from the suppliers of those products, their published announcements or other publicly available sources. IBM has not tested those products and cannot confirm the accuracy of performance, compatibility or any other claims related to non-IBM products. Questions on the capabilities of non-IBM products should be addressed to the suppliers of those products.

All statements regarding IBM's future direction or intent are subject to change or withdrawal without notice, and represent goals and objectives only.

This information is for planning purposes only. The information herein is subject to change before the products described become available.

This information contains examples of data and reports used in daily business operations. To illustrate them as completely as possible, the examples include the names of individuals, companies, brands, and products. All of these names are fictitious and any similarity to the names and addresses used by an actual business enterprise is entirely coincidental.

#### COPYRIGHT LICENSE:

This information contains sample application programs in source language, which illustrates programming techniques on various operating platforms. You may copy, modify, and distribute these sample programs in any form without payment to IBM, for the purposes of developing, using, marketing or distributing application programs conforming to the application programming interface for the operating platform for which the sample programs are written. These examples have not been thoroughly tested under all conditions. IBM, therefore, cannot guarantee or imply reliability, serviceability, or function of these programs. You may copy, modify, and distribute these sample programs in any form without payment to



IBM for the purposes of developing, using, marketing, or distributing application programs conforming to IBM's application programming interfaces.

Each copy or any portion of these sample programs or any derivative work, must include a copyright notice as follows:

© (your company name) (year). Portions of this code are derived from IBM Corp. Sample Programs. © Copyright IBM Corp. \_enter the year or years\_. All rights reserved.

If you are viewing this information softcopy, the photographs and color illustrations may not appear.

---

## Programming Interface Information

This book is intended to help system programmers administer an IMS Transaction Manager network. This book documents General-use Programming Interface and Associated Guidance Information provided by IMS.

General-use programming interfaces allow the customer to write programs that obtain the services of IMS.

---

## Trademarks

The following terms are trademarks of the IBM Corporation in the United States or other countries or both:

BookManager	Parallel Sysplex
CICS	PS/2
DataPropagator	QMF
DB2	RACF
DB2 Universal Database	S/390
ES/9000	SAA
IBM	SP
IMS	Tivoli
MVS	VM/ESA
NetView	VTAM
OS/390	WebSphere
	z/OS

Java and all Java-based trademarks and logos are trademarks of Sun Microsystems, Inc., in the United States, other countries, or both.

UNIX is a trademark of The Open Group in the United States and other countries.

Other company, product, and service names may be trademarks or service marks of others.



---

## Bibliography

This bibliography lists all of the information in the IMS Version 9 library.

- *ACF/VTAM System Programmer's Guide*, SC38-0258
- *Advanced Function for Communication System Summary*, GA27-3099
- *BTAM SP™ Program Summary*, GC27-0599
- *CICS Transaction Server for z/OS V2.2: CICS Application Programming Reference*, SC34-5994
- *CICS Transaction Server for z/OS V2.2: CICS Customization Guide*, SC34-5989
- *CICS Transaction Server for z/OS V2.2: CICS Intercommunication Guide*, SC34-6005
- *CICS Transaction Server for z/OS V2.2: CICS Operations and Utilities Guide*, SC34-5991
- *CICS Transaction Server for z/OS V2.2: CICS Recovery and Restart Guide*, SC34-6008
- *CICS Transaction Server for z/OS V2.2: CICS Resource Definition Guide*, SC33-1166
- *CICS Transaction Server for z/OS V2.2: CICS Supplied Transactions*, SC34-5992
- *Common Programming Interface Communications Specification*, SC31-6180
- *DB2 Universal Database for z/OS: Application Programming and SQL Guide*, SC18-7415
- *IBM 3270 Information Display System: 3274 Control Unit Description and Programmer's Guide*, GA23-0061
- *IBM 4700 Finance Communication System: Controller Programming Library, Volume 3: Communication Program*, GC31-2068
- *IBM 4700 Finance Communication System: System Summary*, GC27-2016
- *IBM 4730 Personal Banking Machine General Information*, GC31-2073
- *IBM 4730 Personal Banking Machine Operations Support Manual*, GC31-2560
- *IBM IMS Queue Control Facility for z/OS User's Guide*, SC26-9685
- *MVS/ESA Planning: Extended Recovery Facility (XRF)*, GC28-1139
- *Network Program Products General Information*, GC30-3350
- *Network Program Products Planning*, SC30-3351
- *SAA CPI Communications Reference*, SC26-4399
- *SAA CPI Resource Recovery Reference*, SC31-6821
- *Screen Definition Facility II General Information*, GH19-6114
- *System/7 Functional Characteristics Manual*, GA34-0003-07
- *Systems Network Architecture Format and Protocol Reference: Architectural Logic*, SC30-3112-02
- *Systems Network Architecture: Sessions between Logical Unit Types*, GC20-1868
- *Systems Network Architecture Technical Overview*, GC30-3073-04
- *z/OS V1R4: Communications Server: SNA Customization*, LY43-0092
- *z/OS V1R4: Communications Server: SNA Network Implementation*, SC31-8777
- *z/OS V1R4: Communications Server: SNA Operation*, SC31-8779
- *z/OS V1R2: Communications Server: SNA Programming*, SC31-6550
- *z/OS V1R4: Communications Server: SNA Resource Definition Reference*, SV40-1012
- *z/OS V1R4: MVS Dump Output Messages*, SA22-7590
- *z/OS V1R4: MVS Planning: APPC Management*, SA22-7599
- *z/OS V1R4: MVS Planning: Workload Management*, SA22-7602
- *z/OS V1R4: MVS Programming: Sysplex Services Guide*, SA22-7617
- *z/OS V1R4: MVS Programming: Workload Management Services*, SA22-7619
- *z/OS V1R2: MVS Programming: Writing Transaction Programs for APPC/MVS*, SA22-7621
- *z/OS V1R4: MVS System Messages, Vol 3 (ASB-BPX)*, SA22-7633
- *z/OS V1R4: Parallel Sysplex Overview: Introducing Data Sharing and Parallelism in a Sysplex*, SA22-7661

---

## IMS Version 9 Library

Title	Acronym	Order number
<i>IMS Version 9: Administration Guide: Database Manager</i>	ADB	SC18-7806

Title	Acronym	Order number
<i>IMS Version 9: Administration Guide: System</i>	AS	SC18-7807
<i>IMS Version 9: Administration Guide: Transaction Manager</i>	ATM	SC18-7808
<i>IMS Version 9: Application Programming: Database Manager</i>	APDB	SC18-7809
<i>IMS Version 9: Application Programming: Design Guide</i>	APDG	SC18-7810
<i>IMS Version 9: Application Programming: EXEC DLI Commands for CICS and IMS</i>	APCICS	SC18-7811
<i>IMS Version 9: Application Programming: Transaction Manager</i>	APTM	SC18-7812
<i>IMS Version 9: Base Primitive Environment Guide and Reference</i>	BPE	SC18-7813
<i>IMS Version 9: Command Reference</i>	CR	SC18-7814
<i>IMS Version 9: Common Queue Server Guide and Reference</i>	CQS	SC18-7815
<i>IMS Version 9: Common Service Layer Guide and Reference</i>	CSL	SC18-7816
<i>IMS Version 9: Customization Guide</i>	CG	SC18-7817
<i>IMS Version 9: Database Recovery Control (DBRC) Guide and Reference</i>	DBRC	SC18-7818
<i>IMS Version 9: Diagnosis Guide and Reference</i>	DGR	LY37-3203
<i>IMS Version 9: Failure Analysis Structure Tables (FAST) for Dump Analysis</i>	FAST	LY37-3204
<i>IMS Version 9: IMS Connect Guide and Reference</i>	CT	SC18-9287
<i>IMS Version 9: IMS Java Guide and Reference</i>	JGR	SC18-7821
<i>IMS Version 9: Installation Volume 1: Installation Verification</i>	IIV	GC18-7822
<i>IMS Version 9: Installation Volume 2: System Definition and Tailoring</i>	ISDT	GC18-7823
<i>IMS Version 9: Master Index and Glossary</i>	MIG	SC18-7826
<i>IMS Version 9: Messages and Codes, Volume 1</i>	MC1	GC18-7827
<i>IMS Version 9: Messages and Codes, Volume 2</i>	MC2	GC18-7828
<i>IMS Version 9: Open Transaction Manager Access Guide and Reference</i>	OTMA	SC18-7829
<i>IMS Version 9: Operations Guide</i>	OG	SC18-7830

Title	Acronym	Order number
<i>IMS Version 9: Release Planning Guide</i>	RPG	GC17-7831
<i>IMS Version 9: Summary of Operator Commands</i>	SOC	SC18-7832
<i>IMS Version 9: Utilities Reference: Database and Transaction Manager</i>	URDBTM	SC18-7833
<i>IMS Version 9: Utilities Reference: System</i>	URS	SC18-7834

---

## Supplementary Publications

Title	Order number
<i>IMS Connector for Java 2.2.2 and 9.1.0.1 Online Documentation for WebSphere Studio Application Developer Integration Edition 5.1.1</i>	SC09-7869
<i>IMS Version 9 Fact Sheet</i>	GC18-7697
<i>IMS Version 9: Licensed Program Specifications</i>	GC18-7825

---

## Publication Collections

Title	Format	Order number
<i>IMS Version 9 Softcopy Library</i>	CD	LK3T-7213
<i>IMS Favorites</i>	CD	LK3T-7144
<i>Licensed Bill of Forms (LBOF): IMS Version 9 Hardcopy and Softcopy Library</i>	Hardcopy and CD	LBOF-7789
<i>Unlicensed Bill of Forms (SBOF): IMS Version 9 Unlicensed Hardcopy Library</i>	Hardcopy	SBOF-7790
<i>OS/390 Collection</i>	CD	SK2T-6700
<i>z/OS Software Products Collection</i>	CD	SK3T-4270
<i>z/OS and Software Products DVD Collection</i>	DVD	SK3T-4271

---

## Accessibility Titles Cited in This Library

Title	Order number
<i>z/OS V1R1.0 TSO Primer</i>	SA22-7787
<i>z/OS V1R5.0 TSO/E User's Guide</i>	SA22-7794
<i>z/OS V1R5.0 ISPF User's Guide, Volume 1</i>	SC34-4822

# Index

## Special characters

/ASSIGN command  
  cold starting ISC sessions 306  
  ETO limitations 182  
/CHANGE command, initiating an ISC session 306  
/DEQUEUE command 232, 306, 323  
/DISPLAY command 68, 230, 306  
  MSC 230  
  pending ISC output 306  
  QSTOP state 68  
/EXIT command 37, 320  
/IDLE command 228  
/MSASSIGN command 199, 228  
/MSVERIFY command 224, 225  
  dynamic validation 224  
  error responses 225  
/OPNDST command 63, 173, 182  
/PSTOP LINK command 227  
/RSTART LINK command 227, 229  
/SIGN command for ETO STSN devices 192  
/START command 65, 463  
  making IMS ready 65  
/STOP command 38

## Numerics

3270 copy command 91  
3600 terminal, supported as Finance or SLU P 436  
3650 system, supported as SLU P 436  
4700 terminals, supported as Finance or SLU P 436  
4730 Personal Banking Machine, connecting in the XRF environment 442  
8100 system, supported as SLU P 436

## A

abend  
  CICS 575  
  IMS 575  
  MSC conversations 217  
accessibility xviii  
  keyboard xix  
  shortcut keys xix  
ACK option  
  Finance Communication System 489, 490  
  SLU P 489, 490  
administration  
  ETO 147  
  IMS, in client/server environment 395  
  ISC 253  
  MFS 78  
  MSC (multiple systems coupling) 213

administration (*continued*)  
  SLU P and Finance communication 435  
affinity  
  definition 17  
  in an MSC-IMSplex configuration 239  
  management, bypassing 128  
allocating a session, CICS 555  
alternate facility, CICS 559  
alternate PCB, secondary transaction 30  
alternate response PCB  
  message switches, use 276  
  modifying 446  
  use 446  
AOI transactions  
  scheduling 117  
API (application program interface)  
  explicit 7  
  implicit 7  
API (application program interface), ISC  
  IMS use of VTAM 265  
API (application program interface), ISC (intersystem communication)  
  asynchronous, CICS 536, 557  
  synchronous, CICS 536, 557  
APPC (advanced program-to-program communication)  
  APPC/IMS 27  
  communications manager as the 402 descriptor  
    as a TM resource 131  
  destination code 28  
  destination structure 28  
  DFSAPPC 27  
  editing and formatting 73  
  generic resource name, specifying 123  
  IMS messages 27  
  input segment 28  
  LU 6.2 messages 27  
  queuing, SERIAL=YES option 27  
  segments, single or multiple 28  
  structure 28  
  switching 32  
  SYNCLVL=SYNCPT 402  
  types 27  
APPC (advanced program-to-program communication)/IMS 7  
  API 7  
    explicit 7, 406  
    implicit 7, 406  
  application programs  
    CPI-C driven 407  
    modified IMS 407  
    remote standard IMS 409  
    standard IMS 407  
  asynchronous output delivery 430  
  CPI Communications application program 395  
  CPI-C initialization 26

APPC (advanced program-to-program communication)/IMS (*continued*)  
  default conversation characteristics 430  
  DFSAPPC 427  
    message switching 428  
    option keywords 428  
  discardable messages 407  
  establishing APPC/IMS 412  
    APPC=Y or N 412  
    system definition 412  
  introduction 405  
  local service for remote APPC transaction 408, 410  
  LTERM interface 411  
  LU 6.2  
    devices 7  
    relationship to APPC/IMS 405  
    terminal support 26  
  LUADD option keywords 417  
  MOD name 411  
  mode name 416  
  modified IMS application programs 409  
  MSC 420  
    recovering transactions in APPC 420  
    standard IMS applications 408  
  MSC (Multiple Systems Coupling) processing remote transactions in an IMSplex 245  
  MSC and modified IMS applications 410  
  MVS System File Manager utility example (ATBSDFMU) 414  
  network-qualified LU name 427  
  nondiscardable messages 407  
  PARMLIB 416  
  partner LU name 416  
  RACF 431  
  recoverability 67  
  recoverable versus irrecoverable transactions 420  
  remote service for remote APPC transaction 410  
  restrictions 408  
  security 431  
  shared-queues environment 115  
    asynchronous messages 115  
    synchronous messages 115  
  SIADD 416  
  side information 26  
    mode\_name 26, 415  
    partner\_LU\_name 26, 415  
    TP\_name 26, 415  
  sym\_dest\_name 416  
  Sync\_Level options (NONE, CONFIRM, SYNCPT) 408, 409  
  SYS1.APPCSI 416  
  SYS1.APPCTP 413

APPC (advanced program-to-program communication)/IMS (*continued*)  
 SYS1.PARMLIB(APPCPMxx)  
 example 416  
 TP name 416  
 TP Profile 410  
 ATBDFMU utility 412  
 definition 410  
 DFSTPPE0 414  
 DFSTPROF 414  
 dialog example 413  
 TSO ICQASRM0 413  
 VSAM data set 412  
 TPN (transaction program name) 415, 428  
 transaction retry characteristics 426  
 deadlock 426  
 Fast Path retry conditions 426  
 lock reject 426  
 transaction security 431  
 ACCESS (EXECUTE) 431  
 UACC (NONE) 431  
 XRF 426  
 application program interface  
*See* API (application program interface)  
 application programs  
 abnormal termination and MSC 232  
 CICS, with IMS 556  
 converting Finance to SLU P 438  
 definition 5  
 existing programs, with ISC 278, 280  
 functions IMS provides 7  
 ISC sample 593  
 remote 6  
 SLU P controller 438  
 XRF considerations, SLU P 438  
 APPLID name  
 in a generic resources environment 124  
 APPLID= parameter, ISC session  
 definition 293  
 asynchronous processing  
 ATTACH EB 272  
 IMS-CICS session 543  
 ISC execution mode 272  
 SCHEDULER FM header 360  
 ATCCONxx member (VTAM nodes) 64  
 ATCSTRyy member (VTAM start lists) 64  
 ATTACH FM header  
 bit contents 373, 375  
 format 373, 381  
 MFS 367  
 parameter description 375, 381  
 process initiation 358  
 with CICS 564  
 ATTACH FM headers  
*See also* synchronous processing  
 EB indicator 272  
 ATTIU parameter, FM header length 359  
 autologon terminal  
 shared queues 99  
 automated operator programs 20  
 autopaged output, synchronous 539

## B

back-end IMS  
 in a shared queues environment 96  
 back-end subsystem  
 CICS 542  
 definition 255  
 IMS 539, 541  
 routing transactions 290  
 backout work unit, message  
 resynchronization 304  
 balancing group  
 definition 19  
 routing codes and 19  
 balancing resource demand in MSC  
 (multiple systems coupling) 214  
 basic edit 74  
 bypassing 86  
 editing options with ISC 84  
 IMS functions 83  
 IMS systems 74  
 input message segments 87  
 input messages 83  
 ISC messages 270  
 non-MFS programs 279  
 output message segments 87  
 output messages 84  
 SLU 1 transparent data 84  
 Basic Telecommunications Access Method (BTAM)  
 IMSplex, in an 131  
 BB (begin bracket) indicator  
 definition 277  
 LUSTATUS command 343  
 use (figure) 443  
 begin bracket indicator  
 LUSTATUS command 343  
 use (figure) 443  
 BID command 330, 449, 458  
 BID option  
 caused by session termination 492  
 design considerations 449, 458  
 effects  
 display screen protection 453  
 MFS paging 452  
 output messages 450  
 bind  
 action/response matrix 310  
 IMS-CICS session 572  
 ISC session  
 parallel 303  
 single 303  
 negotiable 303  
 nonnegotiable 303  
 parameters  
 Finance Communication System 503  
 ISC, IMS as primary half session 505  
 ISC, IMS as secondary half session 510  
 SLU 1 515  
 SLU P 503  
 rejected, ISC 351  
 requesting asynchronous process 360  
 BIND race 304  
 BINPDSB1= parameter, BINTRNDS  
 option 84

BIS (bracket initiation stopped) command  
 IMS-CICS session 556  
 session shutdown 355  
 bracket and send/receive management  
 Finance Communication System  
 direction indicators 443  
 protocol 443  
 ISC, how determined 276  
 SLU P  
 direction indicators 443  
 bracket contention  
 invalid paging 457  
 resolving 304, 456  
 bracket initiation stopped (BIS) command  
 IMS-CICS session 556  
 session shutdown 355  
 bracket protocol  
 IMS 330, 473  
 input bracketing 478  
 input messages, ISC 330  
 output bracketing 485  
 output messages, ISC 333  
 bracket rejection  
 Finance Communication System 464, 492  
 ISC 352  
 SLU P 464, 492  
 BREAK code X'0811'  
 actions taken 492  
 output messages 492  
 BTAM (Basic Telecommunications Access Method)  
 IMSplex, in an 131  
 buffer  
 MSC (multiple systems coupling)  
 considerations 214  
 MSC (multiple systems coupling)  
 linking 198  
 buffer sizes  
 BUFSIZE parameter 219  
 IMS-to-IMS sessions 289  
 ISC 295  
 MSC LU 6.2 application  
 transactions 219  
 MSC non-VTAM links 219  
 MSC VTAM links 219  
 BUFSIZE parameter for MSC LU 6.2 219

## C

callable services  
 global 130  
 CANCEL command  
 paging errors 346, 353  
 protocol 338  
 sender ERP 351  
 SLU P session 494  
 candidate printers 91  
 CD (change direction) indicator 330  
 definition 277  
 Finance Communication System 441  
 LUSTATUS command 343  
 send/receive protocol 443, 473  
 SLU P 441  
 soliciting 325  
 CFRM policy  
 defining 103

- CFRM policy (*continued*)
  - example 105
- chained message communication
  - sequence 479
- chains, logical terminal 33
- CHANGE command, initiating an ISC session 306
- change direction (CD) indicator
  - Finance Communication System 441
  - send/receive protocol 443, 473
  - SLU P 441
- channel-to-channel (CTC)
  - MSC (multiple systems coupling)
    - physical link type 198
- character string controls 523
- CHASE command 339
- checkpoint
  - IMSplex, in an 135
- CICS resource definition 547
- CICS-IMS communication
  - alternate facility 559
  - application coding for 556
  - asynchronous processing flow 543
  - ATTACH parameters 564
  - CICS transactions 554
  - coding function management
    - headers 564
  - coding system definition options 546
  - Command Level API 536
  - configuration 258
  - conversation mode 560
  - defining CICS transactions 554
  - device mapping function 258
  - facility
    - alternate 559
    - principal 559
  - functions
    - description 535, 537
    - overview 259
  - IMS commands 561
  - initiating sessions 555
  - integrity of session 572
  - LU 6.1 links
    - compatible nodes 548
    - description 547
    - Macro-Level Resource Definition 547
    - multiple links 552
    - Resource Definition Online 547
  - MFS support 569
  - mirror transaction 543
  - MSC links 259
  - passing data to IMS with ISC 261
  - preparing CICS tables 547
  - principal facility 559
  - processing flows
    - RECEIVE 542
    - RETRIEVE 544
    - SEND INVITE 539
    - SEND LAST 541
    - SEND/RECEIVE 540
    - START/RETRIEVE 544
  - recovery and restart 570
  - SCHEDULER parameters 567
  - session
    - binding 572
    - initiation 555
- CICS-IMS communication (*continued*)
  - session (*continued*)
    - integrity 572
    - processing outstanding traffic 573
    - reestablishing 572
    - resynchronizing 572
    - sync points 562
    - termination 556
  - sync points 562
  - transactions
    - abnormal termination 558, 575
    - attributes supported 537, 558
    - definition 554
- CICS-ISC installation options 546
- Class 1 terminals
  - overview 51
  - status recovery modes 42
  - XRF support 51
- Class 2 terminals
  - overview 52
  - status recovery modes 43
  - XRF support 51
- Class 3 terminals
  - overview 53
  - XRF support 51
- cloned configuration
  - shared queues 101
- cloning
  - a shared-queues configuration 101
- coding CICS
  - applications for ISC 556
  - system definition macros 546
  - tables 547
- coexistence
  - IMSplex and MSC 237
  - MSC and IMSplex 237
- cold start
  - general considerations 227
  - message integrity 232
  - MSC 227, 232
- cold start, recovering ISC sessions 306
- COMM macro statement 293
  - APPLID= keyword 60
  - PASSWD= keyword 60
  - RECANY= keyword 61
- Command Level API, CICS 536
- commands
  - affecting MSC operation 228
  - asynchronous reply 539
  - CICS EXEC
    - asynchronous API 536
    - creating DFC protocols 536
    - functions available 537
    - program flow 539
  - CICS-IMS session 561
  - IMS
    - parallel ISC sessions 270
    - start system 65
  - issuing from an ISC session 270
  - keywords 228
  - LUSTATUS protocol, ISC 345
  - PRNs, not specified on IMS
    - commands 379
  - recovery at ISC session failure 308
  - response requirements 490
  - transaction reply 540
  - used to start system 463
- commands (*continued*)
  - VTAM
    - BID 449
    - BIS 355, 556
    - CANCEL 338, 494
    - CHASE 339
    - commands and indicators 264, 439
    - LUSTATUS command 343, 493
    - LUSTATUS with CICS 539, 560
    - ready to receive (RTR) 346
    - Request-Recovery 494
    - RSHUT 347
    - RTR 493
    - SIGNAL 355, 494
- commit
  - LUSTATUS command 345
  - work unit 304, 570
- Common Queue Server (CQS)
  - access with IMS commands 111
  - checkpoint data set 14
  - client
    - exit routines 15
  - client, definition 12
  - cold start 109
  - coupling facility
    - changing structure size 109
  - definitions 12
    - execution parameters 106
    - global structure parameters 106
    - initialization parameters 106
    - local structure parameters 106
  - list structures
    - planning 112
  - logging
    - OC/390 logger 110
  - overview 15
  - restarting 108
    - after system checkpoint 109
  - shared queue environment, in a 13
  - shutting down 110
  - starting 108
  - structures
    - checkpoint, initiating 109
    - copying 110
    - rebuilding 109
    - recovering 109, 110
  - system checkpoint
    - data sets 109
    - initiating 109
    - restart 109
  - user-supplied exit routines 109
  - using 108
  - warm start 108
    - log token 108
- communications controller 5, 6
- communications network 3
  - components
    - responsibilities 4, 19
    - Finance Communication System 436
    - SLU P system 436
- communications, establishing 11
- COMPINOP state 39
- component definition
  - LTERM naming 274, 445
  - parameter definitions 334

- component definition (*continued*)
    - selection
      - input component 275, 445
      - output component 277, 278, 446
      - SLU P input component 446
    - SLU P system 445
  - component protection
    - extended output 453
    - state 39
  - configurations
    - Finance Communication System 436
    - ISC 258, 259
    - SLU P system 436
    - VTAM 64
  - connecting multiple IMS systems 213
  - connection
    - description 265, 441
    - IMS session parameters
      - ISC 301, 302
      - restriction against altering 441
    - XRF complex, establishing
      - connections 442
  - contention, bracket 304, 457
  - control block 80
    - ISC 271
    - MFS 80
  - control character 88
  - control function, MFS
    - See* MFS (Message Format Service)
  - control region
    - execution parameters
      - defining in a shared-queues environment 106
  - controlling output 89, 92
  - conversation mode
    - errors
      - ISC 319, 321
    - explained 37
    - IMS-CICS 560
    - IMSpIex, in an 134
    - normal termination, ISC
      - extension 321
      - restriction 289
  - Conversational Abnormal Termination
    - exit routine 211
  - conversational processing 30
  - conversational processing in MSC
    - (multiple systems coupling) 216, 217
    - abend 217
    - planning for 215
    - remote destination verification 216
  - conversational transactions 30
    - in a shared-queues environment 100
  - coordinating performance information for MSC 233
  - coupling facility
    - defining CFRM policy
      - example 103
    - definition 12
  - CPI Communications application
    - program 395
      - abnormal termination 396
      - APSB call 395
      - ATBCMTP verb 396
      - Backout call 397
      - backout processing 396
      - Commit call 395
  - CPI Communications application
    - program (*continued*)
      - commit processing 395
      - DB2 UDB for z/OS plan name, use of 395
      - ESS Attach Facility 395
      - in-flight unit of recovery, definition 400
      - indoubt unit of recovery, definition 400
      - normal termination 396
      - programming requirements 398
      - pseudonym files 398
      - recovery 398
      - resolve-in-doubt processing 397
      - return codes 397
        - RR\_BACKED\_OUT 397
        - RR\_OK 397
        - RR\_PROGRAM\_STATE\_CHECK 397
      - RTT 395
      - session failure 397
      - SQL calls 395
      - SRRCMIT 395
      - system restart 397
      - two-phase commit process and 399
  - CPI-C (Common Programming Interface for Communications) 7
    - APPC/IMS 26
    - initialization 26
    - side information 26
    - transactions 29
  - CQS (Common Queue Server) 12
    - access with IMS commands 111
    - checkpoint data set 14
    - client
      - exit routines 15
    - client, definition 12
    - cold start 109
    - coupling facility
      - changing structure size 109
    - definitions 12
      - execution parameters 106
      - global structure parameters 106
      - initialization parameters 106
      - local structure parameters 106
    - list structures
      - planning 112
    - logging
      - OC/390 logger 110
    - overview 15
    - restarting 108
      - after system checkpoint 109
    - shared queue environment, in a 13
    - shutting down 110
    - starting 108
    - structures
      - checkpoint, initiating 109
      - copying 110
      - rebuilding 109
      - recovering 109, 110
    - system checkpoint 109
      - data sets 109
      - initiating 109
      - restart 109
    - user-supplied exit routines 109
    - using 108
    - warm start 108
  - CQS (Common Queue Server) (*continued*)
    - log token 108
  - cross-system queuing determination 234
  - CSBLK DSECT 130
  - CTC (channel-to-channel)
    - MSC (multiple systems coupling)
      - physical link type 197, 198
- ## D
- data descriptor FM header
    - IMS use 569
    - input format 382
    - output format 382
    - use on input 368
    - use on output 368
  - data flow 29
    - in an MSC (multiple systems coupling) network 200
    - message switching 32
    - program-to-output terminal 30
    - program-to-program 30
    - terminal-to-program 30
  - data flow control (DFC) protocols 319
    - bracket and half-duplex 330
    - bracketing messages
      - input 330
    - chaining 339
    - commands
      - BID 330
      - ERP PURGE 341
    - error handling 319
    - examples 579
    - exception response 320
    - half-session synchronization 321
    - input messages, backing out 322
    - paged message errors 346
    - PURGE after exception response 340
    - recoverability aided by LWA 321
    - response requirements 321
    - sense codes 353
    - symmetrical session shutdown 355
    - sync point and response 322
      - CICS-IMS 562
        - input 326
        - output 327
  - data flow reset, handling errors 351
  - data partitioning, MSC (multiple system coupling) 197
  - data stream profile, ATTACH FM header 376
  - data transmission
    - definite responses, ISC 263
    - error handling 490
    - error recovery procedure 570
    - exception responses, protocol
      - CICS-IMS 561, 570
      - Finance Communication System 440
      - ISC 263
    - messages
      - input 473
      - output 479
    - response requirements
      - IMS commands and indicators 264, 439
      - IMS message switches 327, 489



- data transmission (*continued*)
  - response requirements (*continued*)
    - irrecoverable-inquiry transactions 327, 489
    - LU 6.2 application program 67
    - MFS control requests 490
    - recoverable-inquiry transactions 327, 488
    - summary 486
    - VTAM commands and indicators 264, 439
  - SLU P, message data types 472
- data transparency 269
- data types, IMS advanced function network 472
- data-set-full condition 90
- database division 214
- DB2 UDB for z/OS
  - CPI-C
    - plan name, use of 395
- DBFHAGU0 (Input Edit/Routing exit routine) 20
- DCCTL (Data Communication Control) 10
- DCCTL (Data Communications Control)
  - generation 10
  - IMS BTS 10
  - procedures 10
  - TM batch 10
- deadlock 232
- DEADQ STATUS 182
- deblocking algorithm, ATTACH FM header 377
- deferred program switch 31
- defining
  - CICS 546
  - IMS 291
  - ISC node 291, 546
- definite responses
  - Finance Communication System 440
  - response requirements (figure) 486
  - SLU P 440
- demand-paged messages
  - controlling
    - QMODEL FM headers 369
- DEQUEUE command
  - committing ISC output messages 323
  - for MSC 232
  - FORCESS versus SYNCSESS 306
  - IMS-to-IMS ISC session 306
- dequeuing messages, implications 306
- deregistering interest
  - in transactions 97
  - shared queues
    - in LTERMs 98
    - in MSC (multiple systems coupling) resources 98
- descriptors
  - ETO
    - group logon, definition 143
    - generic ETO logon 142
    - logon
      - ETO 142
    - MFS device 143
    - MSC (multiple systems coupling) 143
    - specific logon, definition 143
  - descriptors (*continued*)
    - user 143
  - destination process name (DPN)
    - ATTACH FM header 378
    - message routing, ISC 280
    - SCHEDULER FM header 378
  - destination queue name, ATTACH FM header 381
  - destination system (MSC) 203
  - device class control 88
  - device input format (DIF) 80
  - device output format (DOF) 80
  - DFC (data flow control) protocols 319
    - bracket and half-duplex 330
    - bracketing messages 330
      - input 330
      - output 333
  - chaining 339
  - commands 330
    - BID 330
    - BIS 355
    - CANCEL 338
    - CHASE 339
    - LUSTATUS 343, 346
    - RSHUT 347
    - RTR 346
    - SBI 355
    - SIGNAL 355
  - ERP PURGE 341
  - error handling 319
    - conversation mode 320
    - response mode 319
    - selective receiver ERP 347
  - examples 579
  - exception response 320
  - half-session synchronization 321
  - input messages, backing out 322
  - paged message errors 346
  - PURGE after exception response 340
  - recoverability aided by LWA 321
  - response requirements 321
    - irrecoverable-inquiry transactions 321
    - recoverable-inquiry transactions 321
  - sense codes 353
  - symmetrical session shutdown 355
  - sync point and response 322
    - availability 322
    - CICS-IMS 562
  - exceptions for synchronous
    - input 322
    - input 326
    - irrecoverable messages 325
    - MFS output messages, ISC 324
    - output 327
    - recoverable messages 324
    - requested on input 322
    - requested on output 323
  - DFS3650 (session status message) 62
  - DFSAPPC message switching 428
  - DFSCCBK 130
  - DFSCMUX0 exit routine 223
  - DFSFEJ0 (Front-End Switch exit routine)
    - special support 255
- DFSINSX0 (Output Creation exit routine)
  - shared queues
    - dynamic control blocks 99
    - message switching 99
- DFSMSxxx control block 218
- DFSSIML0 exit routine 92
- DIF (device input format) 80
- direct-control subsystem 557
- directed routing 210, 226
  - MSC 210
    - password not passed across link 226
- disability xviii
- disabling enforcement
  - resource name uniqueness 18, 130
  - resource type consistency 19, 130
- display screen protection
  - BID option 453
  - definition 453
  - Finance Communication System terminals 453
  - MFS 453, 454
  - NOBID option 453
- Distributed Presentation Management (DPM) 87
  - FM headers 364
  - option 87
  - OPTIONS=DPAGE or PPAGE 364, 481
  - output 481
  - SLU P supports 450
- distributed transaction processing, ISC 255, 280
- documentation
  - exit routines 222
  - terminal profiles 59
- DOF (device output format) 80
- DPM (Distributed Presentation Management) 87
  - FM headers 364
  - option 87
  - OPTIONS=DPAGE or PPAGE 364, 481
  - output 481
  - SLU P supports 450
- DPN (destination process name)
  - ATTACH FM header 378
  - message routing, ISC 280
  - SCHEDULER FM header 378
- DR2 response
  - exception
    - Fast Path 460
    - irrecoverable-inquiry transactions 487
    - MFS output 486, 487
    - nonrecoverable output 447
    - when MOD does not specify PAGE=YES 470, 488
  - requirements
    - MFS paged output messages, not Fast Path 447
    - normal IMS output messages 447
    - recoverable-inquiry transaction 488
- DSCA operand, DEV statement 91
- duplicate databases 214
- dynamic allocation VTAM subpools 274
- dynamic terminals 8

## E

- EB (end bracket) indicator
  - definition 277
  - LUSTATUS command 343
  - use (figure) 443
  - used with ATTACH 272
- edit
  - basic edit during ISC 270
  - ISC
    - default editor 269
  - MFS
    - CICS 539
    - during ISC 270
  - options
    - data communication exit routine 270
    - input and output 269
    - ISC input and output, list 256
- editing facilities
  - invoking FM headers 358
  - ISC overview 269
- editing messages
  - basic edit and nongraphic messages 87
  - bypassing Basic or MFS editing 86
  - editing performed by IMS 84
  - output segments 86
  - transparency option 85
- editing options
  - COMPTn parameter of TERMINAL macro 296
  - MFS-SCS1 523
  - OUTBUF parameter of TERMINAL macro 295, 456
  - SLU P, COMPTn parameter of TERMINAL macro 455
  - types
    - DPM-An 455, 481
    - MFS-SCS1 455
    - SCS1 455
- EMH (expedited message handler)
  - queue option
  - overview 20
- EMH (Expedited Message Handler)
  - shared queues environment, in a 116
- EMH buffer 47
- EMHL control region initialization
  - parameter 48
- enabling
  - shared queues 103
- end bracket indicator
  - definition 277
  - LUSTATUS command 343
  - use (figure) 443
  - used with ATTACH 272
- ERP (error recovery procedure)
  - CICS-IMS session 570
  - extended 570
  - FM header 359
  - format 383
  - function management header 570
  - implemented by IMS 439
  - selective receiver
    - sense codes 347
- ERP PURGE, after ISC exception
  - response 340
- error handling 490
  - error handling (*continued*)
    - BREAK code X'0811' 492
    - CANCEL command 338
      - use 494
      - when sent by IMS 494
    - controller-detected errors
      - system sense field 491
      - use 491
      - user sense field 493
    - error messages 365
    - FM header 359
    - IMS-detected errors 491
    - IMS-issued error messages in XRF complex 491
  - ISC
    - CICS-IMS session 570
    - paging errors, during data flow
      - reset state 351
    - paging errors, for nonpaged messages 353
    - paging errors, for paged messages 346
    - selective receiver ERP 347
    - sender ERP 351
    - sender ERP sense codes 351
    - length of message 359
    - LUSTATUS command 344, 493
    - MFS-detected errors 365
    - queuing messages 359
    - RQR command 494
    - SIGNAL command 494
    - SLU P 490
    - VTAM logical unit status command 560
  - error messages
    - conditions causing
      - BB-only specified on input 478
      - BB-only specified on output 485
    - length 359, 491
    - MFS-detected errors 365
  - error recovery procedure (ERP)
    - CICS-IMS session 570
    - extended 570
    - FM header 359
    - format 383
    - function management header 570
    - implemented by IMS 439
    - selective receiver
      - sense codes 347
  - errors
    - ISC session termination, causing 351
  - establishing connection 265
  - ESTAE process
    - bypassing affinity management during 128
  - ETO (Extended Terminal Option) 8
    - /SIGN command for ETO STSN devices 192
    - 3275 devices 153
    - 3600/Finance 192
    - ABENDU0015 172
    - advantages 147
    - availability 147
    - LTERMs 147
    - algorithm 164, 178
    - logon descriptor 164
    - LTERM allocation 178
- ETO (Extended Terminal Option)
  - (*continued*)
    - associated printing techniques 179
    - asynchronous output 187
    - autologoff 184
    - autologon 186
    - autosignoff 183
    - benefits of using 139
    - commands that reset status and release control blocks 179
    - commands that retain status 179
    - common logon descriptors 161
    - conversations 31, 193
    - customizing 144, 148
    - dead-letter queue 187, 188
    - default CINIT/BIND user data formats 174
    - deleting control blocks 189
      - after logoff 189
      - after signoff 189
    - delivering output to non-originating terminal 188
    - descriptors
      - added 173
      - creating during system
        - definition 161
      - definition 142
      - deleted 173
      - generic logon, definition 142
      - group logon, definition 143
      - introduction to coding 160
      - logon 161
      - logon, definition 142
      - MFS 168
      - MFS device, definition 143
      - MSC (multiple systems coupling)
        - coupling) 171
      - MSC (multiple systems coupling), definition 143
      - specific logon, definition 143
      - updated 173
      - user 165
      - user, definition 143
      - using 144
      - VTAM TERMINAL macro 161
    - device characteristics table 154, 168
    - device type, defining 152
    - DFS2085 175
    - DFS3641W 172
    - DFS3645 175
    - DFS3649A 177
    - DFS3650 177
    - DFS3672 175
    - DFSINSX0 168
    - DFSSGNX0 168
    - DFSUSER descriptor 167
    - DLQT 188
    - dynamic terminal
      - definition 140
    - dynamic terminals 8
    - dynamic user, definition 140
    - exit routines
      - using 144
    - exit routines, coding 172
    - exit routines, list of 172
    - guideline selection 163
    - logon descriptors 163

ETO (Extended Terminal Option)  
*(continued)*  
 guideline selection *(continued)*  
 LOGOND parameter 163  
 initialization 172  
 descriptor validation 172  
 DFSINTX0 172  
 logon 161  
 /OPNDST command 173  
 descriptor format 161  
 INITOTHER 173  
 INITSELF 173  
 signon data 173  
 USS LOGON 173  
 LTERM with specific destination 177  
 LU 2  
 devices 153  
 screen size and model  
 information 154  
 LU 6.1 (ISC) terminals 190  
 MFS 158  
 MFS device characteristics table 154,  
 168  
 MFSDCT utility 154  
 MODETBL on ETO logon  
 descriptor 63  
 MSC (multiple systems  
 coupling) 160  
 descriptor 160  
 descriptor format 171  
 MSNAME macro 160  
 support 160  
 multiple signons 175  
 node user descriptor 167  
 non-SNA 3270 devices  
 printers and displays 153  
 screen size and model  
 information 154  
 NTO devices 154  
 overview 139  
 queue (dynamic user message),  
 definition 140  
 RACF 8  
 recommendations 167  
 requirements 148  
 response mode 193  
 screen definitions examples (non-SNA  
 3270) 156  
 display (model specified) 157  
 display (screen size specified) 157  
 LU0 video 156  
 model 2 printer 156  
 screen size control byte 154  
 security 157  
 number of profiles 47  
 RACF 158  
 Security Maintenance Utility  
 (SMU) 158  
 signon 157  
 shared printing 181  
 signing off, definition 189  
 signing on, definition 175  
 signon 158  
 ETO terminals 158  
 LTERM allocation 175  
 static terminals 158  
 SLU P 192

ETO (Extended Terminal Option)  
*(continued)*  
 SMU, nonsupport of 9  
 SNA commands 173  
 special processing modes 178  
 starting ETO 172  
 static terminal, definition 140  
 storing descriptors 161  
 structure  
 definition 140  
 terminal, definition 140  
 user, definition 140  
 structure, creation and deletion 143  
 STSN terminals 191  
 support for /SIGN command 192  
 system definition 161  
 terminal  
 definition 140  
 terminal-LTERM relationship 177  
 terminology 140  
 undeliverable data, dead-letter  
 queue 188  
 /DISPLAY STATUS USER  
 command 188  
 /DISPLAY USER DEADQ  
 command 188  
 user descriptors  
 DFSUSER 167  
 format 165  
 installation-created 165  
 node user descriptor 165, 167  
 VTAM CINIT LUNAME 163  
 VTAM considerations 152  
 logon CINIT session control  
 blocks 152  
 VTAM PSERVIC parameters 152  
 examples, ISC data flow control 579  
 exception response  
 DFC command, purging 319  
 ISC response mode errors 320  
 protocol  
 response requirements  
 (figure) 486  
 VTAM facilities 263  
 exclusive mode 38  
 execution mode  
 IMS-CICS communication 537  
 recovery at ISC session failure 308  
 specification, ISC 272, 274  
 supported by ISC, list 256  
 execution modes 537  
 EXIT command  
 ISC conversation mode errors 320  
 terminating a conversation  
 abnormally 37  
 exit routines  
 for ETO 172  
 for MSC 222  
 expedited message handler (EMH) 19  
 queue option  
 overview 20  
 extended output component  
 protection 453  
 Extended Recovery Facility (XRF) 26  
 Class 1 terminals 54  
 Class 2 terminals 52  
 Class 3 terminals 53

Extended Recovery Facility (XRF)  
*(continued)*  
 class of service 53  
 definition 49  
 establishing communication  
 Finance Communication  
 System 442  
 ISC 302  
 SLU P 442  
 system takeover  
 considerations 442  
 local queue manager data sets 100  
 master terminals 35  
 recovery modes 42  
 SLU P application program 438  
 takeover considerations  
 Finance Communication  
 System 442  
 SLU P 442  
 terminal support 26, 53  
 terminals in 50  
 Extended Terminal Option (ETO) 8  
 /SIGN command for ETO STSN  
 devices 192  
 3275 devices 153  
 3600/Finance 192  
 ABENDU0015 172  
 advantages  
 availability 147  
 LTERMs 147  
 algorithm  
 logon descriptor 164  
 LTERM allocation 178  
 associated printing techniques 179  
 asynchronous output 187  
 autologoff 184  
 autologon 186  
 autosignoff 183  
 benefits of using 139  
 coding descriptors  
 introduction 160  
 commands that reset status and  
 release control blocks 179  
 commands that retain status 179  
 common logon descriptors 161  
 conversations 31, 193  
 creating descriptors 161  
 customizing 144, 148  
 dead-letter queue 187, 188  
 default CINIT/BIND user data  
 formats 174  
 deleting control blocks  
 after logoff 189  
 after signoff 189  
 delivering output to non-originating  
 terminal 188  
 descriptors  
 added 173  
 definition 142  
 deleted 173  
 generic logon, definition 142  
 group logon, definition 143  
 logon 161  
 logon, definition 142  
 MFS 168  
 MFS device, definition 143

Extended Terminal Option (ETO)  
(*continued*)

- descriptors (*continued*)
  - MSC (multiple systems coupling) 171
  - MSC (multiple systems coupling), definition 143
  - specific logon, definition 143
  - updated 173
  - user 165
  - user, definition 143
  - using 144
- VTAM TERMINAL macro 161
- device characteristics table 154, 168
- device type, defining 152
- DFS2085 175
- DFS3641W 172
- DFS3645 175
- DFS3649A 177
- DFS3650 177
- DFS3672 175
- DFSINSX0 168
- DFSSGNX0 168
- DFSUSER descriptor 167
- DLQT 188
- dynamic terminal
  - definition 140
- dynamic terminals 8
- dynamic user, definition 140
- exit routines
  - using 144
- exit routines, coding 172
- exit routines, list of 172
- guideline selection
  - logon descriptors 163
  - LOGOND parameter 163
- initialization
  - descriptor validation 172
  - DFSINTX0 172
- logon
  - descriptor format 161
- LTERM with specific destination 177
- LU 2
  - devices 153
  - screen size and model information 154
- LU 6.1 (ISC) terminals 190
- MFS 158
- MFS device characteristics table 154, 168
  - screen size and model information 154
- MFSDCT utility 154
- MODETBL on ETO logon
  - descriptor 63
- MSC (multiple systems coupling)
  - descriptor 160
  - MSNAME macro 160
  - support 160
- multiple signons 175
- node user descriptor 167
- non-SNA 3270 devices
  - printers and displays 153
  - screen size and model information 154
- NTO devices 154
- overview 139

Extended Terminal Option (ETO)  
(*continued*)

- queue (dynamic user message), definition 140
- RACF 8
- recommendations 167
- reduction of time of system
  - definition 9
- requirements 148
- response mode 193
- screen definitions examples (non-SNA 3270) 156
- screen size control byte 154
- security
  - number of profiles 47
  - signon 157
- shared printing 181
- signing off, definition 189
- signing on, definition 175
- signon
  - ETO terminals 158
  - static terminals 158
- SLU P 192
- SMU, nonsupport of 9
- SNA commands 173
- special processing modes 178
- starting ETO 172
- static terminal, definition 140
- storing descriptors 161
- structure
  - definition 140
  - terminal, definition 140
  - user, definition 140
- structure, creation and deletion 143
- STSN terminals 191
  - support for /SIGN command 192
- system definition 161
- terminal
  - definition 140
- terminal-LTERM relationship 177
- terminology 140
- undeliverable data, dead-letter queue 188
- user descriptors
  - DFSUSER 167
  - format 165
  - installation-created 165
  - node user descriptor 165, 167
- VTAM CINIT LUNAME 163
- VTAM considerations
  - logon CINIT session control blocks 152
  - VTAM PSERVIC parameters 152
- external execution mode, ISC 272
- external subsystem, definition 9
- extracting multiple system transaction statistics 236

## F

facilities

- available on IMS-CICS session 535, 557
- component definition 445, 446
- display screen protection 453
- Finance Communication System 445
- ISC 269

facilities (*continued*)

- Message Format Service 450
- message recovery 451
- SLU P 445
- terminal-response mode 447
- test mode for ISC 271
- failure
  - CICS-IMS session 571
  - ISC, recovering from in-bracket 307
  - system, during CICS-IMS session 571
  - while in-brackets 305, 310
- Fast Path 8
  - EMH buffer size 47
  - Input Edit/Routing exit routine (DBFHAGU0) 20
  - input message 447
  - message queue list structures
    - defining 105
    - example 106
  - messages 8
  - MFS NEXTMSG or NEXTMSGP
    - control commands 447
  - MFS paged output messages 447
  - NFPACK option on Terminal macro 460, 461
  - output messages 447
  - overview 8
  - parameters
    - FORCERESP 459
    - FPACK/NFPACK 459
    - OPTACK 459
  - recoverable-inquiry transactions 67, 488
  - recovery 42
  - restrictions for applications 20
  - routing code 19
  - RTR command 460
  - TERMINAL macro
    - options 459
    - required parameters 459
  - terminal-response mode 447
  - terminals 47
  - transactions
    - recommendation 119
- Fast Path EMH
  - shared queues environment overview 20
- Finance Communication System
  - application program
    - converting Finance to SLU P 438
    - functions available 437
    - MFS considerations 437
  - bracket and send/receive protocols 443, 473
  - facilities 445
  - major parts 436
  - sample configuration 436
  - session parameters 503
  - system takeover considerations 442
  - terminals supported 436
  - VTAM
    - commands and indicators 439
    - facilities 439
  - workstations 436
  - XRF complex, establishing connections 442

- first speaker
  - ISC contention winner 266
  - secondary logical units 266
- flow
  - of data
    - in an MSC (multiple systems coupling) network 200
- FM (function management) header
  - error recovery procedure (ERP) format 383
- FM (function management) headers
  - coding for use with CICS 564
- Finance Communication System 475, 483
- IMS, data descriptor 569
- input FM header length 359
  - ATTACH FM header 359
  - output FM header 482
- input message 269
- input process names 381
- inserted by IMS 87
- ISC 356
  - ATTACH 358
  - ATTACH, MFS 367
  - data descriptor 368, 382
  - DPM messages, MFS 364
  - error recovery procedure 359, 570
  - header format 393
  - initiating a process 358
  - Input QMODEL FM Headers 370
  - introduction 356
  - invoking ISC edit 358
  - MFS 363, 372
  - QMODEL 369, 383
  - QMODEL, CICS 569
  - RAP 359
  - RAP, MFS 372
  - Reply QMODEL FM Headers 371
  - SCHEDULER 360, 567
  - SCHEDULER, MFS 367
  - synchronous processing 358
  - SYMSG 361
  - system message 361, 570
- message descriptor byte format 476
  - input 476, 477
  - output 482, 483
- MFS 569
- output message 272
- output process names 381
- processing mode requested 272
- security 257
- SLU P 476, 483, 484
- type X'42' (SLU P) 478
- FM headers
  - See* FM (function management) headers
- FMH
  - See* FM (function management) headers
- format, message
  - control characters in message
    - prefix 88
  - creating with SDF II 81
  - transparency option 85
- forms 90
- FPACK/NFPACK option, Fast Path 459

- front-end IMS
  - in a shared queues environment 96
- front-end subsystem
  - CICS
    - SEND LAST command 541
    - SEND/RECEIVE command 539
    - START/RETRIEVE command 544
  - function of 255
  - IMS 542, 545
- Front-End Switch exit routine (DFSFEJ0)
  - special support 255
- front-end switch planning 113
- function abort
  - detecting loop, ISC 348, 353
  - indicated on LUSTATUS command 344
- function management (FM) headers
  - coding for use with CICS 564
  - error recovery procedure (ERP) format 383
  - Finance Communication System 475, 483
  - IMS, data descriptor 569
  - input FM header length
    - ATTACH FM headers 359
  - input message 269
  - input process names 381
  - inserted by IMS 87
  - ISC 356
    - ATTACH 358
    - ATTACH, MFS 367
    - data descriptor 368, 382
    - DPM messages, MFS 364
    - error recovery procedure 359, 570
    - format reference 373
    - header format 393
    - initiating a process 358
    - Input QMODEL FM Headers 370
    - introduction 356
    - invoking ISC edit 358
    - MFS 363, 372
    - QMODEL 369, 383
    - QMODEL, CICS 569
    - RAP 359
    - RAP, MFS 372
    - Reply QMODEL FM Headers 371
    - SCHEDULER 360, 567
    - SCHEDULER, MFS 367
    - supported by IMS, summary 357
    - synchronous processing 358
    - SYMSG 361
    - system message 361, 570
  - message descriptor byte format 476
    - input 476, 477
    - output 482, 483
  - MFS 569
  - output message 272
  - output process names 381
  - processing mode requested 272
  - security 257
  - SLU P 476, 483, 484
  - type X'42' (SLU P) 478
- functions
  - ISC and CICS 259, 535
  - ISC versus MSC 254

## G

- generic resource groups 16
  - benefits 16
  - definition 16
  - overview 16
- generic resource member, definition 16
- generic resource name
  - definition 16
  - specifying 123
    - GRSNAME= startup parameter 123
    - VGRS parameter 123
- generic resources
  - affinities
    - IMS managed 122
  - APPLID name 124
  - MNPS name
    - initiating a session 123
  - planning for 121
  - restrictions on using 122
- global callable services 130
- GRAPHIC= parameter
  - NO option 87
  - SEG statement 87
- GRESTAE command 128
- GRSNAME=
  - specifying a generic resource name 123

## H

- half session
  - definition 300, 303
  - pairs 296, 303
  - synchronization, ISC 321
- half-duplex protocol, IMS use 330
- HANDLE CONDITION, CICS 555
- headers
  - input message
    - See* FM (function management) headers
  - ISC
    - See* FM (function management) headers
  - output message
    - See* FM (function management) headers
  - type X'42'
    - component identification 478
    - data bytes 484
    - message descriptor byte 477, 483
- HIOP (high input/output pool)
  - VTAM output buffers
    - RECASZ execution parameter 62
- horizontal partitioning in MSC (multiple systems coupling) 197

## I

- IDLE command 228
- immediate program switch 32
- immediate session termination
  - See* session termination
- IMS
  - dead-letter queue 116

- IMS message switches, response requirements 489
- IMS Monitor
  - MSC considerations 233
  - Report Print Program 234
- IMS transaction abend 575
- IMS-CICS communication
  - alternate facility 559
  - application coding for 556
  - asynchronous processing flow 543
  - ATTACH parameters 564
  - CICS transactions, definition 554
  - coding
    - function management headers 564
    - system definition options 546
  - facility
    - alternate 559
  - IMS commands 561
  - IMS-CICS ISC 554
  - initiating sessions 555
  - integrity of session 572
  - LU 6.1 links
    - compatible nodes 548
    - description 547
    - Macro-Level Resource Definition 547
    - multiple links 552
    - Resource Definition Online 547
  - MFS support 569
  - preparing CICS tables 547
  - principal facility 559
  - processing flows
    - RECEIVE 542
    - RETRIEVE 545
    - SEND INVITE 540
    - SEND LAST 541
    - SEND/RECEIVE 540
    - START/RETRIEVE 544
  - recovery and restart 570
  - SCHEDULER parameters 567
  - session
    - binding 572
    - initiation 555
    - processing outstanding traffic 573
    - reestablishing 572
    - resynchronizing 572
    - sync points 562
    - termination 556
  - sync points 562
  - terminating a session 556
  - transactions
    - attributes supported 537, 559
    - types supported 537, 559
- IMS-to-IMS communication, LU 6.1 protocols 288, 291
- IMS-to-IMS sessions, ISC protocol restrictions 290
- IMS.FORMAT, output from MFS 74
- IMS.PROCLIB 52, 218
- IMSCTRL macro, MSC system definition 218
- IMSIDs
  - when an IMSplex and MSC network coexist 244
- IMSMSV procedure 218
- IMSplex
  - affinity
    - in an MSC-IMSplex configuration 239
  - APPC and OTMA messages
    - processing MSC remote transactions 245
  - definition 12
  - IMSIDs
    - when an IMSplex and MSC network coexist 244
  - link definitions in an IMSplex
    - deleting 244
  - message routing
    - in an MSC-IMSplex configuration 238
  - MSC (Multiple Systems Coupling)
    - coexistence 237
    - migration 240
    - sharing MSNAME definitions and SYSIDs 240
  - MSC MSNAME definitions
    - duplication 243
    - sharing MSNAME definitions and SYSIDs 240
  - MSNAME definitions
    - deleting 244
  - pseudoabend U0830
    - avoiding 247
  - SYSIDs
    - cloning MSC SYSIDs in an IMSplex 244
    - managing MSC SYSIDs in an IMSplex 244
    - sharing MSNAME definitions and SYSIDs 240
  - TM resources
    - managing 129
- Information Management System (IMS)
  - See IMS
- initialization
  - IMSplex, in an 134
- initiation
  - session 66
- INOP state 39
- input bracketing
  - replies 478
  - rules 478
- input component
  - identification for header type X'42' 478
  - relationship to output component 274
  - versus output component 445
- input editing option
  - ISC 269
  - SLU P 455
- input errors, IMS detection of ISC 350
- input message
  - backing out ISC 322
  - bracketing 476, 478
  - chained messages 339, 479
  - Fast Path 459
  - Finance Communication System chaining indicator 475
  - header
    - DPM 477
- input message (*continued*)
  - header (*continued*)
    - Finance format 475
    - MID name location 475, 477
    - optional MFS (message format service) fields 477
    - SCS 477
    - SLU P format 476
    - use 475, 477
  - ISC bracketing 330
  - message descriptor byte
    - header type X'42' 477
    - MID name indicator bit 476, 477
  - MFS (message format service) input formatting, activating 478
  - MFS input formatting, activating 363
  - multiple transmissions for one message 479
  - origin of for MFS (message format service) purposes 479
  - requirements 475
  - response requirements 486
  - SLU P
    - chaining indicator 475
    - restriction 478
  - sync point
    - availability 322
    - ISC 322
- input message, response requirements 327
- input system (MSC) 203
- integrity
  - IMS-CICS session 572
  - message 572
  - IMS-CICS session 572
    - in ISC 257
    - NOCHECK PROTECT 544
- interchange unit code, ATTACH FM header 375
- interest
  - registering interest
    - concept 97
- intermediate IMS
  - MSC
    - security checking 226
- intermediate system (MSC) 203
- internal execution mode, ISC 273
- Intersystem Communication (ISC) 253
  - application program
    - accessing 278
    - example 593
  - binding an ISC session 302
  - CICS-IMS 535
  - control block storage, parallel sessions 271
  - conversation mode termination extension 321
  - DFC protocols 329
  - DFC sync point 322
    - exception 322
    - irrecoverable messages 325
    - MFS messages 324
    - on output 323
    - recoverable messages 324
  - editing facilities
    - invoking FM headers 358
    - overview 269

Intersystem Communication (ISC)  
(*continued*)

- editing options 84
- error handling
  - MTO notified 347
  - sender ERP 351
- error recovery, purge after exception response 340
- execution mode
  - external specification 272
- facilities 269, 276
- FM headers
  - CICS session 564
  - format reference 373
  - introduction 356
  - routing messages 280
  - supported by IMS 357
- half session, primary versus secondary 302
- IMS commands, issuing 270
- IMS support, CICS 535
- IMS-to-IMS session
  - design considerations 288
  - MSC and ISC coexistence 288
- introduction 253
- message integrity, CICS 571
- message resynchronization sessions 304
- message routing
  - FM headers 280
- MSC coexistence 288
- network operation 300, 301
- node definition
  - macros used 291
- output editing option 269
- output protocols 277
- parallel sessions issuing IMS commands 270
- protocols
  - restrictions on IMS-to-IMS sessions 290
- resynchronization procedure 305
- routing examples 281
- routing parameters 281
- SC protocols
  - session initiation 301
- sense codes
  - received 353
- statically defining 291
- test mode 271
- transaction types supported, CICS session 537, 559
- versus CICS 559
- VTAM facilities 263
- XRF complex 302

invalid destinations in MSC (multiple systems coupling) 211

IOBUF pool 69

irrecoverable messages, ISC sync points 325

irrecoverable transactions 290

irrecoverable-inquiry transactions
 

- LU 6.2 application program 67
- response requirements 67, 489

ISC (Intersystem Communication) 253

- application program 278, 593
- accessing 278, 280

ISC (Intersystem Communication)  
(*continued*)

- application program (*continued*)
  - example 593
  - not using MFS 279
  - using MFS (message format service) 279
- basic functions 253, 254
- binding an ISC session 302
- CICS and IMS functions 259
- CICS-IMS 535
- Class 2 terminal 257
- configurations 258, 259
- control block storage, parallel sessions 271
- conversation mode termination extension 321
- data flow control 253
- DFC protocols 329
  - availability 322
  - backing out input messages 322
  - BID command 330
  - bracket and half-duplex 330
  - bracketing input messages 330
  - bracketing output messages 333
  - CANCEL command 338
  - chaining 339
  - CHASE command 339
  - conversation mode errors 320
  - exception response 319
  - half-session synchronization 321
  - LUSTATUS 343
  - paged message errors 346
  - recoverability supplemented by LWA 321
  - response mode errors 319
  - response requirements 321
  - RSHUT command 347
  - RTR command 346
  - selective receiver ERP 347
  - sync point, input messages 322
- DFC sync point 322
  - exception 322
  - irrecoverable messages 325
  - MFS messages 324
  - on output 323
  - recoverable messages 324
- distributed processing 255
- distributed services, support for 256
- editing facilities
  - invoking FM headers 358
  - overview 269
- editing options 84
- error handling
  - MTO notified 347
  - sender ERP 351
- error recovery, purge after exception response 340
- execution mode 256, 272
  - external specification 272
  - internal definition 273
  - internal, with CICS 537
  - processing mode 273
  - synchronous versus asynchronous 273
- facilities 257, 269, 276
- FM headers 280, 356, 564

ISC (Intersystem Communication)  
(*continued*)

- ATTACH 358
- ATTACH, MFS 367
- CICS session 564
- data descriptor 368
- DPM messages, MFS 364
- error recovery procedure 359
- format reference 373
- header format 393
- initiating a process 358
- introduction 356
- invoking ISC edit 358
- MFS 363, 372
- QMODEL 369, 372
- RAP (reset attached process) 359
- RAP (reset attached process), MFS 372
- routing messages 280
- SCHEDULER 360
- SCHEDULER, MFS 367
- supported by IMS 357
- synchronous processing 358
- SYMSMSG 361
- half session, primary versus secondary 302
- IMS commands, issuing 270
- IMS facilities 255
- IMS support for 255
- IMS support, CICS 535
- IMS-to-CICS configuration 258
- IMS-to-IMS configuration 258
- IMS-to-IMS session 288
  - buffer sizes 289
  - defining parallel session 289
  - defining single session 289
  - dequeuing messages 306
  - design considerations 288, 291
  - limit of parallel sessions 289
  - MSC and ISC coexistence 288
  - protocol restrictions 290
  - remote control 289
  - restriction on conversation mode 289
  - routing to back-end IMS 290
- introduction 253, 261
- message integrity 257
- message integrity, CICS 571
- message resynchronization 304
  - sessions 304, 312
  - summary 328
- message routing 280
  - FM headers 280
  - parameters 280, 281
  - through MSC links 288
- MSC coexistence 288
- network operation 300, 301
- node definition 291
  - COMM macro 293
  - example 291
  - macros used 291
  - NAME macro 294
  - SUBPOOL macro 294
  - summary 296
  - TERMINAL macro 295
- output editing option 269
- output protocols 277

ISC (Intersystem Communication)  
*(continued)*  
 parallel sessions issuing IMS  
 commands 270  
 passing CICS data to IMS 261  
 protocols 253  
   defined 299  
   restrictions on IMS-to-IMS  
   sessions 290  
   summary 253, 254  
 resynchronization procedure 305  
   cold start, to recover sessions 306  
   commands, recovery at  
   failure 308  
   controlling backout of work  
   unit 306  
   execution mode, recovery at  
   failure 308  
   maintaining sequence  
   numbers 305  
   output available at restart 307  
   recovering from in-bracket  
   failure 307  
   restart process 309  
   session failure, IMS failure 308  
   session failure, IMS still  
   running 308  
 routing 254  
 routing examples 281  
 routing parameters 281  
 SC protocols 301  
   binding sessions 302  
   cold start recovery 306  
   commands, recovery at  
   failure 308  
   controlling pending work  
   units 306  
   designing restart procedures 305  
   execution mode, recovery at  
   failure 308  
   maintaining sequence  
   numbers 305  
   output available at restart 307  
   recovering from in-bracket  
   failure 307  
   resolving bind race 304  
   restart process 309  
   session failure, IMS failure 308  
   session failure, IMS still  
   running 308  
   session initiation 301  
   session states 311  
   session termination 313, 351  
   XRF, session initiation 302  
 security 257  
 sense codes 353  
   received 353  
   sent 354  
 session control 253  
 statically defining 291  
 test mode 271  
 transaction types supported, CICS  
   session 537, 559  
 versus CICS 559  
 VTAM API 265  
   CICS 536  
   IMS 265

ISC (Intersystem Communication)  
*(continued)*  
 VTAM facilities 263  
 XRF complex 257, 302  
 ISC edit  
   default editor 269  
 ISC edit, non-MFS programs 279  
 ISC-CICS installation options 546

## K

keywords  
   *See* commands, keywords, macro  
   keywords

## L

libraries, online change 81  
 link  
   MSC (multiple systems coupling),  
   in 197  
   priorities, setting 220  
   queuing time assessments 236  
   security in MSC 226  
 link paths  
   MSC (multiple systems coupling)  
   logical 199  
 Link-Receive Routing exit routine in  
 MSC 249  
 links  
   deleting MSC link definitions in an  
   IMSplex 244  
   MSC (multiple systems coupling)  
   logical 198  
   physical 197  
   MSC (Multiple Systems Coupling)  
   definitions in an IMSplex 240  
 list structure  
   definition 14  
   overflow, definition 14  
   primary, definition 14  
 local processing  
   defined 96  
 local system  
   MSC (multiple systems coupling)  
   defined 200  
 lock mode 38  
 LOCK state 67  
 locked messages  
   on a shared queue 98  
 Log Analysis report 237  
   ID column for MSC entries 237  
   MSC transactions 237  
 Log Merge utility 236  
   log output, control of 236  
   MSC logs 236  
 log stream  
   z/OS  
   defining 106  
 Log Transaction Analysis utility, MSC  
   statistics 236  
 log write-ahead (LWA) 257  
 logging off 11  
 logging off, definition 11  
 logging on, definition 11  
 logging, MSC 233

logical destinations  
   MSC (multiple systems  
   coupling) 202  
 logical link path 231  
   commands for controlling 231  
 logical link paths  
   MSC (multiple systems  
   coupling) 199  
 logical links  
   MSC (multiple systems  
   coupling) 198  
 logical network design 32  
 logical page advance function (NEXTLP),  
 MFS 452  
 logical page requests function  
 (PAGE=nn), MFS 452  
 logical terminal (LTERM)  
   as a TM resource in a sysplex 131  
   chains 33  
   component definition 376  
   convention for naming 274  
   eliminating the need for 446  
   definition 26  
   definition to RM 131  
   ETO 8  
   master terminal 35  
   method for naming 445  
   MSC and 249  
   name uniqueness 129, 131  
   network design 32  
   queues 33  
   relationship to physical terminals 32  
   remote 208  
   resource type consistency 130  
   security  
     LTERM security for  
     commands 46  
     LTERM security for  
     transactions 45  
   separating input and output  
   devices 34  
   shared queues  
     when IMS registers interest 98  
   subpools, users and components 274  
 logical unit  
   definition 4  
   programmable, definition 6  
 logical unit of work 570  
 logical unit status command  
   *See* LUSTATUS command  
 logon descriptor  
   ETO  
   definition 142  
   generic 142  
   group, definition 143  
   specific, definition 143  
 logon mode  
   default logon mode table 265  
   session initiation 441  
 LOGON MODE table 63  
 lost messages in MSC 227  
 LTERM (logical terminal)  
   as a TM resource in a sysplex 131  
   chains 33  
   component definition 376  
   convention for naming 274  
   eliminating the need for 446



LTERM (logical terminal) (*continued*)  
 definition 26  
 definition to RM 131  
 ETO 8  
 master terminal 35  
 method for naming 445  
 name uniqueness 129, 131  
 network design 32  
 queues 33  
 relationship to physical terminals 32  
 remote 208, 249  
 resource type consistency 130  
 security  
   LTERM security for  
     commands 46  
     LTERM security for  
       transactions 45  
 separating input and output  
   devices 34  
 shared queues  
   when IMS registers interest 98  
 subpools, users and components 274  
 LTERM security  
   network security options  
     commands 46  
     transactions 45  
 LU 6.2  
   descriptors 26  
 LUSTATUS command 343  
   CICS 539, 560  
   commit 345  
   conversation mode  
     requesting normal  
       termination 321  
     sending errors 320  
   function abort 344  
   NO-OP 345  
   paging errors 346  
   protocol 343  
   queue empty 344  
   response mode errors 320  
   SLU P system 493  
   terminating test mode 271  
 LWA (log write-ahead) 321

## M

macro keywords 61  
 APPLID on COMM macro 60  
 COMM on BUFPOOLS macro 61  
 MODETBL on ETO logon  
   descriptor 63  
 MODETBL on TERMINAL macro 63  
 PASSWD on COMM macro 60  
 RECANY on COMM macro 61  
 maintenance 79  
 making CICS ready 555  
 making IMS ready 300, 463  
 master terminal 64  
   device choice 35  
   logon requirements 64  
   MSC routing 249  
   reserving an LTERM 26  
   XRF complex 35  
 master terminal operator (MTO)  
   *See* MTO (master terminal operator)

master-slave MSC (multiple systems  
 coupling) relationship 198  
 memory-to-memory (MTM)  
   MSC (multiple systems coupling)  
     physical link type 198  
 merging logs for MSC 236  
 message  
   bypassing MFS editing 86  
   control characters 88  
   editing of output segments 87  
   editing performed by IMS 84  
   flow  
     in a shared queues  
       environment 98  
   formatting and editing 81  
   IMS handling 12  
   in-flight  
     device LUs 65  
     program LUs 65  
   locked on shared queue  
     concept 98  
   MTO 100  
   output segment editing 86  
   scheduling  
     definition 29  
     Fast Path 19  
   sensitivity to nongraphic message  
     data 86  
     Z2 field 88  
 message advance function  
   (NEXTMSG) 452  
 message advance protect function  
   (NEXTMSGP) 452  
 message buffering with a Fast  
   Path-capable system 20  
 message contention 304, 457  
 Message Control/Error exit routine  
   (DFSCMUX0) 223, 232  
 message descriptor byte  
   input FM header 476, 477  
   output message 482, 483  
 message format service (MFS)  
   DPM 481  
 Message Format Service (MFS) 73  
   administration 78  
   advantages 79  
   application programs, accessing with  
     ISC 279  
   Bid options 452  
   bypassing MFS 86  
   bypassing with ISC application  
     programs 279  
   components, overview 81  
   control functions  
     Finance Communication  
       System 451  
     NEXTLP 452  
     NEXTTP 452  
     PAGE=nn 452  
   control requests, response  
     requirements 490  
   data bytes output message 484  
   default format 392  
   defining 450  
   delete characters 87  
   description 9  
   DPM option 87

Message Format Service (MFS)  
 (*continued*)  
 edit of ISC messages 270  
 editing 86  
 escape characters, not supported in  
   ISC 363  
 facilities available 450  
 FM header  
   activating output formatting 364  
 FM headers  
   activating input formatting 363  
   editing 363  
   facilities available 363  
   types 363  
 format errors not detected 363  
 formatting 464  
   activating input 464  
 input formatting 363  
 input messages 74  
 input segments 87  
 introduction 73  
 invalid paging request 454, 457  
 Language utility 74, 81  
 libraries, online change 81  
 message editor 81  
 message recovery 451  
 MID/MOD chaining 450  
 MSC (multiple systems  
 coupling) 217  
 online error detection 365  
 online performance 80  
 output formatting 451, 485  
   MOD name 485  
   typical application program  
     procedure 485  
 output formatting, ISC 364  
 output messages  
   editing segments 86  
   how MFS defines 74  
 overview 73  
 page delete function, not supported in  
   ISC 365  
 paging, CICS 537, 559  
 pool manager 81  
 Service utility 81  
 SLU P  
   benefits 451  
   station-by-station, availability 451  
 sync point, ISC messages 324  
 terminal keyboard lock and  
   unlock 86  
 message handling 12  
 message headers  
   *See* FM (function management)  
   headers  
 message input descriptor (MID) 81  
 message integrity 257  
 message output descriptor (MOD)  
   *See* MOD  
 message queue  
   deleting 110  
 message queue list structures  
   defining  
     Fast Path 105  
   defining in a shared-queues  
     environment 105  
 message queue, definition 19

- message recovery
  - Finance Communication System 457
  - message resynchronization 328, 458
  - MFS 451
  - MSC 232
  - restriction 458
  - SLU P system 457
- message resynchronization 304
  - associated system definition
    - options 305
  - CICS-IMS session 572
  - description 305, 572
  - design considerations 305, 465
  - direction and bracket indicators 473
  - effects on normal data
    - transmission 458, 465
  - Fast Path 461
  - how and when initiated 304, 458
  - last inbound/outbound 458
  - options for message sequence
    - numbers 465
  - performing 572
  - polarity of half-session pairs 305
  - purpose 304
  - requirements 304, 458
  - send/receive and bracket
    - protocol 473
  - sequence numbers 306, 466
  - STSN
    - flow, primary-to-secondary 314
    - flow, secondary-to-primary 315
    - format 317, 466
    - use of 310
- message routing
  - examples 281
  - in an MSC (multiple systems
    - coupling) network 201
  - in ISC
    - across an MSC link 288
    - use of routing parameters 281
- message switch
  - ATTACH FM header 373
  - examples 282
  - ISC 280, 281
- message switch, ISC 270
- message switches, response
  - requirements 327
- message switching
  - shared queues
    - Output Creation exit routine (DFSINSX0) 99
  - undefined destination
    - Output Creation exit routine 99
- message switching, DFSAPPC 428
- messages
  - routing
    - in an MSC-IMSplex
      - configuration 238
- MFS (Message Format Service) 73
  - administration 78
  - advantages 79
  - application programs, accessing with
    - ISC 279
  - Bid options 452
  - bypassing MFS 86
  - bypassing with ISC application
    - programs 279
- MFS (Message Format Service)
  - (continued)
    - components, overview 81
    - control functions 451
      - Finance Communication
        - System 451
      - NEXTLP 452
      - NEXTMSG 452
      - NEXTMSGP 452
      - NEXTPP 452
      - PAGE=nn 452
      - SLU P 452
    - control requests, response
      - requirements 490
    - data bytes output message 484
    - default format 392
    - defining 450
    - delete characters 87
    - description 9
    - DPM 481
    - DPM option 87
    - edit of ISC messages 270
    - editing 86
    - escape characters, not supported in
      - ISC 363
    - facilities available 450
    - FM headers 363
      - activating input formatting 363
      - activating output formatting 364
      - ATTACH 367
      - data descriptor 368
      - DPM messages 364
      - editing 363
      - facilities available 363
      - MOD name 364
      - QGET 370
      - QGETN 370
      - QMODEL 369, 372, 569
      - QPURGE 371
      - QSTATUS 372
      - QXFR 371
      - RAP (reset attached process),
        - MFS 372
      - SCHEDULER 367
      - specifying MID name 364
      - types 363, 372
    - format errors not detected 363
    - formatting 464
      - activating input 464
      - activating output 479
    - input formatting 363
    - input messages 74
    - input segments 87
    - introduction 73
    - invalid paging request 454, 457
    - Language utility 74, 81
    - libraries, online change 81
    - message editor 81
    - message recovery 451
    - MID/MOD chaining 450
    - MSC (multiple systems
      - coupling) 217
    - online error detection 365
    - online performance 80
    - output formatting 451, 485
      - MOD name 485
- MFS (Message Format Service)
  - (continued)
    - output formatting (continued)
      - typical application program
        - procedure 485
    - output formatting, ISC 364
    - output messages
      - editing segments 86
      - how MFS defines 74
    - overview 73
    - page delete function, not supported in
      - ISC 365
    - paging, CICS 537, 559
    - pool manager 81
    - Service utility 81
    - SLU P 451
      - benefits 451
      - station-by-station, availability 451
    - sync point, ISC messages 324
    - terminal keyboard lock and
      - unlock 86
  - MFS bypass option effect 74
  - MFS device characteristics table
    - entries 23
    - how used 154
    - use with non-SNA 3270 devices 155
  - MFS device descriptor, definition 143
  - MFS Distributed Presentation
    - Management (DPM)
      - See DPM
  - MFS Service utility 77
  - MFSTEST procedure 81
  - MID (message input descriptor) 81
  - MID/MOD chaining 451
  - migration
    - IMSplex from MSC 240
    - MSC to IMSplex 240
  - mirror transaction, CICS 543
  - MNPS name
    - in a generic resources
      - environment 123
  - MOD (message output descriptor)
    - name specification 364, 485
    - purpose 80
  - modes, terminal
    - conversation 37
    - ETO and exclusive mode 38
    - exclusive 38
    - lock 38
    - LU 6.2 36
    - response 36
    - SNA QUIESCE 39
    - test mode 38
  - MODETBL= keyword
    - overriding the defaults 266
    - specifying a default LOGON MODE
      - identifier 63
    - use during ISC logon 266
  - modified application program
    - LU 6.2 descriptor 418
    - remote execution, MSC 410
  - monitoring and tuning, MSC 233
  - MSASSIGN command
    - MSC (multiple systems coupling)
      - linking 199
    - MSC considerations 228
    - usage considerations 228

- MSC
    - LU 6.2 application transactions buffer size 219
  - MSC (multiple systems coupling)
    - administration
      - APPC 213
    - asynchronous LU 6.2 transactions 215
    - concepts 197
    - data flow 200
    - data partitioning 197
    - defining priorities 220
    - definition 197
    - definition of transaction codes 217
    - descriptor 143
    - design considerations 213
    - destination system 203
    - directed routing, program-to-program switch 211
    - input system 203
    - intermediate system 203
    - introduction 197
    - links
      - logical 198
      - physical 197
    - local system
      - defined 200
    - logical destinations 202
    - logical link paths 199
    - logical links, SDLC link 198
    - message routing 201
    - minimizing resource consumption 214
    - MSC conversation failure 217
    - non-VTAM links buffer size 219
    - overview 9
    - remote processing
      - defined 96
    - remote system
      - defined 200
    - routing path 201
    - serial transaction processing 221
    - shared queues
      - when IMS registers interest 98
    - shared-queues environment, in a 117
    - SYSID (system identifier) 204
    - system definition 217
    - system identifier (SYSID) 204
    - VTAM links buffer size 219
  - MSC (Multiple Systems Coupling) 420
    - /DEQUEUE command 232
    - affinity
      - in an MSC-IMSplex configuration 239
    - APPC and OTMA messages
      - remote processing 245
    - coexistence with ISC 288
    - comparison to ISC 254
    - dequeuing messages, responses, and transactions 232
    - functions compared to ISC 254
    - IMSIDs
      - in an IMSplex 244
    - IMSplex
      - sharing MSNAME definitions and SYSIDs 240
  - MSC (Multiple Systems Coupling) (continued)
    - IMSplex with shared queues coexistence 237
    - initializing 227
    - ISC facility 254
    - link definitions
      - in an IMSplex 240
    - link definitions in an IMSplex
      - deleting 244
    - logical links
      - deleting from an IMSplex 244
    - message routing
      - in an MSC-IMSplex configuration 238
    - migration to IMSplex 240
    - monitoring and tuning 233
    - MSNAME definitions
      - sharing in an IMSplex 240
    - MSNAME definitions in an IMSplex
      - deleting 244
    - MSNAME duplication in an IMSplex
      - with shared queues 243
    - operating procedures 227
    - performance 233
    - physical links
      - deleting from an IMSplex 244
    - pseudoabend U0830
      - avoiding 247
    - Queuing Summary Report 234
    - recoverable versus irrecoverable transactions 420
    - recovering transactions in APPC 420
    - recovery considerations 232
    - security checking
      - intermediate IMS 226
    - security considerations 225
    - shared queues
      - MSNAME duplication 243
      - sharing MSNAME definitions and SYSIDs 240
    - standard application programs 408
    - support for APPC/IMS 419
    - SYSID tables
      - deleting MSNAME definitions in an IMSplex 244
    - SYSIDs
      - cloning in an IMSplex 244
      - managing in an IMSplex 244
      - sharing in an IMSplex 240
    - Traffic Report 234
      - utility for verifying names 224
  - MSC Program Routing exit routine 249
  - MSGQ primary list structure 105
  - MSLINK definitions
    - deleting from an IMSplex 244
  - MSLINK macro, logical links 219
  - MSNAME
    - as a TM resource in a sysplex 132
    - RM definition 132
  - MSNAME definitions
    - deleting from an IMSplex 244
    - in a shared queues group duplication 243
    - sharing among systems in an IMSplex 240
  - MSNAME macro
    - logical link paths 199
    - logical path name 220
  - MSC (multiple systems coupling)
    - Directed Routing 210
    - reports 234
      - for MSC 234
      - MSC Queuing Summary 236
      - MSC Summaries 235
      - MSC Traffic 234
    - SYSID keyword 220
  - MSPLINK definitions
    - deleting from an IMSplex 244
  - MSPLINK macro, MSC partner
    - definition 219
  - MTM (memory-to-memory)
    - MSC (multiple systems coupling) physical link type 198
  - MTO (master terminal operator) 64
    - /OPNDST command 63
    - /RSTART LINK command 227
  - assignment of logical link 197
  - ISC errors 347
  - messages 100
  - MSC and master terminal operators 228
  - notification of session rejection 312
  - restarting the terminal 85
  - termination of transmission 227
- MULT1 parameter 278, 334
- MULT2 parameter 278, 334
- multichain input message switches
  - restriction 375
- multiple signons 62
  - description 175
  - naming conventions for 175
  - sysplex environment, in 176
- multiple systems 213
- Multiple Systems Coupling (MSC)
  - security considerations 225
- Multiple Systems Verification utility (DFSUMSV0) 210
- Multiple Systems Verification utility, using 224
- multisystem communication
  - initialization 227
  - termination 227

## N

- NAME macro 294
  - defining an ISC session 294
  - for remote logical terminals 199
- MSNAME macro 223
  - used to relate components 275
- name type 130
- name uniqueness
  - resource
    - disabling enforcement 130
  - name uniqueness, resource
    - disabling enforcement 18
- naming conventions 78
- NCP (Network Control Program) 6
- NCP (Network Control Programs) 5
- negotiable bind 303
- network 3
  - administration 23

- network (*continued*)
  - activities 23
  - APPC/IMS, operating with 11
  - communications 3
  - definition 60, 223
  - design considerations 23
  - documenting requirements 24
  - logical terminal network design 32
  - multiple systems, effect of 223
  - nonswitched communications network 34
  - operating
    - establishing communication 10
    - Finance Communication System 65, 436, 463, 472
    - IMS-CICS 555, 556
    - ISC 300, 301
  - operations, preparing for 59
  - optional components 3
  - planning 23
  - restarting after remote takeover 68
  - shutting down 300, 471
  - starting
    - Finance Communication System 65, 463, 464
  - terminating
    - Finance Communication System 470, 472
  - VTAM and NCP parameters 60
- network role 5, 7
- network security options
  - LTERM security
    - commands 46
    - transactions 45
- network-qualified LU name 427
- network, communications
  - See* communications network
- networking 213
- NO-OP indicated on LUSTATUS
  - command 345
- node definition, ISC 291, 297
- node name
  - See also* VTAM, node uniqueness 132
- node user descriptor 167
- nongraphic message data 86
- nonnegotiable bind 303
- nonswitched communications network 34
- NOSCAN option 481
- NRESTART command 90
- null output message
  - purpose 479
  - when not sent 450
  - when sent 485

## O

- online change
  - DISPLAY MODIFY command 68
  - libraries 81
  - Online Change utility 81
- online performance 80
- operator logical paging
  - paged messages 369, 371
  - paging errors 366
  - QXFR FM header 389

- operator logical paging (*continued*)
  - SLU P, MFS option 452
  - sync points 324
  - VTAM indicators 335, 338
  - when in effect 329
- OPNDST command
  - logging on 173
  - relation to MODETBL keyword 63
  - results of using 182
- OPTACK option
  - Fast Path 459
  - Finance Communication System 489
  - SLU P 456, 487
- options, CICS
  - system definition 546
  - table preparation 547
- OPTIONS= DPAGE or PPAGE
  - MFS DPM 364, 481
  - output message 389
- orderly session termination
  - CICS 556
  - ISC 313
  - VTAM 470
- OTMA (open transaction manager access)
  - shared-queues environment 115
    - asynchronous messages 115
    - synchronous messages 115
- OTMA (Open Transaction Manager Access)
  - MSC (Multiple Systems Coupling)
    - processing remote transactions in an IMSplex 245
- output
  - available at ISC restart 307
  - controlling 89, 92
  - MFS DPM 481
- output algorithms
  - RU chain 377
  - VLVB 377
- output bracketing 485
- output component
  - defining 278
  - relationship to input component 273
  - selection
    - identification number 275, 446
    - modifying 274, 446
    - system messages 361, 446
- output component ID byte, output message 482
- output component protection, extended 453
- Output Creation exit routine (DFSINSX0)
  - shared queues
    - dynamic control blocks 99
    - message switching 99
  - undefined transactions
    - dynamic control blocks 99
- output devices, control characters by type 88
- output editing option, SLU P 455
- output errors, MFS online detection 365
- output function management headers, ISC 564
- output message
  - between brackets
    - design considerations 450
    - figure 449

- output message (*continued*)
  - between brackets (*continued*)
    - how handled 449
    - ISC 310
    - message switching 489
  - description 479
  - Fast Path
    - Finance systems 459
    - SLU P systems 460
  - Finance Communication System
    - multiple transmission 479
    - read type field (SMSCRT) 480
    - read-flags field (SMSCRF/SMSCRE) 480
  - formatting, activating MFS 364, 485
  - ISC bracketing 333
  - MFS DPM 364
  - null
    - purpose 479
    - when sent 485
  - output bracketing 485
  - output FM header
    - Finance format 482
    - ID byte 482
    - message descriptor byte (Finance) 482
    - message descriptor byte (SLU P) 483
    - MFS data bytes (Finance) 482
    - MFS data bytes (SLU P) 484
    - response requests 486
    - SLU P format 483
  - segmenting 479
  - SLU P system
    - multiple transmission 479
    - read type field (SMSCRT) 480
  - sync point requested, ISC 323
  - temporarily stopping 470
  - types 479
    - when committed 323
  - output protocols, determining 277
  - output response requested by message type 487
  - OUTPUT= parameter, not used in ISC 294
  - overload avoidance, MSC 214

## P

- page advance function (NEXTTPP), MFS 452
- page delete function, MFS 365
- page protection state 39
- paging errors
  - ISC 346
  - online detection, MFS 366
- parallel sessions
  - bind requirements 303
  - ISC, defining IMS-to-IMS sessions 289
  - users permitted 274
- parameters
  - IMS control region execution parameters
    - defining 106
- partitioned configuration
  - shared queues 102

- partitioning
  - a shared-queues configuration 102
- partner systems in MSC (multiple systems coupling) linking 198
- PCB (program communication block)
  - alternate PCB 275
  - for an LTERM not in I/O PCB 446
  - I/O PCB 275
- Persistent Session Tracking
  - Termination of 56
- physical link
  - CTC type 219
  - failure 229
- physical links
  - MSC (multiple systems coupling) 197
- physical terminals
  - defining 149
  - device class control 88
  - separating input and output devices 34
- pool manager 81
  - MFS description 81
  - MFSTEST 81
- primary error recovery procedure 439
- primary resource name (PRN)
  - See PRN
- printed output
  - /ASSIGN command 89
  - 3270 printer components 90
  - 3270R and ETO 91
  - candidate printers 91
  - controlling 89, 91
  - operational considerations 91
  - printer component 90
  - shared printers 92
  - spooled output control 90
  - VTAMLIST definitions 90
- printers
  - associated 113
  - candidate 91
  - sharing 92
- PRN (primary resource name)
  - ATTACH FM header 379
  - message routing, ISC 280
  - SCHEDULER FM header 379
- processing affinity
  - in an MSC-IMSplex
    - configuration 239
- processor utilization, MSC 214
- program communication block (PCB)
  - See PCB (program communication block)
- program-to-program switch 216
  - conversational transactions 210
  - destination name 206
  - nonconversational transactions 210, 211
  - remote destination verification 216
- programmed symbols (PS)
  - administering 499
  - definition 499
  - designing applications 501
  - determining if loaded 499
  - example of loading 500
  - how to load 499, 501
  - solving load problems 500

- protected resource, definition 399
- protection
  - display screen 453
  - extended output component 453
- protocol
  - output 277
  - restrictions on IMS-to-IMS sessions 290
- PS (programmed symbols)
  - administering 499
  - definition 499
  - designing applications 501
  - determining if loaded 499
  - example of loading 500
  - how to load 499, 501
  - solving load problems 500
- pseudoabend U0830
  - avoiding 247
- PSTOP LINK command 227
- PSTOP state 67
- PURGE
  - error recovery procedure 340
    - begins 340
    - DFC protocol 341
    - DFC support layer 340
    - ends 340
    - multichain 340
    - single 340
    - spanning chains 340
    - state after selective receiver purge 342
    - state after sender purge 341
    - sender ERP 351
  - PURGE state 67

## Q

- QCF (Queue Control Facility)
  - cold queues
    - recovering 110
  - structures
    - recovering 110
- QEC command 470
- QERROR state 38
- QGET FM header
  - description 370
  - format 384
- QGETN FM header
  - description 370
  - format 385
- QLOCK state 38
- QMODEL FM headers
  - CICS 569
  - formats 383, 390
  - QGET 370
  - QGETN 370
  - QPURGE 371
  - QSTATUS 372
  - QXFR 371
  - reply or output 371
  - request or input 370
  - supported by IMS 369
- QPURGE FM header
  - format 386
  - received by IMS 371
- QSTATUS FM header
  - format 387

- QSTATUS FM header (*continued*)
  - sent by IMS 372
- QSTOP state 67
- qualifying an LU name 427
- Quality Control Facility (QCF)
  - cold queues
    - recovering 110
  - structures
    - monitoring 110
    - recovering 110
- Queue Control Facility (QCF)
  - structures
    - monitoring 110
- queue empty indication 344
- Queue Manager
  - in XRF environment 100
  - planning for 99
- queue rotation 335
- queue types
  - in a shared queues environment 97
- queued subsystem 557
- queues
  - balancing group 19
  - logical terminals 33
  - shared
    - See shared queues
- quiesce-at-end-of-chain command, VTAM 470
- QXFR FM header
  - as output 371
  - format 387

## R

- race, BIND 304
- RACF (Resource Access Control Facility)
  - APPC transaction security 431
  - ETO security 8, 158
  - security for MSC (Multiple Systems Coupling) 225
  - unauthorized terminal use 44
- RAP FM header
  - description 359
  - example 360
  - format 390
  - MFS 372
- Rapid Network Reconnect
  - and IMS Shutdown 56
  - Changing Levels of Support 55
  - defining level of persistent support for VTAM 70
  - defining level RNR support for VTAM 70
  - Defining VTAM for 70
  - Persistent Session Tracking 55
  - Signon Security 57
  - Specifying Levels of Support 54
  - Terminal Reconnect Protocols 57
  - using with XRF or VGR 56
- RCVYCONV= 41
- RCVYFP= 42
- RCVYSTSN= 41
- RDPN (Return Destination Process Name)
  - ATTACH FM header 380
  - message routing, ISC 280
  - SCHEDULER FM header 380

read flags field, output messages 480  
 read type field, output messages 480  
 ready-to-receive (RTR) command  
   *See* RTR (ready-to-receive) command  
 reassigning links in MSC 228  
 receive-any buffers 62  
 recoverable input, acknowledging 456  
 recoverable message sent, sequence numbers 465  
 recoverable messages, ISC sync points 324  
 recoverable versus irrecoverable messages 486, 489  
 recoverable versus irrecoverable transactions 420  
 recoverable-inquiry transactions, response requirements  
   IMS 486, 488  
   ISC 323, 326  
 recovering transactions in APPC 420  
 recovery  
   Fast Path 42  
   resource status 39  
 recovery considerations for MSC 232  
 recovery environment  
   distributed resources, definition 400  
   local resources, definition 400  
 recovery procedures 52  
 registering interest  
   in a shared queue  
     concept 97  
   in transactions 97  
   shared queues  
     in LTERMs 98  
     in MSC (multiple systems coupling) resources 98  
 RELQ command 470  
 remote control of IMS 289  
 remote destination name 206  
 remote destination verification  
   MSC (multiple systems coupling) conversations 216  
   system integrity 211  
 remote LTERMs 208  
 remote processing  
   MSC (multiple systems coupling) 96  
   shared queues 97  
 Remote Site Recovery (RSR)  
   protected conversations and 403  
   shared queues, planning for 118  
 remote system  
   MSC (multiple systems coupling) defined 200  
 remote takeover  
   determining message loss after 68  
   restarting the network after 68  
   VTAM definition for Transport Manager Subsystem 69  
 remote terminal operator (RTO)  
   *See* RTO (remote terminal operator)  
 reports 234  
   IMS Monitor 234  
   MSC 234  
 reset attached process FM header 359  
 resource  
   commands to control MSC 229  
   resource (*continued*)  
     MSC (multiple systems coupling)  
       considerations 213  
       status classification 40  
       status recovery 39  
       status recovery mode 40  
   Resource Access Control Facility (RACF)  
     *See* RACF (Resource Access Control Facility)  
   Resource Manager (RM) 17  
   resource manager, definition 399  
   resource name uniqueness  
     disabling enforcement 18, 130  
   Resource Recovery Services/MVS (RRS/MVS)  
     *See* RRS/MVS (Resource Recovery Services/MVS)  
   resource structure 17  
     benefits 17  
   resource type consistency  
     disabling enforcement 19, 130  
   resources  
     IMSplex, in an  
       callable services 130  
       managing 129  
     name uniqueness 129  
     LTERM 131  
     user names 133  
     VTAM terminal node 132  
   TM  
     sharing 18  
   TM resources  
     MSNAME 131, 132  
     transactions 133  
     user IDs 134  
     user names 133  
     VTAM terminal nodes 132  
   type consistency 130  
 response mode  
   dynamic establishment 274  
   errors  
     ISC 319, 321  
   ISC  
     input 562  
   terminal  
     definition 447  
     design considerations 448, 537  
     effects of specifying  
       transaction-dependent 447  
     figure 447  
     introduction 36  
     methods of termination 448  
     restrictions 448  
     sizes of message queue data sets 479  
     sizes of workstation output buffers 479  
     station-by-station 447  
     when activated 447  
 response requests, output message 487  
 response requirements  
   IMS commands and indicators 470, 486  
   inquiry transactions  
     irrecoverable 321, 489  
     recoverable 321, 488  
   irrecoverable-inquiry transactions 67  
   response requirements (*continued*)  
     ISC messages 323  
     LU 6.2 application program 67  
     MFS control requests 490  
     output ISC messages 323  
     verifying IMS receipt 323, 489  
     VTAM indicators and commands 264, 470  
   response time 80, 237  
 restart  
   coding CICS applications 576  
   output available, ISC 307  
 restart and recovery 570  
 restart transaction, CICS 544  
 resynchronization, message  
   *See* message resynchronization  
 Return Destination Process Name  
   *See* RDPN  
 Return Primary Resource Name  
   *See* RPRN  
 RM affinity 41  
 RNR  
   *See* Rapid Network Reconnect  
 routing  
   messages  
     in an MSC-IMSplex  
       configuration 238  
   routing code, definition 19  
   routing exit routines  
     link routing 249  
     MSC (multiple systems coupling) conversations 216  
     MSC routing 247  
     program routing 249  
     terminal/input routing 248  
   Routing exit routines  
     Terminal Routing exit routine 248  
     TM/MSC Message Routing and Control Exit Routine 248, 249  
   routing messages  
     destination name 206  
     ISC examples 281  
     parameters 281  
     SYSIDs 206  
   routing path  
     MSC (multiple systems coupling) 201  
   RPRN (Return Primary Resource Name)  
     ATTACH FM header 380  
     message routing, ISC 281  
     SCHEDULER FM header 380  
   RQ\* messages, LUSTATUS command 343  
   RQD\* 263, 323, 328  
   RQE\* 263, 323, 328  
   RQR command, SLU P 440  
   RRS/MVS (Resource Recovery Services/MVS) 399  
     description 399  
     resource recovery with 399  
   RSHUT command 347  
   RSR (Remote Site Recovery)  
     protected conversations and 403  
     restarting the network 68  
     shared queues, planning for 118  
   RTO (remote terminal operator) 63  
   RTR (ready-to-receive) command 493

RTR (ready-to-receive) command  
*(continued)*  
 Fast Path 493  
 IMS functions 493  
 protocol 346  
 resetting component status to  
 unprotected 454  
 summary 346, 493  
 RU (request unit) chaining in ISC 339

## S

sample programs  
 using ISC between IMS and  
 CICS 593  
 SBI (stop bracket initiation)  
 command 355  
 CICS 556  
 IMS-CICS session 556  
 session shutdown 355  
 use in data flow control 253  
 SC (session control) protocols  
*See also* ISC, SC protocols  
 BIND parameters 310  
 binding sessions 302  
 negotiable versus nonnegotiable  
 BIND 303  
 parallel session 303  
 resolving a race 304  
 single session 303  
 synchronizing sessions 304  
 message resynchronization 304  
 commands used 304  
 designing procedures 305, 310  
 when required 304  
 session initiation 312  
 completing 312  
 ISC 301  
 session states 311  
 session termination 313  
 abnormal 314  
 normal 313  
 STSN flow 314  
 primary-to-secondary half  
 session 314  
 secondary-to-primary half  
 session 315  
 STSN format 317  
 XRF complex, establishing an ISC  
 session 302  
 XRF complex, establishing  
 connection 302  
 SCA (system control area), ISC  
 support 279  
 SCHEDULER FM header  
 ATTACH 360  
 chained message support 361  
 example 525  
 format 390  
 IMS-CICS session 567  
 introduction 360, 361  
 MFS 367  
 parameter description 378, 381  
 SCHEDULER FM headers  
 request for asynchronous  
 execution 272

scheduling  
 algorithm 29  
 AOI transactions 117  
 Fast Path messages 19  
 scratchpad area (SPA)  
*See* SPA  
 screen protection, Finance  
 Communication System  
 BID option 453  
 NOBID option 453  
 screens  
 protection 39  
 unprotected screen option 86  
 SCS (SNA character string) controls  
 format controls 523  
 function code assignments 524  
 SDF II, definition 81  
 SDT (start data traffic) command 312  
 completing session initiation 312  
 IMS 469  
 secondary logical unit  
 design considerations 266  
 first speaker in ISC 266  
 secondary logical unit type P  
*See* SLU P  
 security  
 APPC transactions 431  
 intermediate IMS  
 MSC 226  
 ISC 257  
 LTERM security for commands 46  
 LTERM security for transactions 45  
 MSC  
 intermediate IMS 226  
 MSC (Multiple Systems  
 Coupling) 225  
 SMU  
 LTERM security for  
 commands 46  
 LTERM security for  
 transactions 45  
 SMU and MSC 225  
 SMU in MSC 226  
 security considerations  
 CICS 562  
 Security Maintenance utility (DFSISMP0)  
 security for MSC (Multiple Systems  
 Coupling) 225  
 Security Maintenance Utility (DFSISMP0)  
 MSC (Multiple Systems  
 Coupling) 226  
 security options 44  
 APPC/IMS, RACF 47  
 APPC/IMS, SAF 47  
 command authorization 45  
 DFSCCMD0 Command  
 Authorization exit routine 46  
 user ID 45  
 ETO 47  
 user ID 47  
 user LTERM name 47  
 levels of security 44  
 access to resources 44  
 access to terminals 44  
 password 46  
 LTERM name 46  
 user ID 46

security options *(continued)*  
 RACF 44  
 security profile 45  
 DFSCTRNO Transaction  
 Authorization exit routine 45  
 user ID 45  
 signon verification 44  
 SMU 44  
 transaction authorization 45  
 RACF 45  
 SMU 45  
 transaction command 46  
 transaction security 431  
 RACF 431  
 UACC (NONE) 431  
 selective receiver ERP  
 description 347  
 sense codes 347  
 send and receive protocol  
 bracketing  
 input 478  
 output 485  
 IMS 473  
 SEND INVITE EXEC command,  
 CICS 540  
 SEND LAST EXEC command, CICS 541  
 send/receive and bracket protocol 473  
 SEND/RECEIVE EXEC command,  
 CICS 540  
 sender ERP, sense codes 351  
 sending IMS commands from CICS 561  
 sense code 353  
 definition 353  
 error  
*See* error handling  
 received during ISC 353  
 selective receiver ERP 347, 351  
 sender ERP 351, 353  
 sent during ISC 354  
 separating input and output devices 34  
 sequence numbers  
 description 309  
 maintaining 305  
 management 317, 466  
 storage 317  
 use 310, 466, 470  
 serial transactions  
 in an MSC network 221  
 processing  
 in a shared queues  
 environment 100  
 session 6  
 binding 302  
 definition 6  
 establishing 11  
 ISC, establishing 301  
 parallel 303  
 remote control 289  
 requirements to bind ISC 302  
 single 303  
 session initiation 66  
 bind parameters  
 Finance Communication  
 System 464  
 IMS-CICS 555  
 ISC 301  
 possible session states 311

- session initiation (*continued*)
  - requested by
    - CICS 555
    - master terminal operator, IMS 301, 464
    - network operator, z/OS VTAM 301, 464
    - system definition 301, 464
    - workstation 464, 478
  - step-by-step explanation 464
  - transmission sequence 464
  - ways to request 66
- session local flag, ATTACH FM header 381
- session parameters
  - establishing connection 301, 441
  - use 301, 441
- session termination 313
  - abnormal 314, 556
  - BID option specified, effects 492
  - CICS 556
  - conditional versus unconditional 266
  - definition 313, 470
  - immediate
    - definition 470, 556
    - master terminal operator, IMS 313, 470
    - network operator, z/OS VTAM 313, 470
    - station 313
    - workstation 470
  - normal 313, 556
  - orderly
    - definition 471
    - initiated 355, 471
    - requested by CICS 556
    - sequence 355, 471
    - summary (figure) 470
    - symmetrical (SBI/BIS) in ISC 355
- set-and-test-sequence-numbers (STSN) command
  - See* STSN command
- shared queues 12
  - APPC and OTMA messages processing MSC remote transactions 245
  - autologon terminal 99
  - benefits 13
  - cloned configuration 101
  - concepts 96
    - back-end IMS 96
    - Common Queue Server (CQS) 96
    - front-end IMS 96
    - queue types 97
    - when IMS registers and deregisters interest in transactions 97
  - configuring 101
  - conversational transactions concepts 100
  - CQS
    - execution parameters 106
    - global structure definition 106
    - initialization parameters 106
    - local structure definition 106
  - defining CFRM policy 103
  - example 105
- shared queues 12 (*continued*)
  - defining IMS control region execution parameters 106
  - definition 12
  - EMH queue option overview 20
  - enabling 103
  - environment 13
    - AOI transactions 117
    - APPC messages 115
    - components of, illustration 14
    - operating in, overview 12
    - OTMA messages 115
    - planning for 101
    - planning for MSC (multiple systems coupling) 117
    - required components of 13
  - fast path message queue list structures example 106
  - Fast Path message queue list structures
    - defining 105
  - link definitions in an IMSplex deleting 244
  - locking messages on queue concept 98
  - message flow concepts 98
  - message queue list structures defining 105
  - example 105
  - message routing in an MSC-IMSplex configuration 238
  - message switching
    - Output Creation exit routine (DFSINSX0) 99
  - MSC (Multiple Systems Coupling) coexistence 237
  - sharing MSNAME definitions and SYSIDs 240
  - MSC MSNAME definitions duplication 243
  - sharing MSNAME statements and SYSIDs 240
  - MSNAME definitions deleting 244
  - name uniqueness 129
  - partitioned configuration 102
  - planning for 95
  - pseudoabend U0830 avoiding 247
  - registering and deregistering interest in LTERMs concept 98
  - registering interest concept 97
  - registering interest in MSC (multiple systems coupling) resources concept 98
  - remote processing defined 97
  - serial transactions processing 100
  - SYSIDs
    - cloning MSC SYSIDs in an IMSplex 244
- shared queues 12 (*continued*)
  - SYSIDs (*continued*)
    - managing MSC SYSIDs in an IMSplex 244
    - sharing MSNAME definitions and SYSIDs 240
    - when an IMSplex and MSC network coexist 244
  - TM resources
    - managing 129
  - tuning performance 118
    - parameters 118
    - structures 118
  - undefined transactions
    - Output Creation exit routine (DFSINSX0) 99
  - z/OS log stream
    - defining 106
    - z/OS system log, role of 14
- sharing printers
  - between systems 92
  - between users 92
- shortcut keys keyboard xix
- shutdown
  - IMSplex, in an 135
- shutting down an IMS network 300, 472
- SIGNAL command
  - protocol 355
  - VTAM 494
- signing off 11
- signing off, definition 11
- signing on, definition 11
- signon and static terminals 62
- single session, ISC bind requirements (IMS-to-IMS) 289
- SINGLE1 parameter 278, 334
- SINGLE2 parameter 278, 334
- slave-master MSC (multiple systems coupling) relationship 198
- SLU P 435
  - application program
    - converting from Finance 438
    - functions available 437
    - MFS considerations 437
    - XRF considerations 438
  - bracket and send/receive protocols 443, 473
  - facilities 445
  - input component definition 446
  - MFS DPM option 481
  - network
    - major parts 436
  - sample configuration 436
  - SCAN/NOSCAN 438
  - session parameters 503
  - terminals supported 436
  - VTAM
    - commands and indicators 439
    - facilities 439
    - workstations 436
    - XRF complex, establishing connections 442
- small buffer devices 89
- SMU (Security Maintenance utility) ETO 9



- SMU (Security Maintenance utility)
  - (continued)
  - security for MSC (Multiple Systems Coupling) 225
- SNA (systems network architecture)
  - character string (SCS) controls
  - See SCS controls
- SNA commands
  - See VTAM, commands and indicators
- SNA QUIESCE 39
- SPA (scratchpad area) 30
  - characteristics 31
  - MSC (multiple systems coupling)
    - conversations 215
    - size 211, 215
    - transaction code field 31, 37
- splitting databases, MSC (multiple systems coupling) 214
- SPOOL command
  - output control 90
- spooled output control 90
- START command
  - starting a SLU P network 463
- start data traffic (SDT) command
  - See SDT (start data traffic) command
- start lists, VTAM 64
- START/RETRIEVE EXEC commands, CICS 544
- starting a SLU P network 65
- starting an IMS network 65
  - making IMS ready
    - /START command 300, 463
    - results 300, 463
  - prerequisites 65, 463
  - results 65
- starting workstations
  - See session initiation
- startup parameters 107
- station, user 436
  - See also workstation
  - definition of as logical unit 436
  - device selection 436
- Statistical Analysis Utility and MSC 233
- status
  - non-recoverable 40
  - recoverable 40
  - resource
    - classification 40
  - significant 40
    - command 40
    - end-user 40
- status recovery mode 40
  - GLOBAL 40
  - LOCAL 41
  - NONE 41
  - RCVYCONV= 41
  - RCVYFP= 42
  - RCVYSTSN= 41
  - resource types 41
- stop bracket initiation (SBI) command
  - IMS-CICS session 556
- stop bracket initiation command
  - See SBI (stop bracket initiation) command
- STOP command 38
- STOP state 38, 68
- stopped transactions in MSC 232
- stopping
  - MSC 227
  - workstations
    - See session termination
- structure
  - creation and deletion 143
  - list
    - definition 14
    - overflow, definition 14
    - primary, definition 14
    - pair, definition 14
- structure recovery data set (SRDS)
  - overview 14
- STSN command 314
  - action code 470
  - action code format 317, 319, 466
  - action required 310, 467
  - controller sequence number,
    - verification 467
  - Finance Communication Systems 466, 470
  - flow 314
  - message resynchronization 466, 469
  - response 310, 468
    - requirements 468, 469
    - response requirements 470
    - summary 469
    - summary (figure) 310
  - sync points 309
  - VTAM sequence number,
    - verification 467
- STSN function, requirements for ETO 191
- STSN support for ETO devices 192
- SUBPOOL macro 274, 294
- subpools users
  - dynamic allocation 274
  - VTAM 274
- subsystem
  - direct-control 557
  - external, definition 9
  - queued 557
- suspending output from IMS 470
- sync point
  - definition 29
  - input messages, ISC 322
  - ISC
    - CICS 562
    - input 326
    - output 327, 328
    - requirements 323
- synchronization point
  - definition 29
- synchronization, ISC half sessions 321
- synchronous processing
  - See also ATTACH FM header
  - ATTACH FM headers, ISC 358
  - CICS 539
  - definition 272
- syntax diagram
  - how to read xiii
- SYS1.VTAMLST 60
  - ATCCONxx member 64
  - ATCSTRyy member 64
  - defining IMS as an application node 60
  - VTAM nodes 61
- SYSID (system identifier) 204
- SYSID keyword, MSC (multiple systems coupling) 199
- SYSID tables
  - deleting MSNAME definitions in an IMSplex 244
- SYSIDs
  - cloning in an IMSplex 244
  - managing in an IMSplex 244
  - sharing among systems in an IMSplex 240
- SYSMSG FM header
  - format 391
- SYSMSG FM headers
  - ATTACH FM header 361
  - sending 361
  - types 362
- sysplex environment 12
  - APPC messages 115
    - asynchronous 115
    - synchronous 115
  - definition 12
  - eligibility for processing 114
  - messages 114
  - OTMA messages 115
    - asynchronous 115
    - synchronous 115
  - shared queues in 12
- SYSSTAT FM header, format 392
- system
  - definition
    - IMS ISC sample 291, 296
    - messages, length 362
  - system control area (SCA)
    - See SCA (system control area)
  - system definition 217
    - macros 217, 218
    - MSC
      - general considerations 217
      - implications 223
      - partner 218
      - verifying 224
    - MSC (multiple systems coupling)
      - exit routines 222
      - local 218
      - macros 218
      - setting link priorities 220
  - system identification for logical link paths 199
  - system identifier (SYSID) 204
  - system log 233, 236
  - system log, z/OS
    - shared queues and 14

## T

- terminal
  - autologon
    - shared queues 99
  - physical, defining 149
- TERMINAL macro 295
  - defining an ISC session 295
  - MODETBL= keyword 63
- terminal modes 36
  - conversation mode 37
  - exclusive 38
  - lock mode 38

- terminal modes (*continued*)
    - response mode 36
    - SNA QUIESCE 39
  - Terminal Reconnect Protocols 57
  - Terminal Routing exit routine 248
  - terminals
    - as a TM resource in a sysplex 132
    - attached through VTAM 24
    - Class 1 with XRF 26
    - Class 2 with XRF 26
    - COMPINOP state 39
    - component protection state 39
    - connections 25
    - conversation mode 37
    - definition 4
    - device class control 88
    - documenting requirements 24
    - ETO and exclusive mode 38
    - exclusive mode 38
    - IMSplex, in an 132
      - managing 129
    - INOP state 39
    - lock mode 38
    - logical
      - chains 33
      - master terminal 35
      - queues 33
      - relationship to physical terminals 32
    - LU 6.2 terminals and Fast Path 47
    - modes and states 36, 39
    - name uniqueness 129
    - nonswitched 25
      - contention, with 25
    - nonswitched communications network 34
    - page protection state 39
    - polled 25
    - profiles 59, 61
    - QERROR state 38
    - QLOCK state 38
    - response mode
      - See* response mode, terminal
    - RM definition 132
    - screen protection state 39
    - separating input and output devices 34
    - SNA QUIESCE 39
    - states 38
    - STOP state 38
    - support for, IMS 24
    - switched 25
    - sysplex, in a
      - recovery status 43
    - test mode 38
    - VTAM terminal nodes 132
  - terminating communications, MSC
    - conversations 217
  - terminating ISC Extension
    - conversations 321
  - termination, session
    - See* session termination
  - test mode 38, 271
  - TM resources 131
    - APPC Descriptors 131
    - LTERM (logical terminal) 131
    - MSNAME 132
  - TM resources (*continued*)
    - sharing 18
      - disabling sharing 18
    - transactions 133
      - user IDs 134
      - user names 133
      - VTAM terminal nodes 132
  - TM/MSC Message Routing and Control
    - Exit Routine 248, 249
  - traffic between two IMS systems 274
  - traffic report
    - MSC 234
  - TRANSACT macro
    - EDIT=ULC 87
    - PRTY= keyword 220
    - translation to uppercase 83
  - transaction 66
    - code, definition 19
    - codes, unique 28
    - MSC statistics 236
    - multiple systems 197
    - states 67
  - Transaction Analysis utility 233
  - transaction code (remote destination) 206
  - Transaction Manager
    - introduction 3
    - resources 131
      - APPC Descriptors 131
      - LTERM (logical terminal) 131
      - MSNAME 132
      - transactions 133
      - user IDs 134
      - user names 133
      - VTAM terminal nodes 132
  - Transaction Manager services 7
  - transaction sync point relationships 322, 562
  - transaction types
    - commands 490
    - definitions 66, 488
    - inquiry
      - definition 486
      - recoverable or irrecoverable 488, 489
    - ISC session, during 270
    - message switches
      - IMS 489
      - ISC 375
      - ISC examples 282, 285
    - supported by ISC, list 256
    - test mode, in ISC 271
    - update 488
  - transactions
    - abends 575
    - as a TM resource in a sysplex 133
    - conversational
      - in a shared-queues environment 100
    - requeuing suspended 117
    - serial
      - in a shared queues environment 100
    - undefined to inputting IMS
      - Output Creation exit routine (DFSINSX0) 99
  - transactions (*continued*)
    - when IMS registers and deregisters interest 97
  - transparency option 85
  - tuning
    - buffers 234
    - MSC (multiple systems coupling) environment 213
    - MSC tuning and monitoring 233
  - two-phase commit process,
    - definition 399
  - TYPE macro 25
- ## U
- Unaccessed ETO User Control
    - Blocks 182
  - UNBIND command, stopping session
    - initiation 312
  - unconditional bracket termination, IMS
    - error handling 490, 492
  - unit of recovery
    - definition 400
    - in-flight, definition 400
    - indoubt, definition 400
  - unit of work (UOW)
    - tracking
      - shared queues environment 99
  - UNITYTYPE keyword on TYPE macro 51
  - unprotected screen option 86
  - unscheduled reassignments, MSC 228
  - UOW (unit of work)
    - tracking
      - shared queues environment 99
  - user
    - IMSplex, in an
      - RM definition 134
    - sysplex, in a
      - recovery status 43
  - USER 270
  - user descriptor 143, 167
  - user ID
    - IMSplex, in an
      - recovery status 44
  - user IDs
    - as a TM resource in a sysplex 134
    - IMSplex, in an 134
      - name uniqueness 134
  - user names
    - as a TM resource in a sysplex 133
    - IMSplex, in an 133
      - name uniqueness 133
  - user workstation
    - See* workstation, user
  - bracket protocol 330
  - user workstation.
    - See also* workstation, user
  - API (application program interface)
    - CICS asynchronous 557
    - CICS synchronous 557
  - USSTAB option defined in VTAM 63
  - USTOPPED state 68

## V

### verification

- IMS terminal support 24
- remote destinations 211
- transaction definitions across systems 224

### vertical partitioning 197

### VGRS parameter

- specifying a generic resource name 123

### Virtual Telecommunications Access

#### Method (VTAM)

- See VTAM (Virtual Telecommunications Access Method)

### VLVB records 377

### VPACING= parameter 69

### VTAM

- as a TM resource in a sysplex 132
- MSC (multiple systems coupling) physical link type 197
- terminal nodes 132

### VTAM (Virtual Telecommunications Access Method)

- ACBNAME parameter 219
- APPL statement 219
- attached terminals 24
- BB indicator 277, 343
- BID command 330, 449
- binary synchronous communications (BSC) 24
- BIS command 355
  - LU 6.1 half sessions 355
  - use with CICS 556
- bracket protocol 443
  - CD (change direction) 443
  - Finance Communication System 443
  - SLU P 443
- bracket protocols 272
- buffering 69
- CANCEL command 338, 494
- CD indicator 277, 441
- CHASE command 339
- COMM macro 219
- commands and indicators 264, 440
- devices with MFS support 24
- EB indicator 277, 344
- establishing sessions 441
  - Finance Communication System 441
  - SLU P 441
- facilities 264
  - commands and indicators 264, 439
  - data transmission 264
  - Finance Communication System 439
  - IMS 439, 440
  - ISC 264
  - SLU P 439
  - used by ISC 537, 558
- generation 60
  - IMS as host subsystem 60
  - LOGON MODE identifiers 63
  - NCP buffer pool values 62
  - storage requirements 61
  - VTAM buffer pool values 61

### VTAM (Virtual Telecommunications Access Method) (continued)

#### generation (continued)

- VTAM configurations 64
- VTAM nodes 61
- half-duplex protocol, ISC 330
- IMS, relationship to 6
- macros 266
  - SEND 266
  - TERMSESS 266
- missing interrupt handler (MIH) 69
- MSC (multiple systems coupling) linking 197
- network role 5
- node as chosen name 25
- output buffers 62
- pacing 69
- parallel sessions 219
- RQR command 440, 494
- SBI command 355
  - LU 6.1 half sessions 355
  - use with CICS 556
- SDLC using VTAM 219
- SDT command 312
- SESSION parameter 219
- SIGNAL command 355, 494
- synchronous data link control (SDLC) 24
- Transport Manager Subsystem, definition for 69
- UNBIND command 312
- VTAM 232

## W

### work unit

- backed out 304, 570
- CICS 570
- committed 304, 570
- definition 304
- example 305
- pending, unilateral decisions 306
- status at session initiation 311

### workload distribution, MSC 214

### workstation, user

- API 265, 535
  - CICS asynchronous 536
  - CICS synchronous 536
- bracket protocol
  - input messages, ISC 330
  - output messages, ISC 333
- definition as logical unit 274
- logical unit definition 6
- terminology 274

### workstations

- See also station, user
- Finance Communication System 436
- SLU P 436

## X

### XRF (Extended Recovery Facility) 26

- Class 1 terminals 54
- Class 2 terminals 52
- Class 3 terminals 53
- class of service 53

### XRF (Extended Recovery Facility) (continued)

- definition 49
- establishing communication
  - Finance Communication System 442
  - ISC 302
  - SLU P 442
  - system takeover considerations 442
- local queue manager data sets 100
- master terminals 35
- recovery modes 42
- SLU P application program 438
- takeover considerations 442
  - Finance Communication System 442
  - SLU P 442
- terminal support 26, 53
- terminals in 50

## Z

### z/OS

- log stream
  - defining 106
- system log 14
- VTAM Generic Resource affinity 122
- Z2 field in message prefix 88







Program Number: 5655-J38

Printed in USA

SC18-7808-02



Spine information:



IMS

Administration Guide: Transaction Manager

Version 9